

Channel and Component Requirements for Fully Shielded 1000BASE-T1 and 2.5G/5G/10GBASE- T1 Link Segments

Version 1.1



Author & Company	See Contributing Members on Page 3
Title	Channel and Component Requirements for Fully Shielded 1000BASE-T1 and 2.5G/5G/10GBASE-T1 Link Segments
Version	1.1
Date	17 May 2024
Status	Public
Restriction Level	Public

This document contains electrical requirements and measurement specifications on fully shielded 1000BASE-T1, 2.5GBASE-T1, 5GBASE-T1 and 10GBASE-T1 channels and components. It shall be used as a standardized common scale for the evaluation of the RF properties for physical layer communication channels to enable Multi-Gigabit Ethernet technology in Automotive.

This specification is available at members.opensig.org. Please check this website to ensure you have the latest revision of this document.

Version Control of Document

Version	Author	Description	Date
1.1	Contributing Members	Maintenance update for corrections and for improved clarity: <ul style="list-style-type: none"> • 4.5, item 8: Clarity improvement • 3.2: Environmental conditions changed for consistency with related ISO standards • Table 17: 1G CIDM requirement changed for consistency with OA TC9 1000BASE-T1 STP specification • Table 23, Table 26: max. frequency for PSANEXT Loss, PSAFEXT Loss, PSAACRF changed to 4GHz for 2.5G and 5G for consistency with IEEE 802.3ch – related changes in Table 3, Table 4 and Table 8 • Figure 53, Figure 54: de-embedding plane moved for consistency • Table 20: relation symbol in LCTL requirements corrected • Figure 96: segment lengths corrected for consistency with channel budget analysis • Equation (3-4): missing comma inserted • Crosstalk parameter abbreviation changed consistently by adding the suffix “Loss” in the entire document, e.g., PSANEXT Loss 	2024-02-20
1.0	Contributing Members	Clean up for publication	2022-12-27
0.10	Contributing Members	Corrections	2022-11-30
0.9	Contributing Members	Corrections	2022-11-17
0.8	Contributing Members	Chapter 4.3 (De-embedding Software Check) and Chapter 5.1 (FERs) reworked, Section 4.4.2 (consistency check #2) inserted	2022-09-23
0.7	Contributing Members	New method for characterization of cable test fixtures (Chapter 5.2.5) and related clarifications and additions in Chapters 6.1.1 and 6.2.1	2022-07-21
0.6	Contributing Members	Connector RL requirements for 2.5G and 5G added, cable and cable assembly RL requirement changed, case differentiation (N=0, N=1) introduced to WCC RL requirements, requirements for 1G changed to be same as in [7], annex D removed, clarifications and corrections	2022-06-30
0.5	Contributing Members	Added de-embedding option for cable assemblies, communication channels and mated pairs, added LCTL for cables, updated requirements, disclaimer updated	2022-01-12
0.4	Contributing Members	Cable length definition added, de-embedding measurement setup and	2021-07-08

		requirements for cables added, TDR measurement for channels and Annex D removed, corrections and improvements	
0.3	Contributing Members	Speed grades added in tables in Chapter 5	2021-02-19
0.2	Contributing Members	Classes introduced, Annex C and D, cable measurement fixture requirements, all connector pictures updated, some limits proposed	2021-02-18
0.1	Contributing Members	First baseline draft	2020-09-10

Restriction Level History of Document

Version	Restriction Level	Description	Date
1.1	Public	Status and restriction changed to "Public"	2024-05-17
1.1	OPEN Alliance Members	Interim version	2024-04-04
1.1	OPEN Alliance TC9 Members	Draft version	2024-02-20
1.0	Public	Status and restriction level changed to "Public"	2023-03-08
1.0	OPEN Alliance Members	Interim version	2022-12-27
0.10	OPEN Alliance TC9 Members	Draft version	2022-11-30
0.9	OPEN Alliance TC9 Members	Draft version	2022-11-17
0.8	OPEN Alliance TC9 Members	Draft version	2022-09-23
0.7	OPEN Alliance TC9 Members	Draft version	2022-07-21
0.6	OPEN Alliance TC9 Members	Draft version	2022-06-30
0.5	OPEN Alliance TC9 Members	Draft version	2022-01-12
0.4	OPEN Alliance TC9 Members	Draft version	2021-07-06
0.3	OPEN Alliance TC9 Members	Draft version	2021-02-19
0.2	OPEN Alliance TC9 Members	Draft version	2021-02-18
0.1	OPEN Alliance TC9, Technical Members only	Draft version	2020-09-10

Contributing Members

OPEN Alliance TC9 Chair: Bert Bergner (TE Connectivity Germany GmbH)

OPEN Alliance TC9 Vice Chair: Thomas Müller (Rosenberger Hochfrequenztechnik GmbH & Co. KG)

Contributors (in alphabetical order):

Bert Bergner (TE Connectivity Germany GmbH)

Matthias Bude (Amphenol / KE Elektronik GmbH)

Dominik Dorner (LEONI Kabel GmbH)

Terry Little (Foxconn Interconnect Technology)

Thomas Müller (Rosenberger Hochfrequenztechnik GmbH & Co. KG)

Harsh Patel (Amphenol CS)

Jörn Pfeifer (Rohde & Schwarz Vertriebs-GmbH)

Vimalli Raman (Yazaki Systems Technologies GmbH)

Michael Rucks (Aptiv Services Deutschland GmbH)

Junichi Takeuchi (Japan Aviation Electronics Industry Inc.)

Koji Wada (J.S.T. Mfg. Co. Ltd.)

Restriction Level: Public

Contents

Foreword (Disclaimer)	6
Introduction	10
Abbreviation/Symbols	11
1 Scope.....	13
2 Normative References	14
3 Terms and Definitions	15
3.1 Definition of Speed Grades	15
3.2 Environmental Conditions	15
3.3 Standalone Communication Channel (SCC)	15
3.4 Environment System (ES).....	16
3.5 Whole Communication Channel (WCC).....	16
3.6 Types of Connectors.....	17
3.7 Cable Assembly and Cable Length	17
3.8 Definition of RF Parameters.....	18
3.9 ISO and IEC Terminology.....	20
4 General Setup and Settings.....	21
4.1 Required Measurement Instruments	21
4.2 Vector Network Analyzer Settings and Calibration	23
4.3 De-embedding Software Check (informative)	28
4.4 De-embedding Measurement Results Consistency Tests.....	29
4.4.1 De-embedding Consistency Test #1: Self-de-embedding of 2X-Thru	29
4.4.2 De-embedding Consistency Test #2: TDR Comparison of Fixture Model to FIX-DUT-FIX.....	31
4.5 Handling Instructions	32
4.6 Presentation of Measurement Results	33
5 Measurement Fixtures and Terminations.....	34
5.1 Measurement Fixture Requirements for De-Embedding	34
5.2 Measurement Fixture Requirements for Direct Measurement.....	34
5.2.1 General Measurement.....	34
5.2.2 Connectors	37
5.2.3 PCB Connectors.....	38
5.2.4 Multiport PCB Connectors	40
5.2.5 Cables	41
5.3 Terminations for Triaxial Measurements.....	44
5.4 MDI Test Heads.....	47
6 Measurement Setups.....	49

6.1	Measurement Setups for Connectors.....	49
6.1.1	Single Port and Multiport Connectors for SCC.....	49
6.1.2	Connector Setups for ES - Crosstalk.....	53
6.1.3	Connector Setups for ES – Coupling and Screening Attenuation	54
6.2	Measurement Setups for Cables.....	58
6.2.1	Cable Setup for SCC.....	58
6.2.2	Cable Setup for ES – Coupling and Screening Attenuation	60
6.3	Measurement Setups for Cable Assemblies and Channels.....	61
6.3.1	General Remarks on Cable Assembly and Channel Measurements	61
6.3.2	Cable Assembly and Channel Setups for SCC.....	61
6.3.3	Cable Assembly Setup for ES – Coupling and Screening Attenuation	62
6.3.4	Whole Communication Channel Setup for ES – Crosstalk	63
6.3.5	Whole Communication Channel Setup for ES – Coupling and Screening Attenuation	65
7	Electrical Requirements	67
7.1	Requirements for Standalone Communication Channel	67
7.1.1	Requirements for Connectors in Context of SCC	67
7.1.2	Requirements for Cables in Context of SCC.....	70
7.1.3	Requirements for Cable Assemblies in Context of SCC.....	74
7.1.4	Requirements for Whole Communication Channel in Context of SCC	76
7.2	Requirements for Alien Coupling within Environment System	79
7.2.1	Requirements for Connectors in Context of ES	79
7.2.2	Requirements for Cables in Context of ES	83
7.2.3	Requirements for Cable Assemblies in Context of ES.....	85
7.2.4	Requirements for Whole Communication Channel in Context of ES	87
	Annex A (informative) Additional Measurement Setup Definitions.....	91
A.1	Measurement Fixture Examples	91
A.2	Coupling and Screening Attenuation Measurement Examples	92
	Annex B (informative) Reference Test Object Definitions.....	95
B.1	Reference Cable Assemblies	95
B.2	Reference Communication Channels.....	95
B.3	Reference Wiring Harness	96
	Annex C (informative) Measurement Setup for Detailed Cable Assembly Analysis.....	98

Foreword (Disclaimer)

OPEN Alliance Specification Copyright Notice and Disclaimer

A. OPEN Specification Ownership and Usage Rights

As between OPEN Alliance and OPEN Alliance Members whose contributions were incorporated in this OPEN Specification (the “Contributing Members”), the Contributing Members own the worldwide copyrights in and to their given contributions. Other than the Contributing Members’ contributions, OPEN Alliance owns the worldwide copyrights in and to compilation of those contributions forming this OPEN Specification. For OPEN Alliance Members (as that term is defined in the OPEN Alliance Bylaws), OPEN Alliance permits the use of this OPEN Specification on the terms in the OPEN Alliance Intellectual Property Rights Policy and the additional applicable terms below. For non-members of OPEN Alliance, OPEN Alliance permits the use of this OPEN Specification on the terms in the OPEN Alliance Specification License Agreement (available here: <http://www.opensig.org/Automotive-Ethernet-Specifications/>) and the additional applicable terms below. The usage permissions referenced and described here relate only to this OPEN Specification and do not include or cover a right to use any specification published elsewhere and referred to in this OPEN Specification. By using this OPEN Specification, you hereby agree to the following terms and usage restrictions:

A.i. Rights and Usage Restrictions Specific to OPEN Alliance Members

FOR OPEN ALLIANCE MEMBERS ONLY: In addition to the usage terms and restrictions granted to Members in the OPEN Alliance Intellectual Property Rights Policy, Members’ use of this OPEN Specification is subject this Copyright Notice and Disclaimer. Members of OPEN Alliance have the right to use this OPEN Specification solely (i) during the term of a Member’s membership in OPEN Alliance and subject to the Member’s continued membership in good standing in OPEN Alliance; (ii) subject to the Member’s continued compliance with the OPEN Alliance governance documents, Intellectual Property Rights Policy, and the applicable OPEN Alliance Promoter or Adopter Agreement, as applicable; and (iii) for internal business purposes and solely to use the OPEN Specification for implementation of this OPEN Specification in the Member’s products and services, but only so long as Member does not distribute, publish, display, or transfer this OPEN Specification to any third party, except as expressly set forth in Section 11 of the OPEN Alliance Intellectual Property Rights Policy. Except and only to the extent required to use this OPEN Specification internally for implementation of this OPEN Specification in Member’s products and services, Member shall not modify, alter, combine, delete portions of, prepare derivative works of, or create derivative works based upon this OPEN Specification. If Member creates any modifications, alterations, or other derivative works of this OPEN Specification as permitted to use the same internally for implementation of this OPEN Specification in Member’s products and services, all such modifications, alterations, or other derivative works shall be deemed part of, and licensed to such Member under the same restrictions as, this OPEN Specification. For the avoidance of doubt, Member shall not include all or any portion of this OPEN Specification in any other technical specification or technical material, product manual, marketing material, or any other material without OPEN Alliance’s prior written consent. All rights not expressly granted to Member in the OPEN Alliance Intellectual Property Rights Policy are reserved;

A.ii. Rights and Usage Restrictions Specific to Non-members of OPEN Alliance

FOR NON-MEMBERS OF OPEN ALLIANCE ONLY: Use of this OPEN Specification by anyone who is not a Member in good standing of OPEN Alliance is subject to your agreement to the OPEN Alliance Specification License Agreement (available here: <http://www.opensig.org/Automotive-Ethernet-Specifications/>) and the additional terms in this Copyright Notice and Disclaimer. Non-members have the right to use this OPEN Specification solely (i) subject to the non-member's continued compliance with the OPEN Alliance Specification License Agreement; and (ii) for internal business purposes and solely to use the OPEN Specification for implementation of this OPEN Specification in the non-member's products and services, but only so long as non-member does not distribute, publish, display, or transfer this OPEN Specification to any third party, unless and only to the extent expressly set forth in the OPEN Alliance Specification License Agreement. Except and only to the extent required to use this OPEN Specification internally for implementation of this OPEN Specification in non-member's products and services, non-member shall not modify, alter, combine, delete portions of, prepare derivative works of, or create derivative works based upon this OPEN Specification. If non-member creates any modifications, alterations, or other derivative works of this OPEN Specification as permitted to use the same internally for implementation of this OPEN Specification in non-member's products and services, all such modifications, alterations, or other derivative works shall be deemed part of, and licensed to such non-member under the same restrictions as, this OPEN Specification. For the avoidance of doubt, non-member shall not include all or any portion of this OPEN Specification in any other technical specification or technical material, product manual, marketing material, or any other material without OPEN Alliance's prior written consent. All rights not expressly granted to non-member in the OPEN Alliance Specification License Agreement are reserved.

B. Terms Applicable to both Members and Non-members of OPEN Alliance

B.i. Patents, Trademarks, and other Rights:

OPEN Alliance has received no Patent Disclosure and Licensing Statements related to this OPEN Specification. Therefore, this OPEN Specification contains no specific disclaimer related to third parties that may require a patent license for their Essential Claims. Having said that, the receipt of this OPEN Specification shall not operate as an assignment of or license under any patent, industrial design, trademark, or other rights as may subsist in or be contained in or reproduced in this OPEN Specification; and the implementation of this OPEN Specification could require such a patent license from a third party. You may not use any OPEN Alliance trademarks or logos without OPEN Alliance's prior written consent.

B.ii. Disclaimers and Limitations of Liability:

THIS OPEN SPECIFICATION IS PROVIDED ON AN "AS IS" BASIS, AND ALL REPRESENTATIONS, WARRANTIES, AND GUARANTEES, EITHER EXPLICIT, IMPLIED, STATUTORY, OR OTHERWISE, ARE EXCLUDED AND DISCLAIMED UNLESS (AND THEN ONLY TO THE EXTENT THEY ARE) MANDATORY UNDER LAW. ACCORDINGLY, OPEN ALLIANCE AND THE CONTRIBUTING MEMBERS MAKE NO REPRESENTATIONS OR WARRANTIES OR GUARANTEES WITH REGARD TO THIS OPEN SPECIFICATION OR THE INFORMATION (INCLUDING ANY SOFTWARE) CONTAINED HEREIN. OPEN ALLIANCE AND ALL CONTRIBUTING MEMBERS HEREBY EXPRESSLY DISCLAIM ANY AND ALL SUCH EXPRESS, IMPLIED, STATUTORY, AND ALL OTHER REPRESENTATIONS, WARRANTIES, AND GUARANTEES, INCLUDING WITHOUT LIMITATION ANY AND ALL WARRANTIES OF MERCHANTABILITY, FITNESS FOR A PARTICULAR PURPOSE OR USE, TITLE, NON-INFRINGEMENT OF OR ABSENCE OF THIRD PARTY RIGHTS, AND/OR VALIDITY OF RIGHTS IN THIS OPEN SPECIFICATION;

AND OPEN ALLIANCE AND THE CONTRIBUTING MEMBERS MAKE NO REPRESENTATIONS AS TO THE ACCURACY OR COMPLETENESS OF THIS OPEN SPECIFICATION OR ANY INFORMATION CONTAINED HEREIN. WITHOUT LIMITING THE FOREGOING, OPEN ALLIANCE AND/OR CONTRIBUTING MEMBERS HAS(VE) NO OBLIGATION WHATSOEVER TO INDEMNIFY OR DEFEND YOU AGAINST CLAIMS RELATED TO INFRINGEMENT OR MISAPPROPRIATION OF INTELLECTUAL PROPERTY RIGHTS.

OPEN ALLIANCE AND CONTRIBUTING MEMBERS ARE NOT, AND SHALL NOT BE, LIABLE FOR ANY LOSSES, COSTS, EXPENSES, OR DAMAGES OF ANY KIND WHATSOEVER (INCLUDING WITHOUT LIMITATION DIRECT, INDIRECT, SPECIAL, INCIDENTAL, CONSEQUENTIAL, PUNITIVE, AND/OR EXEMPLARY DAMAGES) ARISING IN ANY WAY OUT OF USE OR RELIANCE UPON THIS OPEN SPECIFICATION OR ANY INFORMATION HEREIN. NOTHING IN THIS DOCUMENT OPERATES TO LIMIT OR EXCLUDE ANY LIABILITY FOR FRAUD OR ANY OTHER LIABILITY WHICH IS NOT PERMITTED TO BE EXCLUDED OR LIMITED BY OPERATION OF LAW.

B.iii. Compliance with Laws and Regulations:

NOTHING IN THIS DOCUMENT OBLIGATES OPEN ALLIANCE OR CONTRIBUTING MEMBERS TO PROVIDE YOU WITH SUPPORT FOR, OR RELATED TO, THIS OPEN SPECIFICATION OR ANY IMPLEMENTED PRODUCTS OR SERVICES. NOTHING IN THIS OPEN SPECIFICATION CREATES ANY WARRANTIES OR GUARANTEES, EITHER EXPRESS OR IMPLIED, STATUTORY OR OTHERWISE, REGARDING ANY LAW OR REGULATION. OPEN ALLIANCE AND CONTRIBUTING MEMBERS EXPRESSLY DISCLAIM ALL LIABILITY, INCLUDING WITHOUT LIMITATION, LIABILITY FOR NONCOMPLIANCE WITH LAWS, RELATING TO USE OF THE OPEN SPECIFICATION OR INFORMATION CONTAINED HEREIN. YOU ARE SOLELY RESPONSIBLE FOR THE COMPLIANCE OF IMPLEMENTED PRODUCTS AND SERVICES WITH ANY SUCH LAWS AND REGULATIONS, AND FOR OBTAINING ANY AND ALL REQUIRED AUTHORIZATIONS, PERMITS, AND/OR LICENSES FOR IMPLEMENTED PRODUCTS AND SERVICES RELATED TO SUCH LAWS AND REGULATIONS WITHIN THE APPLICABLE JURISDICTIONS.

IF YOU INTEND TO USE THIS OPEN SPECIFICATION, YOU SHOULD CONSULT ALL APPLICABLE LAWS AND REGULATIONS. COMPLIANCE WITH THE PROVISIONS OF THIS OPEN SPECIFICATION DOES NOT CONSTITUTE COMPLIANCE TO ANY APPLICABLE LEGAL OR REGULATORY REQUIREMENTS. IMPLEMENTERS OF THIS OPEN SPECIFICATION ARE SOLELY RESPONSIBLE FOR OBSERVING AND COMPLYING WITH THE APPLICABLE LEGAL AND REGULATORY REQUIREMENTS. WITHOUT LIMITING THE FOREGOING, YOU SHALL NOT USE, RELEASE, TRANSFER, IMPORT, EXPORT, AND/OR RE-EXPORT THIS OPEN SPECIFICATION OR ANY INFORMATION CONTAINED HEREIN IN ANY MANNER PROHIBITED UNDER ANY APPLICABLE LAWS AND/OR REGULATIONS, INCLUDING WITHOUT LIMITATION U.S. EXPORT CONTROL LAWS.

B.iv. Automotive Applications Only:

Without limiting the foregoing disclaimers or limitations of liability in any way, this OPEN Specification was developed for automotive applications only. This OPEN Specification has neither been developed, nor tested for, non-automotive applications.

B.v. Right to Withdraw or Modify:

OPEN Alliance reserves the right to (but is not obligated to) withdraw, modify, or replace this OPEN Specification at any time, without notice.

© 2024 OPEN Alliance. This document also contains contents, the copyrights of which are owned by third parties who are OPEN Alliance Contributing Members. Unauthorized Use Strictly Prohibited. All Rights Reserved.

Introduction

The specification describes shielded link segments and their components for use in 1000BASE-T1 and 2.5G/5G/10GBASE-T1 Automotive Ethernet applications.

The specification defines measurement setups, test methodology, measurement fixtures and electrical requirements for measuring signal integrity parameters, crosstalk and shielding of connector and cable components as well as for cable assemblies and harnesses.

Abbreviation/Symbols

AACRF	Alien attenuation to crosstalk ratio – far end
a_c	Coupling attenuation
AFEXT Loss	Alien far end crosstalk loss
ANEXT Loss	Alien near end crosstalk loss
a_s	Screening attenuation
AUT	Area under test
CIDM	Characteristic impedance differential mode
c_0	Speed of light in vacuum
DC	Direct current
DUT	Device under test
ECU	Electronic control unit
EMC	Electromagnetic compatibility
ES	Environment system
FER	Fixture electrical requirement
FIX	Measurement fixture
IEC	International Electrotechnical Commission
IEEE	Institute of Electrical and Electronics Engineers
ISO	International Organization for Standardization
IL	Insertion loss
L	Cable length
L_A	Cable assembly length
LCL	Longitudinal conversion loss
LCTL	Longitudinal conversion transfer loss
MDI	Media dependent interface
OEM	Original equipment manufacturer
PCB	Printed circuit board
PHY	Physical layer transceiver
PSAACRF	Power sum attenuation to alien crosstalk ratio – far end

PSAFEXT Loss	Power sum alien far end crosstalk loss
PSANEXT Loss	Power sum alien near end crosstalk loss
RCA	Reference cable assembly
RCC	Reference communication channel
RWH	Reference wiring harness
RF	Radio frequency
RL	Return loss
S-parameter	Scattering parameter
SCC	Standalone communication channel
SDP	Shielded differential pair
SPP	Shielded parallel pair
STP	Shielded twisted pair
STQ	Shielded twisted quad
TCL	Transverse conversion loss
TCTL	Transverse conversion transfer loss
TDR	Time domain reflectometry
tr	Rise time
VNA	Vector network analyzer
WCC	Whole communication channel
Z_1	Common mode impedance of a shielded pair cable

1 Scope

The intention of this specification is to present the general RF requirements and test methodologies for physical layer communication channel and its components according to Figure 1 to enable 2.5/5/10GBASE-T1 technology using fully shielded cables and connectors for Automotive Ethernet applications. The requirements and test methods are described additionally for 1000BASE-T1 applications on fully shielded cabling to allow backward compatibility of components to class 2 requirements in [7]. This provides the possibility to qualify components, cable assemblies and channels for any of the speed grades defined in Chapter 3.1 with only one set of test groups. A single measurement result can be compared to the requirements of a multiple number of speed grades if the maximum frequency settings correspond to the fastest speed grade. The requirements for class 2 in [7] and for speed grade 1G in this document are the same. Thus, re-qualifications of 1G components, cable assemblies and channels are not necessary. Unshielded and shielded class 1 channels and components for 1000BASE-T1 are not in scope of this document since these topics are covered in [8] and [7] respectively.

These requirements are related to signal integrity and EMC behavior of the communication channel. The link segment requirements for 1000BASE-T1 according to [1] apart from mode conversion requirements and 2.5G/5G/10GBASE-T1 according [2] shall be met. The fully shielded differential cable is not limited to a specific construction, as no specific mechanical requirements are defined. Common types of shielded differential cables are STP, SDP, SPP, STQ, twin-axial cables or others.

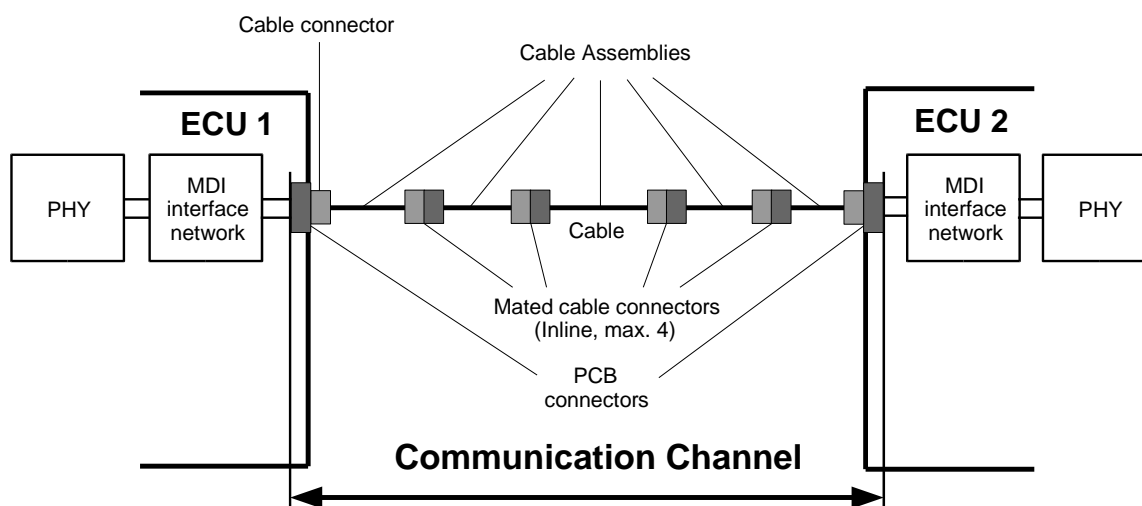

Figure 1: Definition of communication channel

The qualification of shielded cabling systems and components shall be done under well-defined setup to make results comparable. This document defines electrical parameters to be tested for the complete communication channel between two Ethernet nodes, for cable assemblies and cables and connectors as a single component of this communication channel. It contains test procedures, measurement setups and electrical requirements and shall be used as a standardized common scale for the evaluation of complete channels, cable assemblies and cables and connectors.

Electrical requirements on the communication channel are also stated in [1] and [2]. Other functional requirements such as mechanical and climatic stress as well as application dependent EMC relevant parameters may also be required but would be specified by the customer (OEM) and are not the focus of this document.

2 Normative References

The following references contain relevant content for the requirements that are defined within this document. For dated references, only the edition cited applies. For undated references, the latest edition of the referenced document (including any amendments) applies.

- [1] IEEE Std 802.3bp™: 2016, *Standard for Ethernet Amendment 4: Physical Layer Specification and Management Parameters for 1 Gb/s Operation over a Single Twisted Pair Copper Cable*
- [2] IEEE P802.3ch™: 2020, *Standard for Ethernet Amendment: Physical Layer Specifications and Management Parameters for 2.5 Gb/s, 5 Gb/s, and 10 Gb/s Automotive Electrical Ethernet*
- [3] DIN EN 61935-1: 2010, *Specification for the testing of balanced and coaxial information technology cabling – Part 1: Installed balanced cabling as specified in the standards series EN 50173 (IEC 61935-1:2009, modified)*
- [4] DIN EN 50289-1-7: 2001, *Communication cables – Specifications for test methods – Part 1-7: Electrical test methods; Velocity of propagation*
- [5] IEC 62153-4-7: 2015, *Metallic communication cable test methods – Part 4-7: Electromagnetic compatibility (EMC) – Test method for measuring of transfer impedance Z_T and screening attenuation a_s or coupling attenuation a_c of connectors and assemblies up to and above 3 GHz – Triaxial tube in tube method*
- [6] IEC 62153-4-9: 2018, *Metallic communication cable test methods – Part 4-9: Electromagnetic compatibility (EMC) – Coupling attenuation of screened balanced cables, triaxial method*
- [7] OPEN Alliance TC9, *Channel and Components Requirements for 1000BASE-T1 Link Segment Type A (STP)*
- [8] OPEN Alliance TC9, *Channel and Components Requirements for 1000BASE-T1 Link Segment Type A (UTP)*
- [9] IEEE Std 370™: 2020, *Standard for Electrical Characterization of Printed Circuit Board and Related Interconnects at Frequencies up to 50 GHz*
- [10] IBIS Open Forum, *Touchstone® File Format Specification*
- [11] OPEN Alliance TC8, *Automotive Ethernet ECU Test Specification*
- [12] OPEN Alliance TC8, *Automotive Ethernet ECU Test Specification Layer 1*
- [13] OPEN Alliance TC12, *IEEE 1000BASE-T1 Physical Media Attachment Test Suite*

3 Terms and Definitions

3.1 Definition of Speed Grades

This specification covers 1000BASE-T1 class 2 and 2.5G/5G/10GBASE-T1 channels and components within a single document. To distinguish between the data rates the following naming convention referred to as speed grades are defined (Table 1).

Table 1: Definition of speed grades

Physical layer specification	Speed grade
1000BASE-T1 (class 2 acc. to [7])	1G
2.5GBASE-T1	2.5G
5GBASE-T1	5G
10GBASE-T1	10G

3.2 Environmental Conditions

The electrical requirements in Chapter 7 for communication channels, cable assemblies, cables and connectors shall be met for all operating conditions of the application. Within the scope of this document, measurements are carried out at a temperature of (23 ± 5) °C and a relative humidity of (50 ± 25) %. The atmospheric pressure shall be equivalent to altitudes between sea level and 2000 m above. Measurements at other environmental conditions are outside the scope of this document.

It is recommended to keep the temperature constant during the measurements with a tolerance of ± 1 °C to ensure sufficient stability of test equipment calibration. The equipment including optional electronic calibration devices shall be switched on some time before calibration and measurements according to the recommendations of the equipment manufacturers to allow temperature accommodation of the devices.

3.3 Standalone Communication Channel (SCC)

The SCC consists of two PCB connectors, cable and up to four inline connectors. PCB and inline connectors can be single or multiport type. Multiport means that the connector provides more than one differential port. Hybrid multiport connectors additionally can have single pins to connect single ended data signals or power supply lines.

The maximum allowed insertion loss and propagation delay time for SCCs is independent from the SCC length and shall not exceed the requirements in Table 22 (see [1] and [2]). The achievable SCC length depends on the insertion loss and propagation delay time of the components, i.e. cables and connectors, that are used. The component requirements in Chapters 7.1.1 and 7.1.2 are defined to allow a length up to at least 15 m with up to 4 inline connectors if all cable assemblies in the SCC use low loss case cables according to Table 20. Use of standard loss case cables according to Table 20 allows SCC lengths up to at least 10 m.

The return loss requirement definitions in [2] allow a relaxation for 5G and 10G link segments if the insertion loss is lower than 15 dB at key frequencies of 1.5 GHz or 3 GHz respectively. This is typically the case for

shorter link segments. Table 22 considers this definition by differentiation between short SCC and long SCC case.

3.4 Environment System (ES)

The ES consists of power and signal cables that may also include other application than 1G/2.5G/5G/10G Ethernet within the same wiring harness.

3.5 Whole Communication Channel (WCC)

The WCC is the complete electrical wired connection, i.e. the wiring harness, between two ECUs with Ethernet interfaces as shown in Figure 2. In contrast to the link segment definitions in [1] and [2], PCB end connectors belong to the communication channel.

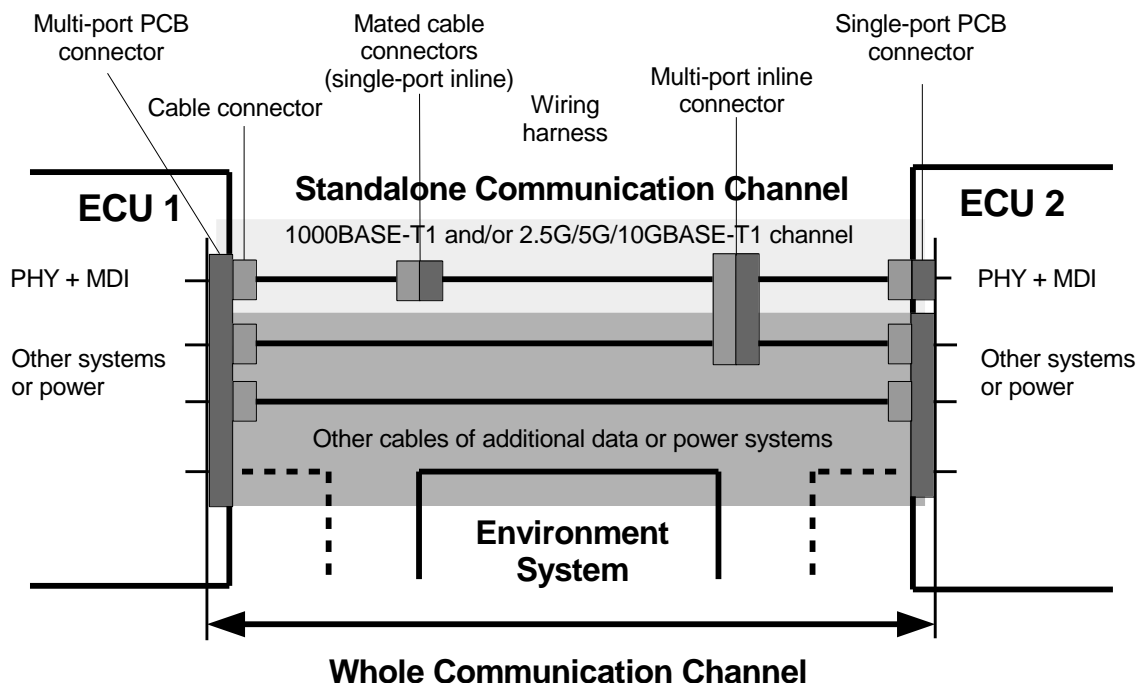

Figure 2: Whole communication channel and its components

A WCC consists of the standalone communication channel that is used for the 1G/2.5G/5G/10G Ethernet data transmission between the ECUs and an additional environment system for data or power transmission. This model is used to consider the electromagnetic interaction between the Ethernet and other systems that can occur as crosstalk within multiport connectors, multi-pair cables or bundles of cables. Although the scope of this document is on 1G/2.5G/5G/10G only, specific applications may require the characterization of crosstalk parameters between Ethernet channels and other data channels in the same component or system. Examples include multiport connectors with coaxial or UTP ports for other data applications in proximity to Ethernet ports. If no specific requirements are defined by these other applications, the recommendations for 1G/2.5G/5G/10G on multiport measurement fixtures, related measurement methods and crosstalk requirements may be applied. Further signal integrity and EMC parameters for data channels other than 1G/2.5G/5G/10G are not within the scope of this specification. Power and other multi-purpose contacts and cables are also not covered by this specification.

The WCC, SCC and ES that are measured shall be manufactured as close as possible to the real application as installed within the vehicle. As usually there is a large diversity of wiring harnesses among an OEM, the DUT can be a simplified generic representation of the complete wiring harness in collaboration with the involved departments. To allow comparing the electrical properties of components from different suppliers and comparing the measurement results of different test houses, Annex B shows reference test objects for cable assemblies, communication channels and wiring harnesses.

The requirements on connectors and cables as components have been derived from the reference communication channel RCC4 as in Figure 96 of Annex B.2. This topology represents a short camera pigtail followed by longer cable sections as challenging but realistic scenario in terms of return loss. The minimum length of the first cable assembly shall be at least 0.25 m and the minimum length of the second cable assembly shall be at least 1 m from each side of the link segment to meet the link segment RL requirements with a high probability based on the defined cable and connector requirements. Combinations of shorter cable assemblies are allowed if the whole link segment meets the WCC SCC requirements.

3.6 Types of Connectors

Connectors may be single port or multiport types if they consist of more than one port in a common housing. Connectors may be cable and PCB connector types. Cable connectors are assembled on a cable. PCB connectors are assembled on a PCB. A connector typically is socket or plug type. Annex A.1 gives examples of the different connector types. Figure 3 defines the port numbering for a multiport connector, corresponding to the S-parameter port numbering in Table 2.

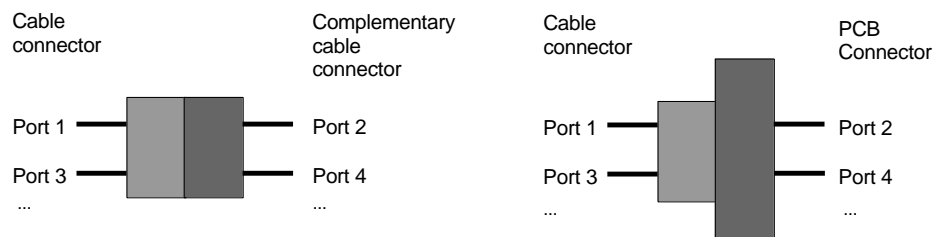

Figure 3: Typical definition of S-parameter ports for multiport cable and PCB connectors

3.7 Cable Assembly and Cable Length

A cable assembly consists of a single cable segment with a cable connector attached on each end as shown in Figure 4. Cable connectors can be socket or plug as described in 3.6. The length of the cable assembly depends on the specific application. Annex B.1 defines a reference cable assembly RCA1, which can be used as common basis and if an application specific definition is not available.

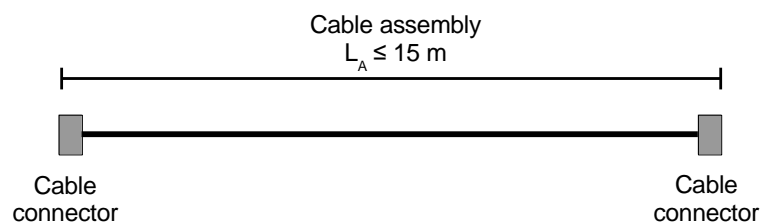

Figure 4: Definition of cable assemblies

While the total cable assembly length L_A is measured between the connectors mating faces, cable length L shall be measured as the length where the cable geometry is unaffected by the termination, e.g. by potential cable squeezing in the crimp zones or other mechanical devices such as sealings and cable ties. This is typically the cable length between the points where the cable comes out of the cable crimp ferrules. These locations can be inside or outside the connector housing depending on the connector design. This definition ensures consistency of the measurement setups independent from individual connector styles and dimensions. Figure 5 shows how the cable length L and cable assembly length L_A are measured.

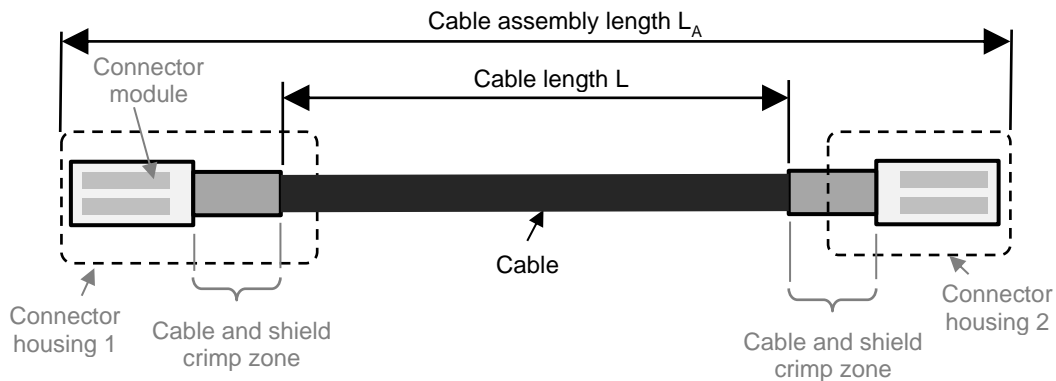

Figure 5: Cable length definition for cable assemblies

3.8 Definition of RF Parameters

For all parts of the communication channel, the RF requirements are defined in terms of the following RF and S-parameters:

Table 2: Definitions for RF and S-parameters

Test parameter	Symbol or related S-parameter	Description
Impedance		
CIDM	Z_{RF}	Characteristic impedance differential mode (TDR measurement)
Single channel characteristics (e.g. Port 1,2)		
Propagation Delay	t_d	Propagation delay, i.e. phase delay according to [4], see equation (3-5)
RL	S_{dd11}, S_{dd22}	Return loss
IL	S_{dd21}^1	Insertion loss
LCL ²	S_{dc11}, S_{dc22}	Longitudinal conversion loss
LCTL ²	S_{dc12}, S_{dc21}	Longitudinal conversion transfer loss
Crosstalk to neighbor ports on multiport connectors		
ANEXT Loss	S_{dd31}, S_{ddyx}	Alien near end crosstalk loss

¹ Connectors and cabling hardware are considered passive and reciprocal systems with $S_{dd21} = S_{dd12}$. Thus, insertion loss can be derived from either of these two parameters. This document only refers to S_{dd21} regarding insertion loss for the sake of clarity.

² For compliance to the specification measurements of LCL and LCTL are sufficient as LCL and TCL are considered reciprocal and LCTL and TCTL are considered reciprocal (see [1]). The reciprocal parameters TCL and TCTL can be measured instead of LCL and LCTL.

AFEXT Loss	S_{dd41}, S_{ddyx}	Alien far end crosstalk loss
PSANEXT Loss	see equation (3-1)	Power sum alien near end crosstalk loss
PSAFEXT Loss	see equation (3-2)	Power sum alien far end crosstalk loss
PSAACRF	see equation (3-3)	Power sum attenuation to alien crosstalk loss ratio far end
Single channel characteristics (e.g. Port 1,2)		
Coupling Attenuation	a_c , see equation (3-6)	Coupling attenuation
Screening Attenuation	a_s , see equation (3-7)	Screening attenuation

The following equations can be used to calculate the power sum crosstalk of connectors.

PSANEXT Loss for a disturbed signal N can be calculated for every port by means of the following equation:

$$PSANEXT Loss (f)_N = -10 \log_{10} \sum_{j=1}^m 10^{\frac{-ANEXT Loss (f)_{N,j}}{10}} dB \tag{3-1}$$

where the function $ANEXT Loss (f)_{N,j}$ represents the magnitude (in dB) of the ANEXT Loss at frequency f of the disturbing signal j (1 to m of the relevant disturbing neighbor signals) for the disturbed signal N .

PSAFEXT Loss for a disturbed signal N can be calculated for every port by means of the following equation:

$$PSAFEXT Loss (f)_N = -10 \log_{10} \sum_{j=1}^m 10^{\frac{-AFEXT Loss (f)_{N,j}}{10}} dB \tag{3-2}$$

where the function $AFEXT Loss (f)_{N,j}$ represents the magnitude (in dB) of the AFEXT Loss at frequency f of the disturbing signal j (1 to m of the relevant disturbing neighbor signals) for the disturbed signal N .

PSAACRF for a disturbed signal N can be calculated for every port by means of the following equation:

$$PSAACRF(f)_N = -10 \log_{10} \sum_{j=1}^m 10^{\frac{-AACRF(f)_{N,j}}{10}} dB \tag{3-3}$$

where the function $AACRF(f)_{N,j}$ represents the magnitude (in dB) of the AACRF at frequency f of the disturbing signal j (1 to m of the relevant disturbing neighbor signals) for the disturbed signal N . The AACRF is calculated by the difference of the AFEXT Loss and the insertion loss magnitudes (in dB) of the disturbed link by the following equation:

$$AACRF(f)_{N,j} = AFEXT Loss (f)_{N,j} - IL(f)_N \quad dB \tag{3-4}$$

The propagation delay is defined as the phase delay of the transmitted signal. It can be calculated from the expanded phase angle of the S_{dd21} parameter by equation (3-5) as described in [4].

$$t_d = -Phase (S_{dd21}) / (360 \cdot f) \quad f \text{ in Hz, } t_d \text{ in s, phase angle in degree} \tag{3-5}$$

The coupling attenuation a_C of the device under test is calculated by equation (3-6) as follows as described in [5] and [6].

$$a_C = a_{m,min} + 4.77 \text{ dB} \quad (3-6)$$

where

- a_C is the coupling attenuation related to the normalized radiating impedance of 150 Ω in dB;
- $a_{m,min}$ is the attenuation recorded as minimum envelope curve of the measured values in dB;
- 4.77 dB is the correction factor for a characteristic differential mode impedance of 100 Ω of the device under test derived from the formula $10 \cdot \log_{10} \left| \frac{300 \Omega}{100 \Omega} \right|$ in dB.

The screening attenuation a_S of the device under test is calculated by equation (3-7) as described in [5] and [6].

3-port measurement setup using VNA without balun shall be used with the differential feeding port set to excite in common mode.

$$a_S = a_{m,min} + 10 \log_{10} \left(\frac{300 \Omega}{Z_1} \right) \text{ dB} \quad (3-7)$$

where

- a_S is the screening attenuation related to the normalized radiating impedance of 150 Ω in dB;
- $a_{m,min}$ is the attenuation recorded as minimum envelope curve of the measured values in dB;
- Z_1 is the characteristic impedance common mode of the cable under test in Ω . It is recommended to use TDR equipment for determining this value.

3.9 ISO and IEC Terminology

ISO and IEC maintain terminological databases for use in standardization at the following addresses:

- ISO Online browsing platform: available at <https://www.iso.org/obp>
- IEC Electropedia: available at <http://www.electropedia.org>

4 General Setup and Settings

4.1 Required Measurement Instruments

The measurement instruments used (VNA, TDR test system and triaxial test tube apparatus) shall fulfill the technical requirements in Table 3.

Table 3: Minimum requirements for measurement instruments

Measured parameter	Equipment	Parameter	Value
S-parameter (excepting cross talk)	VNA	Type	4 ports
		Port reference Impedance	50 Ω single ended
		Window functions ³	Option 1: Hann
			Option 2: Hamming
Frequency range	Option 1 (Hann window) 1G f = 1 MHz to 1000 MHz 2.5G f = 1 MHz to 1400 MHz 5G f = 1 MHz to 2800 MHz 10G f = 1 MHz to 5600 MHz Option 2 (Hamming window) 1G f = 1 MHz to 900 MHz 2.5G f = 1 MHz to 1250 MHz 5G f = 1 MHz to 2500 MHz 10G f = 1 MHz to 5000 MHz		
S-parameter (cross talk)	VNA	Type	4 ports
		Port reference Impedance	50 Ω single ended
		Frequency range	1G f = 1 MHz to 1000 MHz 2.5G f = 1 MHz to 4000 MHz 5G f = 1 MHz to 4000 MHz 10G f = 1 MHz to 4000 MHz
Characteristic impedance (CIDM)	TDR test system	Type	2 channel differential mode
		Port reference impedance	50 Ω single ended / 100 Ω differential mode
		Rise time	Pulse generator: ≤ 25 ps internal (≤ 50 ps at measurement fixture) Rise time needs to be adjustable to the required values (50 ps and 500 ps) All values 10 % to 90 %

³ Other window functions may be used. In this case, the required frequency range shall be adjusted accordingly.

Coupling and screening attenuation	VNA	Type	3-port vector network analyzer
		Port reference Impedance	50 Ω single ended
		Frequency range	f = 30 MHz to 4000 MHz
	Triaxial test tube apparatus	<u>Connector, cable assembly and communication channel measurements:</u>	
		Metallic non ferromagnetic triaxial test tube arrangement according to [5] with lengths as specified in 7.2.1, 7.2.3 and 7.2.4 with inner extension tube of variable length (tube in tube).	
		<u>Cable measurements:</u>	
		Metallic non ferromagnetic standard test tube arrangement according to [6] with lengths as specified in 7.2.2.	
		The test tube diameter depends on the geometric dimension of the DUT. If there are no DUT specific restrictions, a diameter of 40 mm or smaller is recommended. The test tube apparatus needs to be free of higher order modes in the frequency range under test. Commercially available tube devices may be used. For the measurement of angled connectors, angled triaxial corner adapters may be needed.	

Time Domain based measurement instruments may also be used to measure mixed mode S-parameters if they can translate to the VNA settings in Table 4 and fulfill the calibration accuracy requirements in Table 5.

VNAs may also be used to perform impedance measurements, if the instrument can provide an equivalent pulse with 50 ps / 500 ps rise time as specified in Table 3. In this case, the requirement for 25 ps internal and 50 ps at the measurement fixture does not apply. The measurement should be carried out with the recommended VNA settings given in Table 7. The comparability of the time domain results measured with a VNA to results captured with a TDR should be demonstrated depending on the specific equipment type.

The upper and lower frequency of the test setup is limited by the dimensions of the tube, the electrical length of the DUT and other factors. These limitations need to be disclosed and agreed on between client and measurement service provider.

4.2 Vector Network Analyzer Settings and Calibration

To achieve high degree of comparability of test results, the VNA settings given in Table 4 are recommended. The used value for each parameter of Table 4 shall be documented in the measurement report. If measurements are performed with settings related to a higher speed grade, lower speed grades are covered as well. It is not necessary to perform separate measurements with the specific settings for each speed grade. For example, if measurements are carried out with settings for 10G, the measurement results are valid to 5G, 2.5G and 1G as well. The measurement result shall be evaluated within the frequency ranges defined in the electrical requirements in Chapter 7 for the specific speed grades.

Table 4: Recommended VNA settings for measurements in frequency domain

Parameter	Value
Sweep f_{start}	1 MHz
Sweep f_{stop}	1G 2000 MHz 2.5G 2000 MHz (4000 MHz for cross talk) 5G 3000 MHz (4000 MHz for cross talk) 10G 5000 MHz (4000 MHz for cross talk)
Sweep type	linear
Sweep step size	1 MHz
Measurement bandwidth	≤ 3 kHz
Port reference impedance differential mode	100 Ω
Port reference impedance common mode	25 Ω
Data calibration kit (VNA)	Used kit for calibration
Averaging function	May be applied, but not mandatory
Smoothing function	Deactivated

The VNA calibration accuracy shall be verified by a direct Thru connection between the differential ports at the calibration plane (Figure 6). If the connectors of the coaxial measurement cables are of the same gender on both differential ports, a matched pair of coaxial precision adaptors is recommended to connect the measurement cables. If the measurement cables are of complementary gender, the measurement cables shall be unplugged and re-plugged after the calibration process before the calibration accuracy verification is performed.

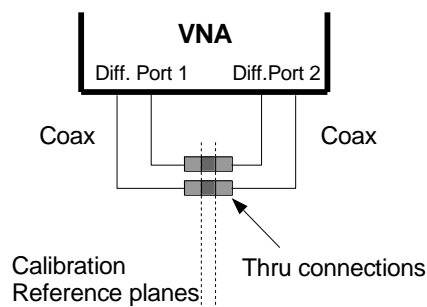

Figure 6: Thru-thru connection for verification of VNA calibration accuracy

The Thru connection of the VNA shall comply with the requirements given in Table 5. The values are derived from the most stringent electrical parameter to be measured, plus an additional margin to reduce measurement uncertainty. RL is derived from the connector requirements, LCL and LCTL from the measurement of triaxial termination load. The evaluation of MDI test heads for 1G is not covered by these settings.

Table 5: VNA calibration accuracy requirements

Test parameter	Related S-parameter	Speed grade	Requirement
RL	S_{dd11}, S_{dd22}	1G	$\geq 36 \text{ dB}$ $1 \leq f \leq 600$, frequency f in MHz
		2.5G	$\geq 36 \text{ dB}$ $1 \leq f \leq 1000$, frequency f in MHz
		5G	$\geq \begin{pmatrix} 36 & 1 \leq f < 1500 \\ 36 - 16.6 \log_{10}(f/1500) & 1500 \leq f \leq 2000 \end{pmatrix} \text{ dB}$ $1 \leq f \leq 2000$, frequency f in MHz
		10G	$\geq \begin{pmatrix} 36 & 1 \leq f < 1500 \\ 36 - 16.6 \log_{10}(f/1500) & 1500 \leq f < 3000 \\ 31 & 3000 \leq f \leq 4000 \end{pmatrix} \text{ dB}$ $1 \leq f \leq 4000$, frequency f in MHz
LCL LCTL	S_{dc11}, S_{dc22} S_{dc21}, S_{dc12}	1G	$\geq 35 \text{ dB}$ $1 \leq f \leq 600$, frequency f in MHz
		2.5G	$\geq 35 \text{ dB}$ $1 \leq f \leq 1000$, frequency f in MHz
		5G	$\geq 35 \text{ dB}$ $1 \leq f \leq 2000$, frequency f in MHz
		10G	$\geq 35 \text{ dB}$ $1 \leq f \leq 4000$, frequency f in MHz

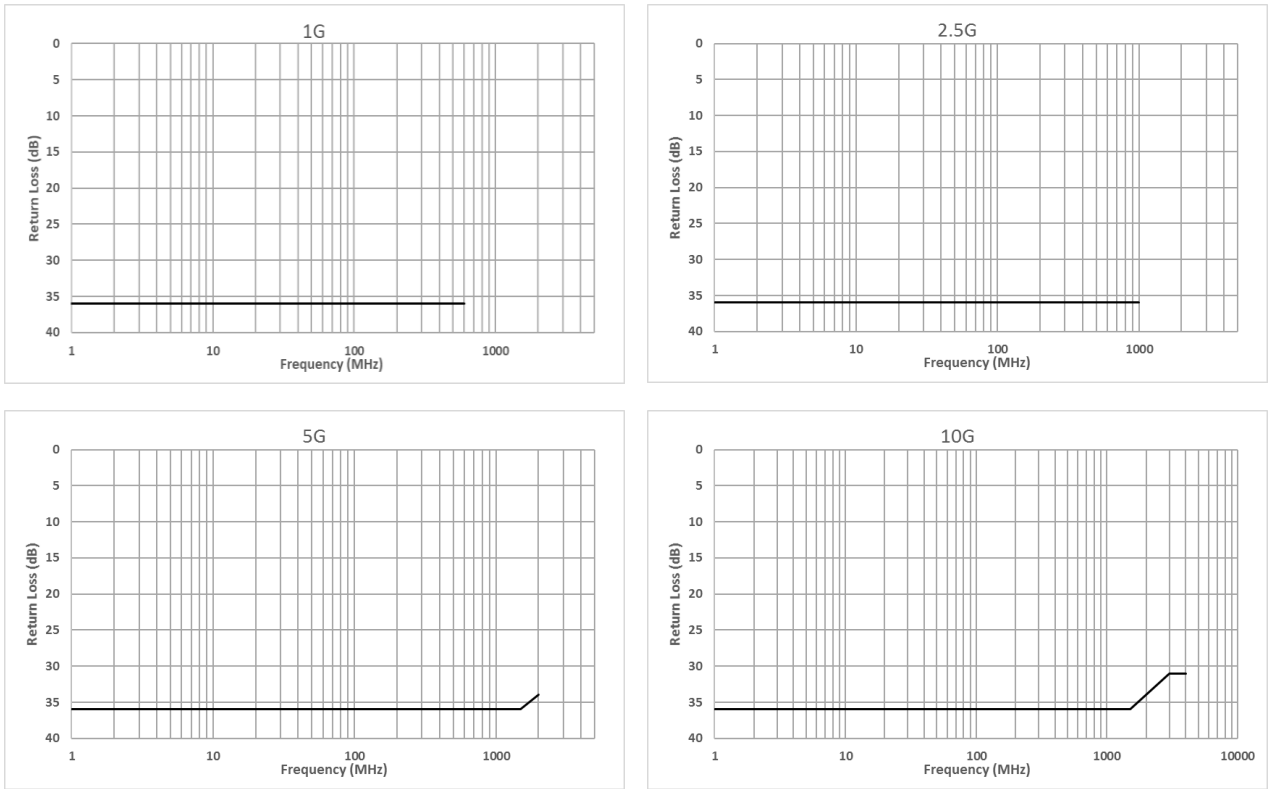

Figure 7: Return loss requirements for VNA calibration accuracy

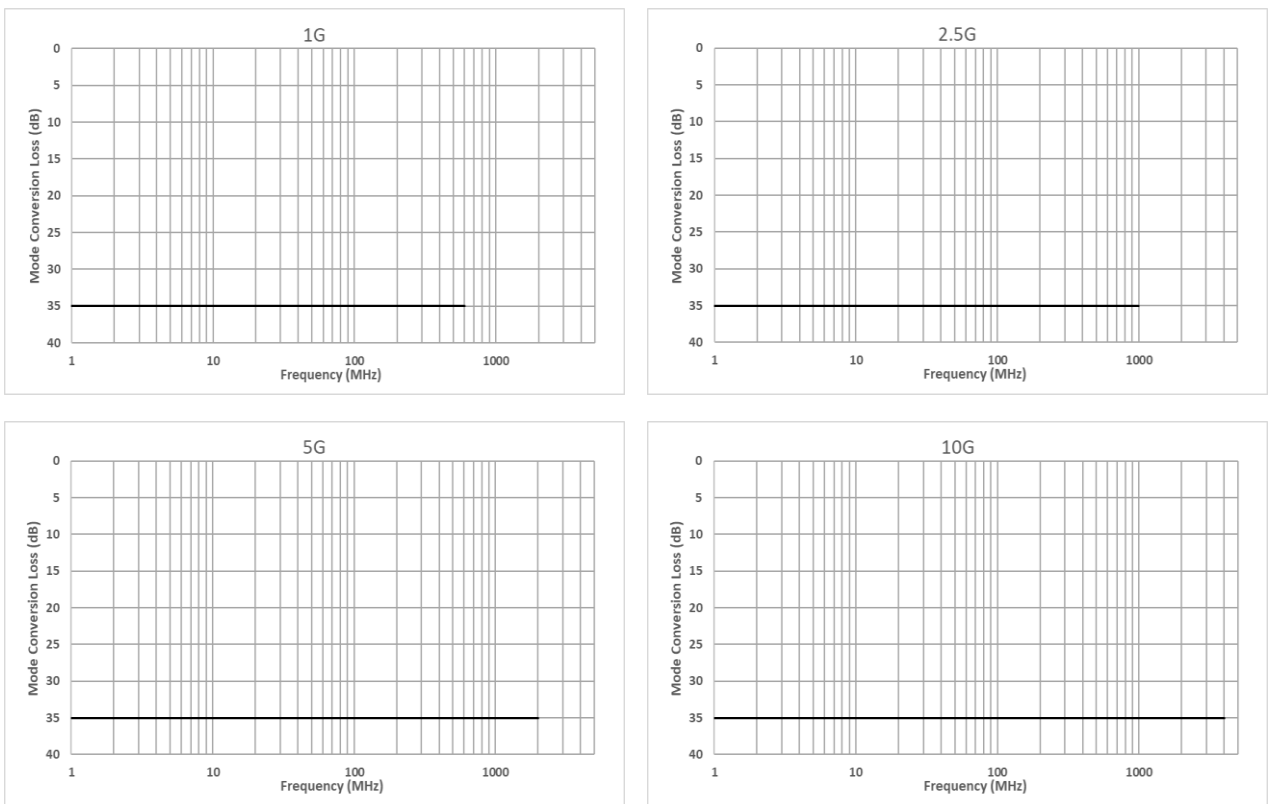

Figure 8: LCL / LCTL requirement for VNA calibration accuracy

The dynamic range of the VNA is most critical in measurements of crosstalk and screening and coupling attenuation. The VNA’s measurement dynamic range can be evaluated by measuring IL as a noise floor

against terminated coaxial connectors for information only. The instruments dynamic range may be improved by increasing the output power, by applying an averaging function or by reducing of measurement bandwidth at the cost of a slower measurement. It is recommended to follow the instructions of the equipment manufacturer to find optimal settings.

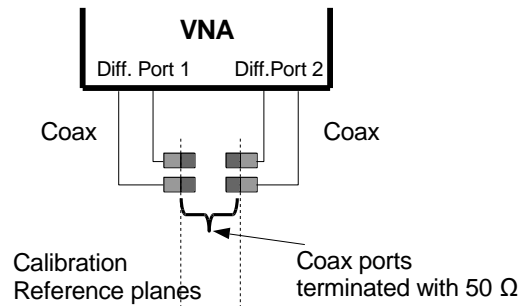

Figure 9: Verification of VNA dynamic range

Table 6: VNA dynamic range recommendation

Test parameter	Related S-parameter	Speed grade	Requirement
IL	S_{dd21}	1G	$\geq \begin{pmatrix} 80 & 1 \leq f \leq 215 \\ 85 - 15 \log_{10}(f/100) & 215 < f \leq 600 \end{pmatrix} dB$ $1 \leq f \leq 600, \text{ frequency } f \text{ in MHz}$
		2.5G	$\geq \begin{pmatrix} 80 & 1 \leq f \leq 215 \\ 85 - 15 \log_{10}(f/100) & 215 < f \leq 1000 \end{pmatrix} dB$ $1 \leq f \leq 1000, \text{ frequency } f \text{ in MHz}$
		5G	$\geq \begin{pmatrix} 80 & 1 \leq f \leq 215 \\ 85 - 15 \log_{10}(f/100) & 215 < f \leq 2000 \end{pmatrix} dB$ $1 \leq f \leq 2000, \text{ frequency } f \text{ in MHz}$
		10G	$\geq \begin{pmatrix} 80 & 1 \leq f \leq 215 \\ 85 - 15 \log_{10}(f/100) & 215 < f \leq 4000 \end{pmatrix} dB$ $1 \leq f \leq 4000, \text{ frequency } f \text{ in MHz}$

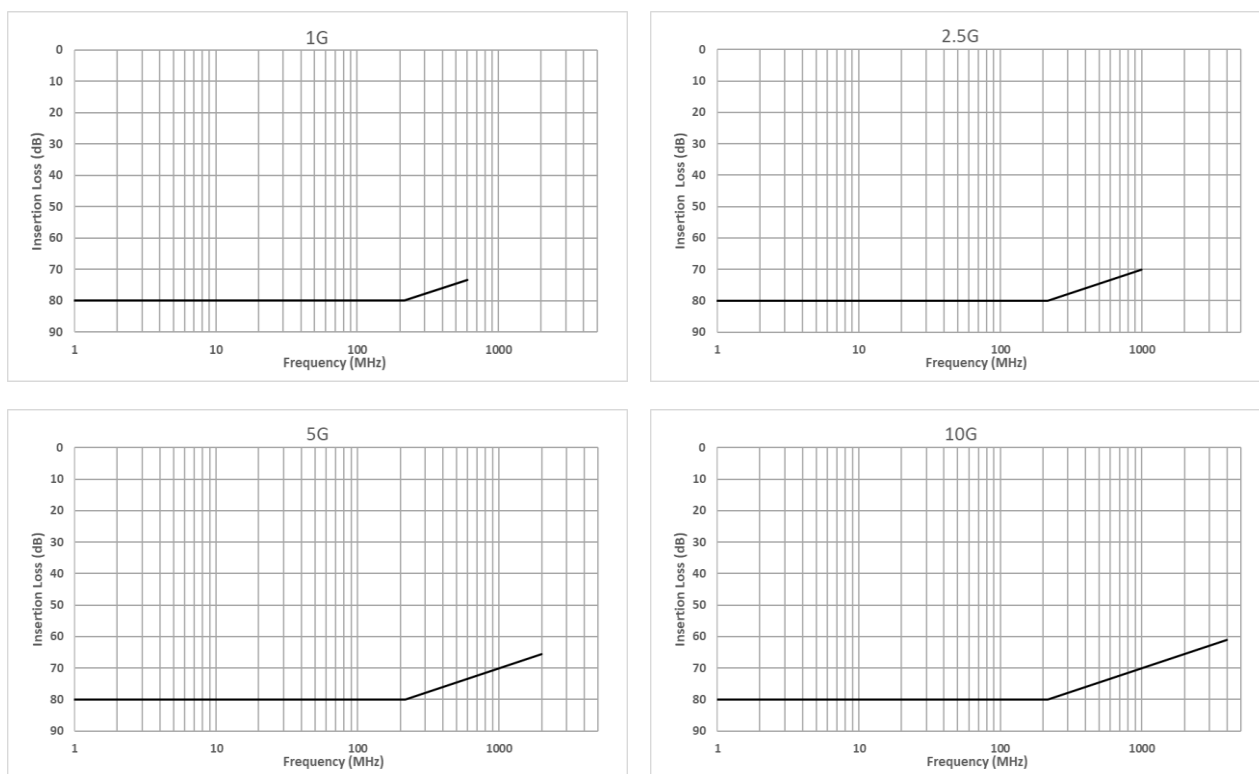

Figure 10: Insertion loss requirements for VNA calibration accuracy

If impedance measurements are carried out by VNA, the following settings are recommended to get results equivalent to a TDR test system.

Table 7: Recommended VNA settings for time domain impedance measurement

Parameter	Value
Frequency range ⁴	Option1 (Hann window) f = 1 MHz to 2000 MHz (500 ps) (for cables, connectors and communication channels) f = 10 MHz to 20 GHz (50 ps) (for characterization of measurement fixtures and MDI test heads)
	Option2 (Hamming window) f = 1 MHz to 1900 MHz (500 ps) (for cables, connectors and communication channels) f = 10 MHz to 19 GHz (50 ps) (for characterization of measurement fixtures and MDI test heads)
Sweep type	Linear
Sweep step size	1 MHz

⁴ Other window functions may be used. In this case, the frequency range shall be adjusted accordingly.

Filtering ⁴	Option 1: Hann window
	Option 2: Hamming window
TDR Type	Step
Measurement bandwidth	≤ 3 kHz
Port reference impedances	50 Ω single ended port impedances (This results in 100 Ω differential mode reference impedance after conversion to mixed mode parameters.)
Data calibration kit (VNA)	Used kit for calibration
Averaging function	May be applied, but not mandatory
Smoothing function	Deactivated

To achieve high degree of comparability of measurement results, the VNA settings given in Table 8 are recommended for screening and coupling attenuation measurements. The used value for each parameter shall be documented in the measurement report.

Table 8: Recommended VNA settings for coupling and screening attenuation measurements

Parameter	Value
Sweep f_{Start}	30 MHz
Sweep f_{Stop}	1G 600 MHz 2.5G 4000 MHz 5G 4000 MHz 10G 4000 MHz
Sweep type	Linear
Sweep step size	2 MHz
Measurement bandwidth	≤ 1 kHz
Port reference impedance differential mode	100 Ω
Port reference impedance common mode	25 Ω
Data calibration kit (VNA)	Used kit for calibration
Averaging function	May be applied, but not mandatory
Smoothing function	Deactivated

4.3 De-embedding Software Check (informative)

The purpose of de-embedding software check is to determine and to document the accuracy of the de-embedding tool. The accuracy is measured by comparing the result of the tool with a "known result". This shall enable the user to compare the accuracy of different de-embedding tools and assist in selecting appropriate tools to perform the measurements described within this document. The verification process is

described in [9]. It defines three different options of “known results”. The following two options are recommended for the de-embedding software verification since both allow to obtain S-parameters for a known DUT (“known result”) and a corresponding de-embedded DUT (result from the de-embedding tool):

- Option 1: Using synthesized DUT and fixture models, i.e., simulated S-parameter sets
- Option 2: Using separately measured fixture and DUT S-parameters from special test structures

The de-embedding result is compared to the known result by calculating the magnitudes of the absolute error vector for reflection parameters (RL) and the relative error vector for transmission parameter (IL) at each frequency by the equations (4.3-1) and (4.3-2). S^A and S^B are the corresponding S-parameters for the known DUT (A) and the de-embedded DUT (B) respectively.

$$Absolute\ Error = 20 \cdot \log(|S_{dii}^A - S_{dii}^B|) \text{ dB} \tag{4.3-1}$$

where ii is 11 or 22 respectively, corresponding to the reflection parameter from left side or right side

$$Relative\ Error = 20 \cdot \log\left(\frac{|S_{dd21}^A - S_{dd21}^B|}{(|S_{dd21}^B|)}\right) \text{ dB} \tag{4.3-2}$$

The informative acceptance criterion for the absolute and for the relative error is ≤ -20 dB.

4.4 De-embedding Measurement Results Consistency Tests

4.4.1 De-embedding Consistency Test #1: Self-de-embedding of 2X-Thru

The purpose of self-de-embedding consistency check is to determine and to document the accuracy of the de-embedding method. The verification process is described in [9] (Consistency test #1).

The consistency of the de-embedded result shall be checked by self-de-embedding the 2X-Thru. The unprocessed 2X-Thru measurement result is compared to the measurement fixture models generated by the de-embedding tool. After self-de-embedding the unprocessed 2X-Thru with the generated 2X-Thru, depending on the accuracy of the de-embedding tool and the DUT, the result is expected to be an electrically transparent interconnect.

The impedance deviation between the fixture on both sides of the DUT used to de-embed the DUT from the FIX-DUT-FIX measurement, measured at a defined TDR rise time of the measured speed grade, shall not exceed ± 5 % difference with reference to the FIX-DUT-FIX measurement.

The residual magnitude and phase deviation of S_{dd21} and the CIDM deviations shall fulfill the requirements in Table 9.

Table 9: Consistency requirements for self-de-embedded 2X-Thru for de-embedded measurements

Test parameter	Symbol or related S-parameter	Speed grade	Requirement
CIDM	Z_{RF}	All	± 5 % impedance deviation (at 170 ps rise time)
IL Magnitude	S_{dd21}	1G	$-0.1 \text{ dB} \leq (IL \text{ Magnitude}) \leq 0.1 \text{ dB}$ $1 \leq f \leq 600$, frequency f in MHz

		2.5G	$-0.1 \text{ dB} \leq (IL \text{ Magnitude}) \leq 0.1 \text{ dB}$ $1 \leq f \leq 1000$, frequency f in MHz
		5G	$-0.1 \text{ dB} \leq (IL \text{ Magnitude}) \leq 0.1 \text{ dB}$ $1 \leq f \leq 2000$, frequency f in MHz
		10G	$-0.1 \text{ dB} \leq (IL \text{ Magnitude}) \leq 0.1 \text{ dB}$ $1 \leq f \leq 4000$, frequency f in MHz
IL Phase	S_{dd21}	1G	$-1^\circ \leq (IL \text{ Phase}) \leq 1^\circ$ $1 \leq f \leq 600$, frequency f in MHz
		2.5G	$-1^\circ \leq (IL \text{ Phase}) \leq 1^\circ$ $1 \leq f \leq 1000$, frequency f in MHz
		5G	$-1^\circ \leq (IL \text{ Phase}) \leq 1^\circ$ $1 \leq f \leq 2000$, frequency f in MHz
		10G	$-1^\circ \leq (IL \text{ Phase}) \leq 1^\circ$ $1 \leq f \leq 4000$, frequency f in MHz

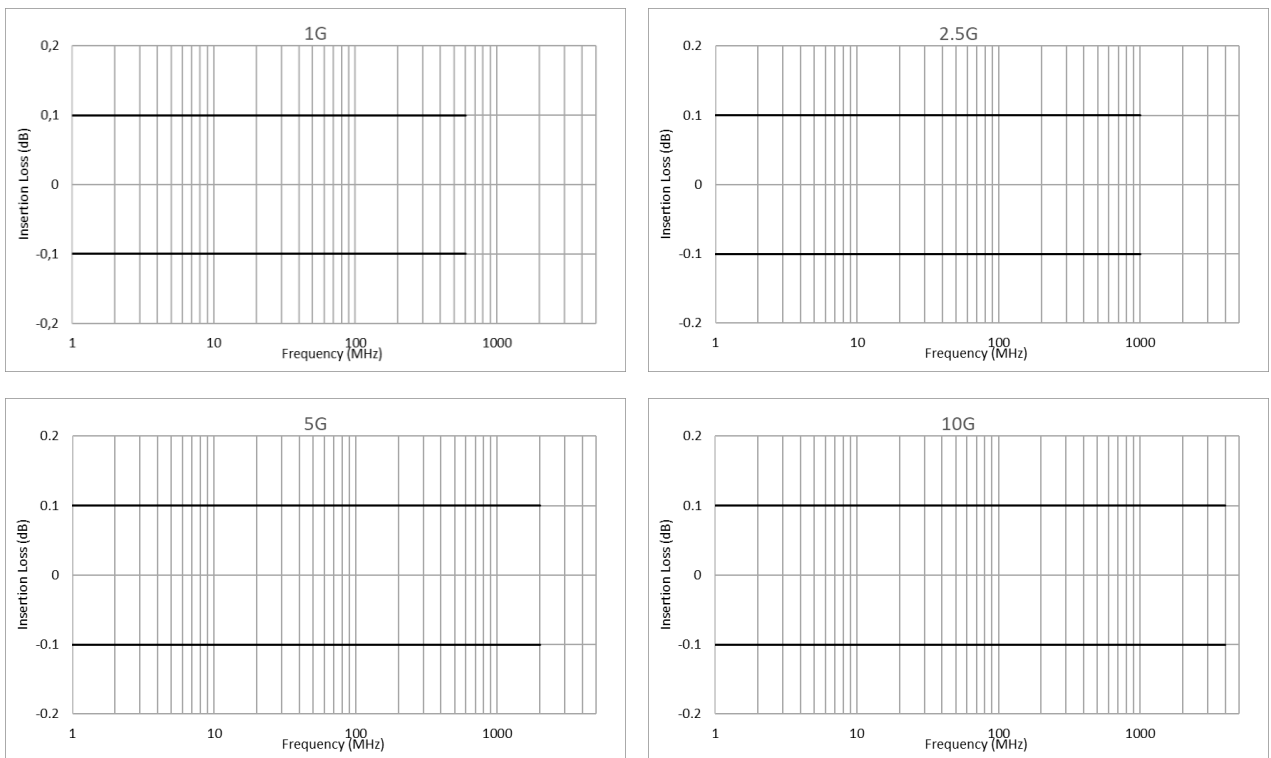

Figure 11: IL magnitude requirement on de-embedding consistency

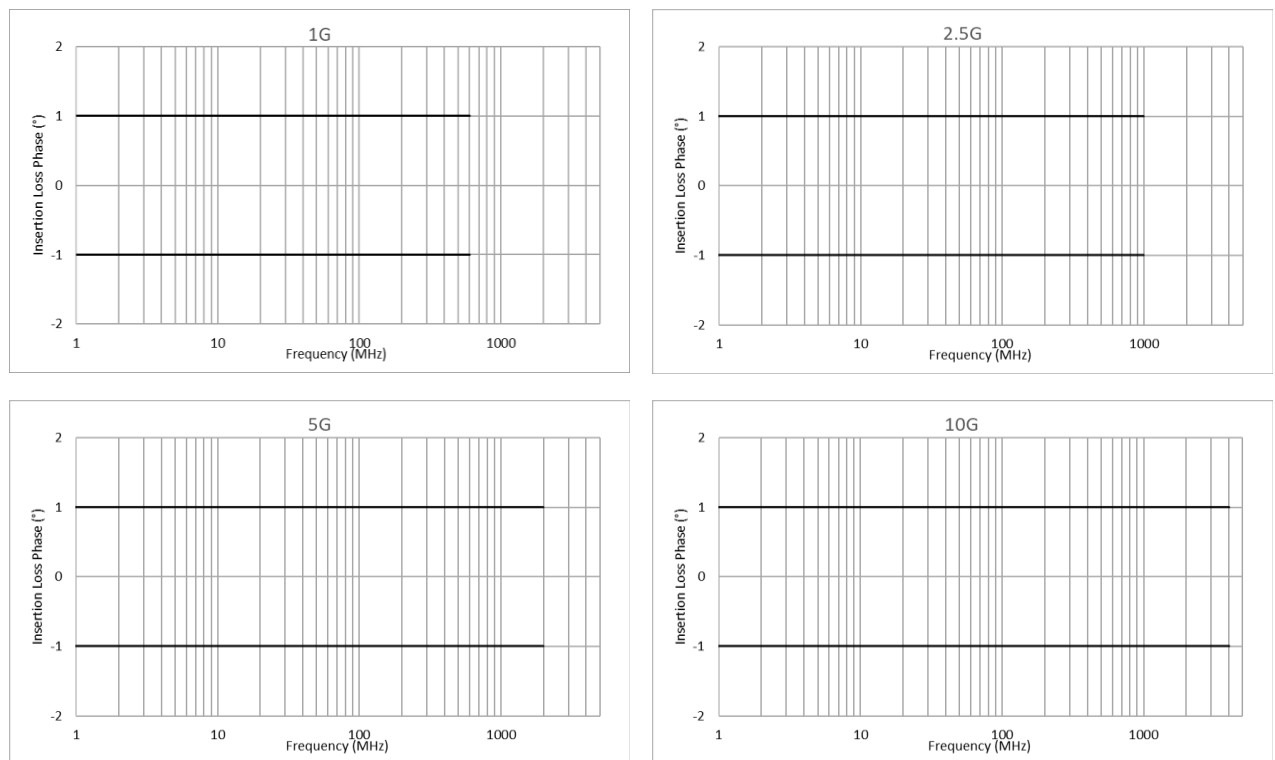

Figure 12: IL phase requirement on de-embedding consistency

4.4.2 De-embedding Consistency Test #2: TDR Comparison of Fixture Model to FIX-DUT-FIX

The purpose of the TDR comparison test is to document that the fixture model used for the de-embedding process is identical to the fixture in the measured FIX-DUT-FIX structure. The fixture model is derived by the de-embedding algorithm out of the 2X-Thru reference measurement as described in 6.1.1, method A. The comparison process is also described in [9] (Consistency test #2).

An important assumption in the de-embedding process is that the model of the fixture used to de-embed the DUT from the FIX-DUT-FIX structure is identical to the fixture attached to the DUT. The matching between the fixture model and the fixture attached to the DUT shall be documented by calculating the TDR response from the S-parameters of fixture model and FIX-DUT-FIX structure and showing them in the same diagram. This documentation demonstrates the capability of the de-embedding tool chain and its correct use as part of the setup validation process. For this reason, the TDR comparison needs only be done once. Comparing of the fixtures TDR responses for each individual FIX-DUT-FIX in a complete test group is not required. Figure 13 illustrates the TDR comparison for the fixture on the left side of the DUT. The same procedure shall also be performed for the fixture on the right side to complete the de-embedding consistency test #2.

FIX-DUT-FIX Structure:

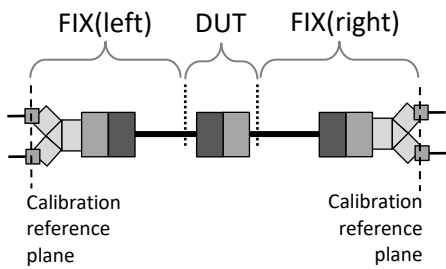

Fixture Model:

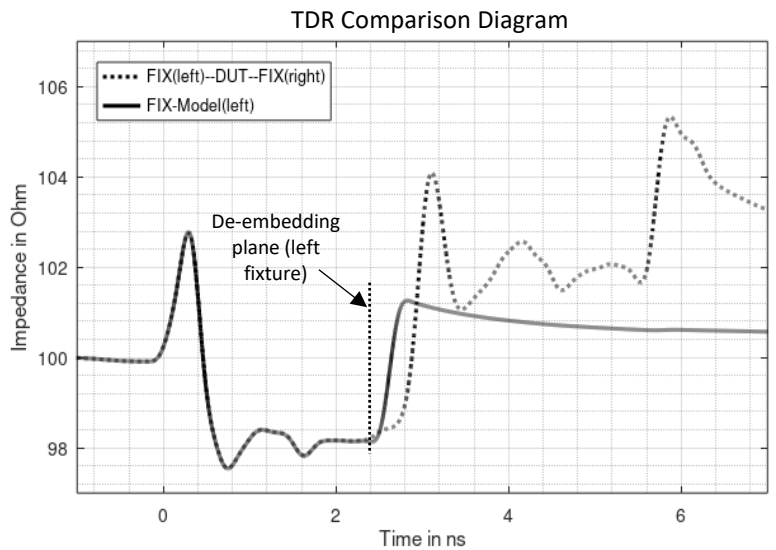
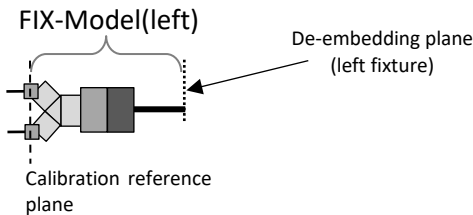

Figure 13: Consistency test #2 - comparison of fixture model and FIX-DUT-FIX structure, example for inline connector de-embedding

4.5 Handling Instructions

To assure a high degree of reliability for the measurements, the following precautions are required ([3]):

Measurement fixtures shall fulfil the requirements in Chapter 5. The reference plane of the calibration shall coincide with the measurement reference plane. In case of differences, the magnitude of errors shall be determined. For connector measurements, the measurement reference plane shall be shifted towards the evaluation windows by using gating methods.

1. Termination resistor loads shall have a single ended return loss of at least 30 dB at the maximum frequency (f_{stop} in Table 4), if not specified otherwise in Chapters 5 and 6.
2. The cables shall be placed to satisfy the requirements of the specific test and needs to be fixed throughout the test sequence.
3. Stress on cables and adapters, as caused by physical flexing, sharp bends and restraints shall be avoided before, during and after the tests. Test cables and adapters shall be selected for high phase stability to meet the requirements in Table 5 during the complete test sequences including handling operations for connecting and disconnecting the DUTs.
4. The phase reference plane may optionally be moved to the DUT by VNA features such as “port extension”. The detailed description of such techniques is not scope of this document and the correct application shall be demonstrated and documented.
5. Phase stable VNA test cables shall be used. Coaxial cables between measurement instruments and measurement fixtures, shall be chosen in a way that the calibration requirements in Table 5 are fulfilled.
6. Overload conditions of the measurement instruments shall be avoided.
7. The VNA shall provide sufficient stability with low electrical drift to meet the accuracy requirements in Table 5 during the entire test sequence.
8. To find the correct mating position, the housing of the connector (socket or plug) shall be taken with two fingers, either thumb and index finger or thumb and middle finger as shown in Figure 14. Push together to completely mate the connector pair, stop when maximum overlap is reached (blocking) and

finally release while leaving the mating position unchanged. RF measurements shall be performed in this connector mating position unless specified otherwise by product specific standards such as OEM or industry specific product qualification standards.

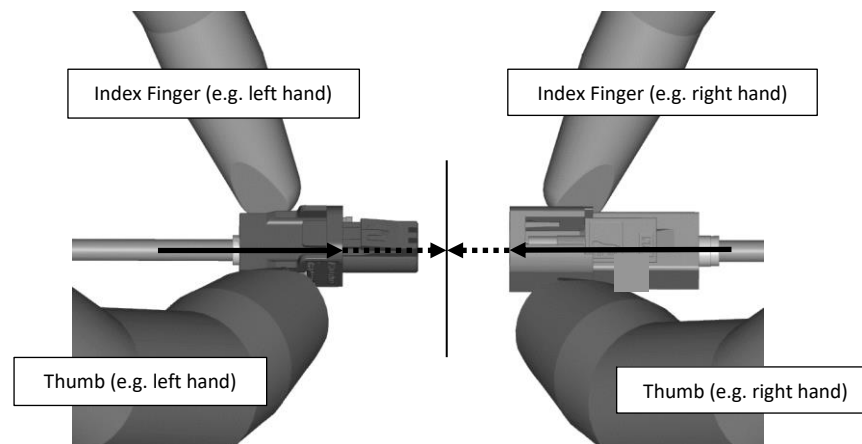

Figure 14: Finding the nominal mating position

4.6 Presentation of Measurement Results

Test results shall be documented in the following way:

- Documentation of test conditions (e.g. humidity, temperature, cable length)
- Documentation of cable types, cable length and production number (also for S-parameter and screening / coupling attenuation measurements of connectors)
- Documentation of used calibration kit and of calibration accuracy in thru-thru configuration
- Pictures of test set-up and measurement fixture
- Documentation of measurement fixture characterization and of optional correction methods such as fixture de-embedding, phase correction, re-normalization, absolute gate positions etc.
- Results for S-parameter
 - Result as dB value with related limit
 - Diagram with logarithmic or linear frequency axis up to minimal

1G	f = 600 MHz
2.5G	f = 1000 MHz
5G	f = 2000 MHz
10G	f = 4000 MHz
- Results for TDR Measurements
 - Result as differential impedance (Ohms) with related limit
 - Measurement result is to be presented in one diagram in the following format:
 - Linear scale for X axis in time as measured (travel time for reflected signal forth and back)
 - Linear scale for additional X axis in equivalent length (calculated using 2/3 of c_0 or real phase velocity of the DUT and measured travel time for reflected signal divided by two)
- Diagrams in test reports and similar documents shall have consistent scaling allowing easy comparison of related measurements and clear recognition of test results and limits.

The S-parameters may be provided as data files for further use. In this case, the use of data exchange formats according to [10] is recommended.

5 Measurement Fixtures and Terminations

5.1 Measurement Fixture Requirements for De-Embedding

For measurements that are performed using de-embedding, the fixture electrical requirements (FERs) as given in Table 10 shall apply. The FER class definition corresponds to the description in [9] where class A has the most stringent design requirement, and class C has the least stringent. The need for a specific FER class depends on the used de-embedding technique. A less sophisticated technique may require more stringent fixture classes. Table 10 lists the minimum requirements for the fixtures. Chapter 4.3 describes a method for verification if a particular de-embedding technique works accurate enough with these minimum requirements. More stringent FER classes may be used depending on the specific de-embedding technique.

Table 10: Minimum fixture electrical requirements (FER) for de-embedding

FER	Description	FER Class and Requirement per Use Case		
		Cables	Mated Connector Pairs	Cable Assemblies and Channels
FER 1	IL of 2X-Thru	Class C: $IL \leq 15 \text{ dB}, f_{min} \leq f \leq f_{max}$		
FER 2	RL of 2X-Thru	Class C: $RL \geq 6 \text{ dB}, f_{min} \leq f \leq f_{max}$		
FER 3	Difference between RL and IL of 2X-Thru	Class B, C: $(RL - IL) \geq 0 \text{ dB}, f_{min} \leq f \leq f_{max}$		
FER 5	Fixture impedance difference between FIX in 2X-Thru and FIX-DUT-FIX	Class C: $\pm 10 \Omega$, Hann window ⁵ : $tr = 0.97/f_{max}$ Hamming window ⁵ : $tr = 0.91/f_{max}$		
FER 6	Difference between IL and TCTL for 2X-Thru	Class A, B, C: $20 \log_{10} \left(\frac{S_{dcz1}}{S_{ddz1}} \right) \text{ dB} \leq -15 \text{ dB}$, $f_{min} \leq f \leq f_{max}$		
FER 8	Minimum length of 2X-Thru	Class A, B, C: $Phase(S_{ddz1}) \leq -1080^\circ, f = f_{max}$		

The frequency bandwidth from f_{min} to f_{max} depends on the speed grade and corresponds to the frequency ranges given in Table 4. The maximum frequency f_{max} may be increased if the 2xThru is too short to meet FER 8. FER 6 does not apply to de-embedding methods that take mode conversion into account.

5.2 Measurement Fixture Requirements for Direct Measurement

5.2.1 General Measurement

Measurements are performed using fixtures that adapt from an automotive connector to coaxial connectors. These shall be available with socket or plug automotive connector to allow measuring a mated pair of measurement fixtures. How measurement fixtures are physically implemented is not constrained by this document, e.g. whether based on PCBs or not. Examples for measurement fixtures are given in Annex A.1. The requirements on measurement fixtures shall apply to direct measurements, where de-embedding

⁵ It is recommended to calculate the fixture impedances from the corresponding S-parameters, e.g. by using the time domain conversion feature of the VNA. The resulting rise time depends on the frequency bandwidth of the S-parameters and the window function used by the time domain conversion algorithm. Other window functions may be used. In this case, the rise time changes accordingly.

is not used, unless other specified. Different or additional requirements on direct measurement fixtures are defined, e.g. for connector measurement fixtures, cable measurement fixtures and MDI test heads.

Unique numbers shall be assigned to the measurement fixtures to allow individual identification. The mated measurement fixture pair as shown in Figure 15 shall fulfill the electrical requirements in Table 11.

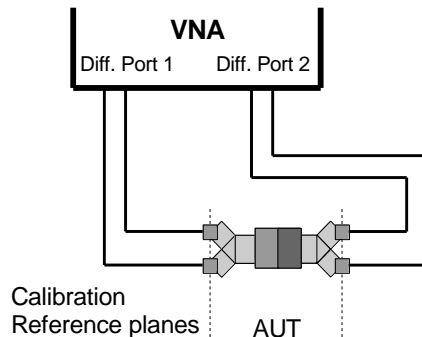

Figure 15: Validation of mated measurement fixture pair

Table 11: Return loss and balance requirements for mated measurement fixture pair

Test parameter	Symbol or related S-parameter	Speed grade	Requirement
RL	S_{dd11}, S_{dd22}	1G	$\geq 25 \text{ dB}$ $1 \leq f \leq 600$, frequency f in MHz
		2.5G	$\geq 25 \text{ dB}$ $1 \leq f \leq 1000$, frequency f in MHz
		5G	$\geq \left(\begin{matrix} 25 & 1 \leq f < 1500 \\ 25 - 16.6 \log_{10}(f/1500) & 1500 \leq f \leq 2000 \end{matrix} \right) \text{ dB}$ $1 \leq f \leq 2000$, frequency f in MHz
		10G	$\geq \left(\begin{matrix} 25 & 1 \leq f < 1500 \\ 25 - 16.6 \log_{10}(f/1500) & 1500 \leq f < 3000 \\ 20 & 3000 \leq f \leq 4000 \end{matrix} \right) \text{ dB}$ $1 \leq f \leq 4000$, frequency f in MHz
LCL LCTL	S_{dc11}, S_{dc22} S_{dc21}, S_{dc12}	1G	$\geq 30 \text{ dB}$ $1 \leq f \leq 600$, frequency f in MHz
		2.5G	$\geq 30 \text{ dB}$ $1 \leq f \leq 1000$, frequency f in MHz
		5G	$\geq 30 \text{ dB}$ $1 \leq f \leq 2000$, frequency f in MHz
		10G	$\geq 30 \text{ dB}$ $1 \leq f \leq 4000$, frequency f in MHz

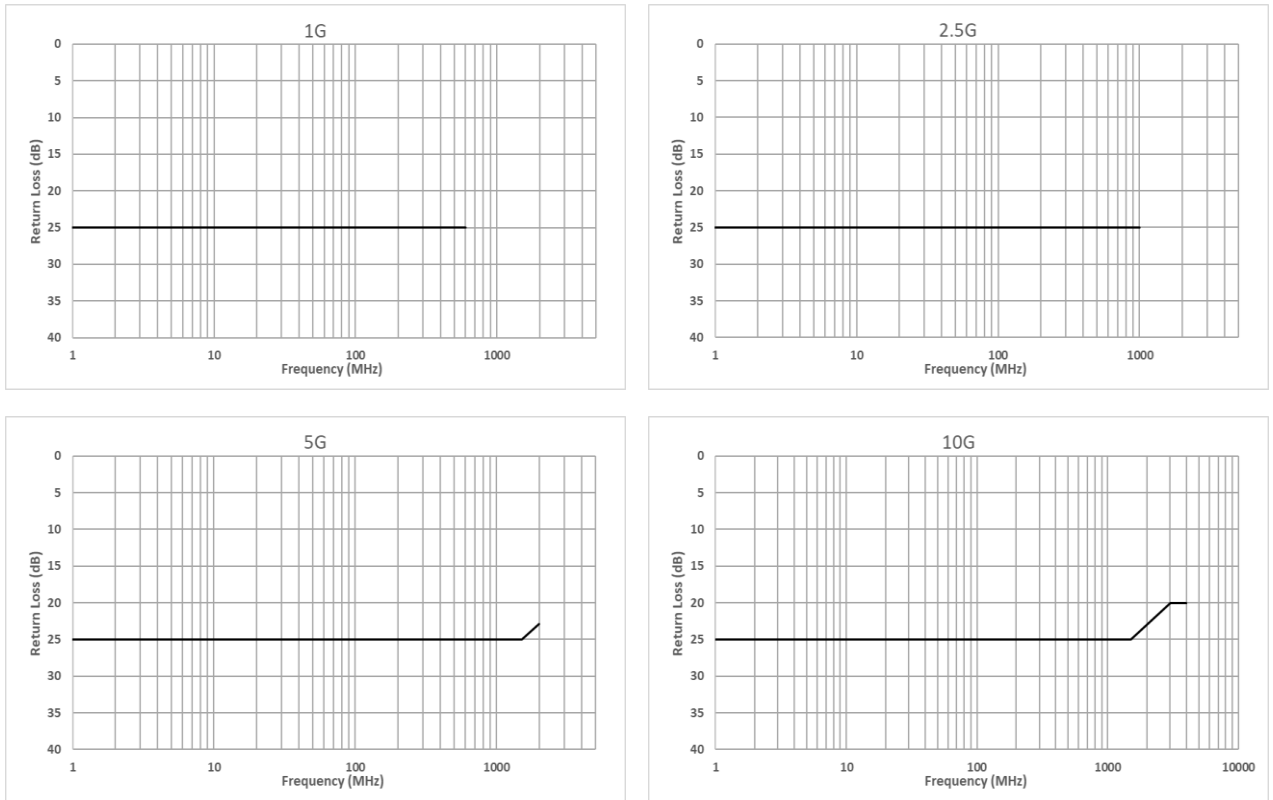

Figure 16: Return loss requirements for mated measurement fixture pair

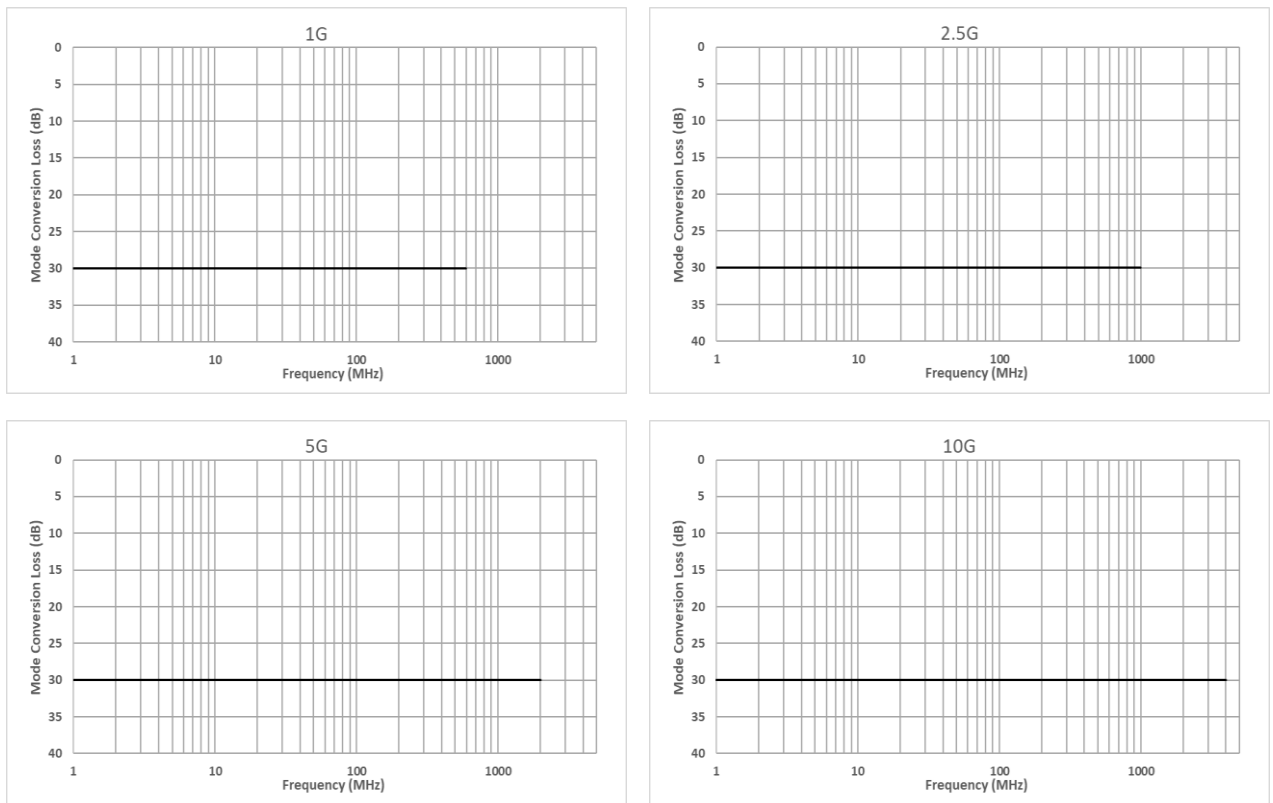

Figure 17: Balance requirements for mated measurement fixture pair

5.2.2 Connectors

For connector measurements and detailed cable assembly analysis as in Annex C, the interface section of the mated measurement fixture pair shall be measured in addition to the mated measurement fixture pair as in 5.2.1. The gating procedure as described in 6.1.1 shall be applied, but with the start gate set to -150 ps and stop gate set to +150 ps.

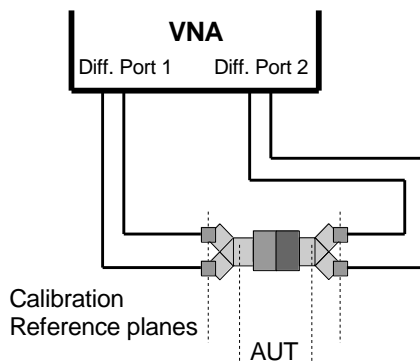

Figure 18: Validation of interface section of the mated measurement fixture pair

Table 12: Return loss requirements for the gated interface section of the mated measurement fixture pair

Test parameter	Symbol or related S-parameter	Speed grade	Requirement
RL	S_{dd11}, S_{dd22}	1G	$\geq 30 \text{ dB}$ $1 \leq f \leq 600$, frequency f in MHz
		2.5G	$\geq 30 \text{ dB}$ $1 \leq f \leq 1000$, frequency f in MHz
		5G	$\geq \begin{pmatrix} 30 & 1 \leq f < 1500 \\ 30 - 16.6 \log_{10}(f/1500) & 1500 \leq f \leq 2000 \end{pmatrix} \text{ dB}$ $1 \leq f \leq 2000$, frequency f in MHz
		10G	$\geq \begin{pmatrix} 30 & 1 \leq f < 1500 \\ 30 - 16.6 \log_{10}(f/1500) & 1500 \leq f < 3000 \\ 25 & 3000 \leq f \leq 4000 \end{pmatrix} \text{ dB}$ $1 \leq f \leq 4000$, frequency f in MHz

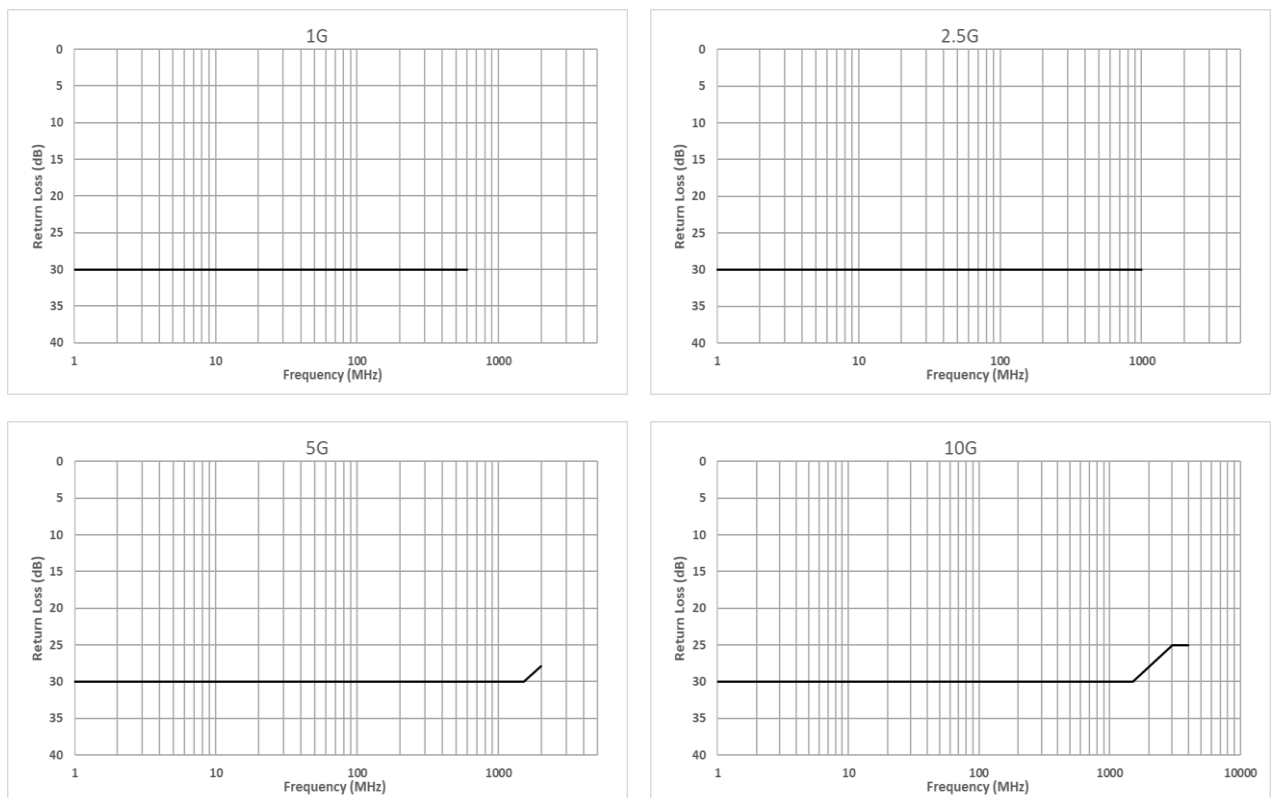

Figure 19: Return loss requirements for the gated interface section of the mated measurement fixture pair

Connectors based on the same connector interface may be available from different manufacturers. Electrical interoperability needs to be assured by minimizing differences in interface design of socket and plug connectors between different vendors.

Manufacturers who provide test samples shall also provide matching pairs of measurement fixtures. Both combinations of mated measurement fixture pairs (vendor 1 socket with vendor 2 plug, vendor 1 plug with vendor 2 socket) shall be tested and shall fulfill the electrical requirements in Table 11.

5.2.3 PCB Connectors

For the measurement of PCB connectors, PCB based measurement fixtures are needed. Measurement fixtures for PCB connectors shall provide electrical and mechanical quality, so that the measurement result is not dominated by the characteristics of the measurement fixtures. Measurement fixtures need to have low insertion loss and very good matching to 50Ω single ended impedance. The differential impedance of traces shall fulfill the requirements in Figure 20. In the area of the transition from the traces to the coaxial connectors, a tolerance of $100 \Omega \pm 10 \Omega$ is allowed as these shall be excluded from the measurement result by choosing a proper stop gate position.

The characteristic impedance differential mode is 100Ω for any measurements. The impedance of measurement fixtures shall be within $100 \Omega \pm 3 \%$ at a rise time of 50 ps. An impedance tolerance of $\pm 10 \%$ is permitted if the 3% limit is exceeded no longer than 120 ps round trip time or 60 ps propagation time (see Figure 20). The PCB connector including its footprint shall be excluded from the measurement fixture impedance requirement.

Table 13: PCB connector measurement fixture impedance requirement

Test Parameter	Symbol or related S-parameter	Speed grade	Requirement
CIDM	Z_{RF}	All	$100 \Omega \pm 3 \Omega$ trace impedance (at 50 ps rise time)

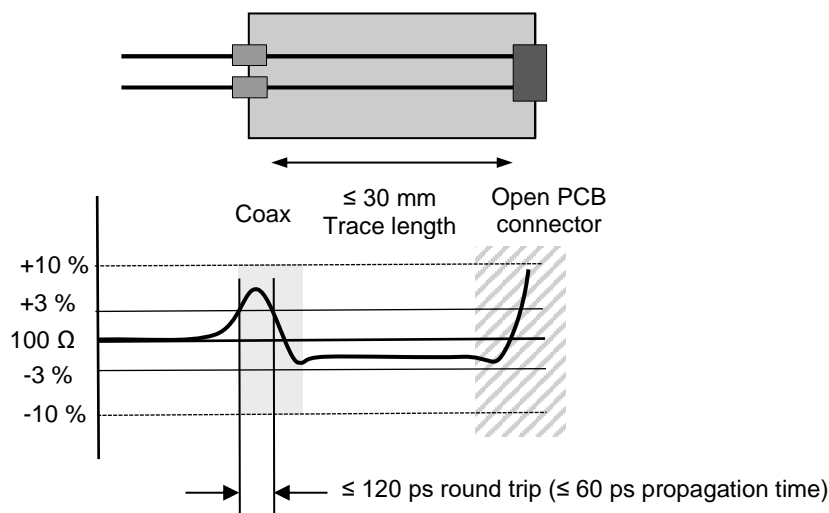

Figure 20: PCB connector measurement fixture characteristic impedance requirement

The maximum recommended trace length of PCB based measurement fixtures is 30 mm. Longer trace lengths are permitted in case of design constraints, e.g. for larger size multiport connectors, if the following requirements are met to avoid inaccurate return loss results:

- Impedance tolerance of the traces smaller than $\pm 3 \%$
or
- Removing the fixture by de-embedding techniques or by shifting the calibration plane to the DUT leads; the detailed description of such techniques is not scope of this document. The correct application of these methods needs to be demonstrated and documented.

When a measurement fixture is used as termination and is not connected to the VNA, it shall provide 50Ω single ended terminations to common ground for each line of the differential pair.

Due to the large variety of possible PCB connectors that include multiport connector types, that may even have ports for other applications than 1G/2.5G/5G/10G, e.g. for coaxial cables, the measurement fixtures or related design guidelines should be provided by the connector manufacturer. Examples of appropriate measurement fixtures are given in Annex A.1.

5.2.4 Multiport PCB Connectors

For the measurement of multiport PCB connectors, the internal near end crosstalk of the measurement fixture needs to be measured without the PCB connector soldered to it as shown in Figure 21. Transmission from each port shall be measured to any neighboring port. Identical trace length for all pairs of the measurement fixture is recommended.

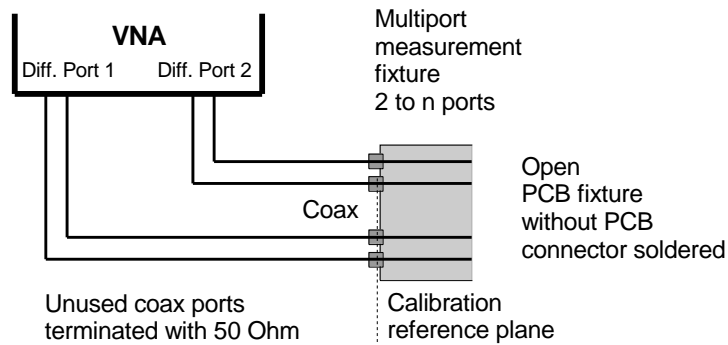

Figure 21: Validation of multiport measurement fixture crosstalk

The validation of measurement fixtures crosstalk shall be carried out exemplarily on an appropriate number of samples per measurement fixture type. It is not required to measure the specific instance that is used in the actual multiport connector measurement, assuming that the electrical variations on PSANEXT Loss caused by manufacturing tolerances of the measurement fixture are low enough. This allows the connector manufacturer to provide multiport connectors that are pre-mounted to a measurement fixture instead of the need to solder them after the measurement fixture characterization.

The internal crosstalk within multiport measurement fixtures shall comply with the requirements in Table 14.

Table 14 Multiport measurement fixture PSANEXT Loss requirements

Test parameter	Symbol or related S-parameter	Speed grade	Requirement
PSANEXT Loss	S_{dd31}, S_{ddyx}	1G	$\geq \begin{pmatrix} 63 - 10 \log_{10} (f/100) & 1 \leq f \leq 100 \\ 63 - 15 \log_{10} (f/100) - 6 (f - 100/400) & 100 < f \leq 600 \end{pmatrix} dB$ $1 \leq f \leq 600, \text{ frequency } f \text{ in MHz}$
		2.5G	$\geq \begin{pmatrix} 80 & 1 \leq f \leq 215 \\ 85 - 15 \log_{10} (f/100) & 215 < f \leq 1000 \end{pmatrix} dB$ $1 \leq f \leq 1000, \text{ frequency } f \text{ in MHz}$
		5G	$\geq \begin{pmatrix} 80 & 1 \leq f \leq 215 \\ 85 - 15 \log_{10} (f/100) & 215 < f \leq 2000 \end{pmatrix} dB$ $1 \leq f \leq 2000, \text{ frequency } f \text{ in MHz}$
		10G	$\geq \begin{pmatrix} 80 & 1 \leq f \leq 215 \\ 85 - 15 \log_{10} (f/100) & 215 < f \leq 4000 \end{pmatrix} dB$ $1 \leq f \leq 4000, \text{ frequency } f \text{ in MHz}$

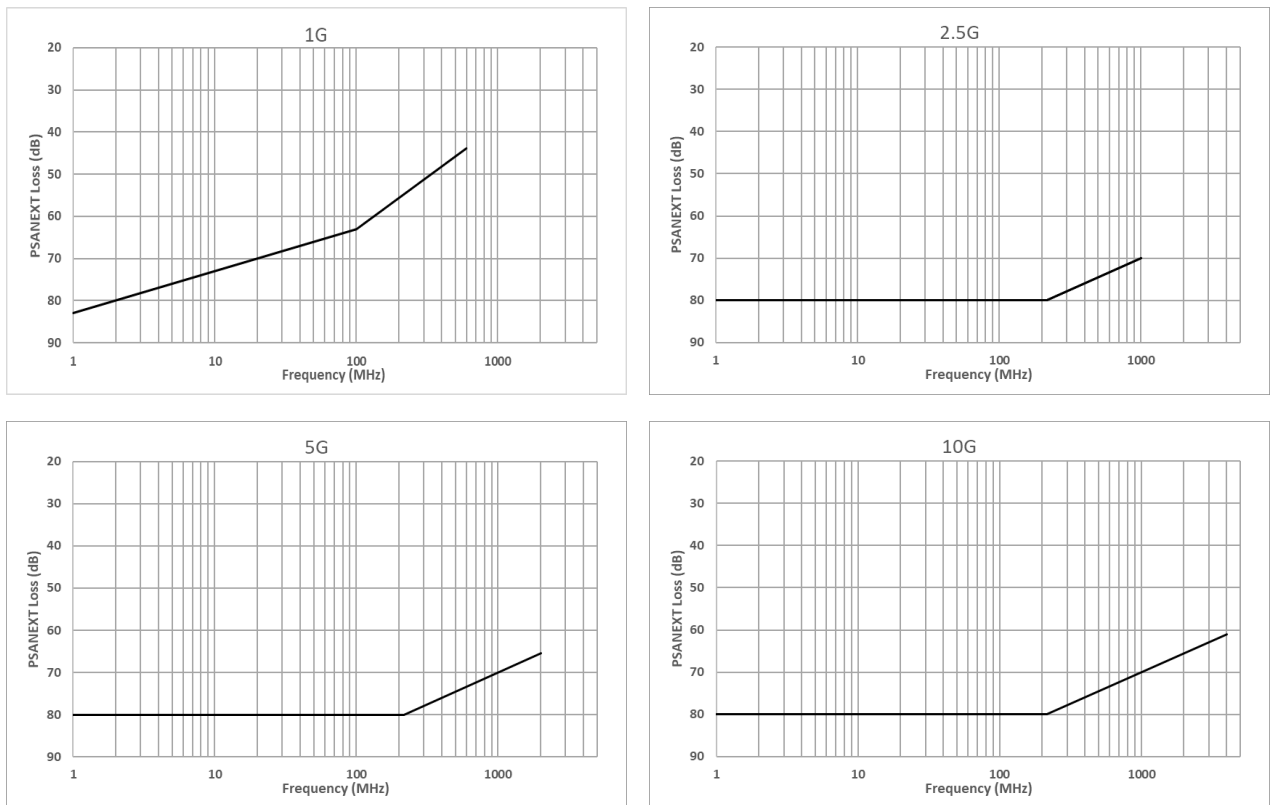

Figure 22: PSANEXT Loss requirements for multipoint measurement fixture cross talk

If the multipoint PCB connector contains other data ports than for 1G/2.5G/5G/10G Ethernet, e.g. for coaxial signalling, the fixture may include related traces and test ports to allow crosstalk measurements between the Ethernet ports and the other applications. The impedance of the fixture traces and test ports for these other applications shall match to the characteristic impedance of the corresponding multipoint connector port. If the other data port is single ended, i.e. a coaxial port, the single ended to differential S-parameter S_{dsxy} shall be used for calculating the PSANEXT Loss value. The limits in 5.2.4 may also be applied for the other data ports if no specific requirements are given by their application. If the multipoint connector contains other signals or pins that are excluded from the crosstalk measurement, it is recommended to terminate these pins with matching impedances to avoid resonances.

5.2.5 Cables

Measurement fixtures for cables shall allow to attach the conductors and the shield of a shielded cable directly to the fixture without the need for a connector. The measurement fixture shall contain a cable mounting apparatus that allows clamping or soldering the cable conductors and shield. An example of such a direct fixture is given in Figure 84.

Cable measurement fixtures for direct measurements shall fulfil RL, LCL and LCTL requirements in Table 15.

RL and LCL of direct cable measurement fixtures shall be measured with time domain gating while the LCTL is measured directly. The measurement setup is shown in Figure 23. A short piece of shielded cable is used to establish a Thru connection between the two fixtures. This cable shall be of the same type as the cable under test for the actual measurement as described in Chapter 6.2. Start and stop gate positions shall be set to accommodate the complete fixtures including the coaxial connections to the VNA test cable and a short piece of the cable under test. The gate positions for the RL and LCL measurements are determined by open fixture reflection coefficient (impulse response) measurements as illustrated in Figure 24. The fixtures are connected to the coaxial test cables of the VNA. The fixture terminals for attachment of the cable conductors

and cable shield are left open. The maximum position is defined as the time position where the time domain pulse response (reflection coefficient) of the S_{dd11} or S_{dd22} parameter respectively reaches its maximum value. The start position is calculated by subtracting 300 ps from the maximum position and the stop position is determined by adding 300 ps to the time position of the maximum. If the length of the fixture exceeds the equivalent signal reflection time of 300 ps between gate start and maximum, deviations from that default value may be done. In this case, the TDR response shall be documented to demonstrate that the gate positions are set correctly to accommodate the complete fixture including the coaxial connections to the VNA test cables.

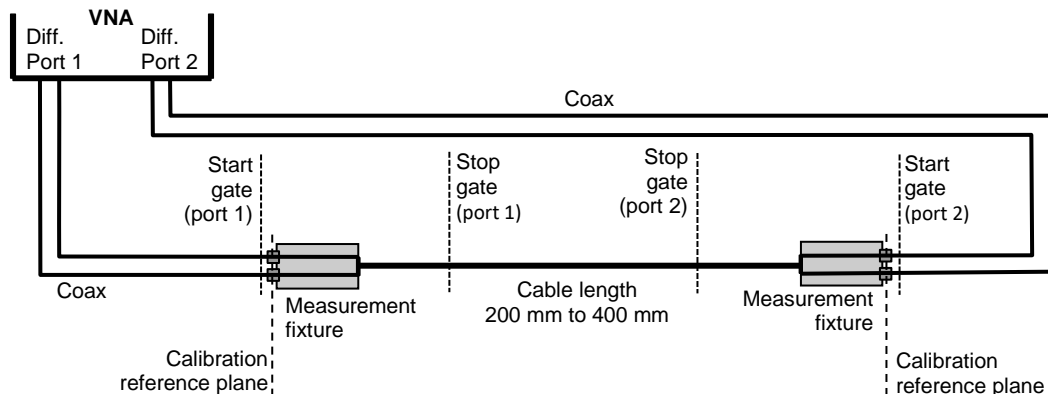

Figure 23: Measurement setup for direct cable measurement fixture characterization

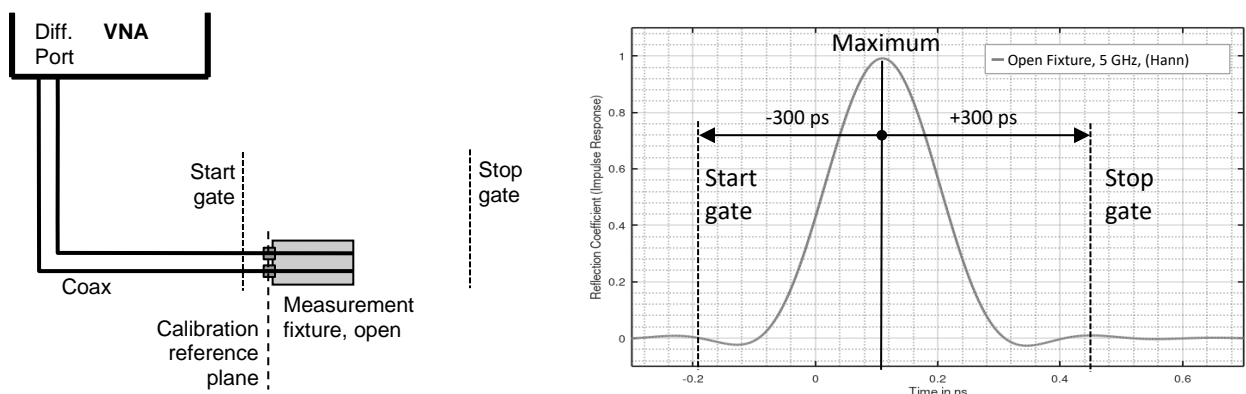

Figure 24: Definition of gate position for direct cable measurement fixture RL and LCL measurement and example of open test fixture reflection coefficient (impulse response) measurement for 10G

Table 15: Electrical requirements on cable measurement fixtures for direct measurement

Test Parameter	Symbol or related S-parameter	Speed grade	Requirement
RL	S_{dd11}, S_{dd22}	1G	$\geq 25 \text{ dB}$ $1 \leq f \leq 600$, frequency f in MHz
		2.5G	$\geq \begin{pmatrix} 25 & 1 \leq f < 10 \\ 25 + 8.6 \log_{10} \left(\frac{f}{10} \right) & 10 \leq f < 30 \\ 29 & 30 \leq f < 604 \\ 29 - 10 \log_{10} \left(\frac{f}{604} \right) & 604 \leq f \leq 1000 \end{pmatrix} \text{ dB}$ $1 \leq f \leq 1000$, frequency f in MHz

		5G	$\geq \begin{pmatrix} 25 & 1 \leq f < 10 \\ 25 + 8.6 \log_{10} \left(\frac{f}{10} \right) & 10 \leq f < 30 \\ 29 & 30 \leq f < 604 \\ 29 - 10 \log_{10} \left(\frac{f}{604} \right) & 604 \leq f \leq 2000 \end{pmatrix} dB$ $1 \leq f \leq 2000, \text{ frequency } f \text{ in MHz}$
		10G	$\geq \begin{pmatrix} 25 & 1 \leq f < 10 \\ 25 + 8.6 \log_{10} \left(\frac{f}{10} \right) & 10 \leq f < 30 \\ 29 & 30 \leq f < 604 \\ 29 - 10 \log_{10} \left(\frac{f}{604} \right) & 604 \leq f < 3000 \\ 22 & 3000 \leq f \leq 4000 \end{pmatrix} dB$ $1 \leq f \leq 4000, \text{ frequency } f \text{ in MHz}$
LCL, LCTL	S _{dc11} , S _{dc22} , S _{dc21}	1G	$\geq 25 \text{ dB}$ $1 \leq f \leq 600, \text{ frequency } f \text{ in MHz}$
		2.5G	$\geq 25 \text{ dB}$ $1 \leq f \leq 1000, \text{ frequency } f \text{ in MHz}$
		5G	$\geq 25 \text{ dB}$ $1 \leq f \leq 2000, \text{ frequency } f \text{ in MHz}$
		10G	$\geq 25 \text{ dB}$ $1 \leq f \leq 4000, \text{ frequency } f \text{ in MHz}$

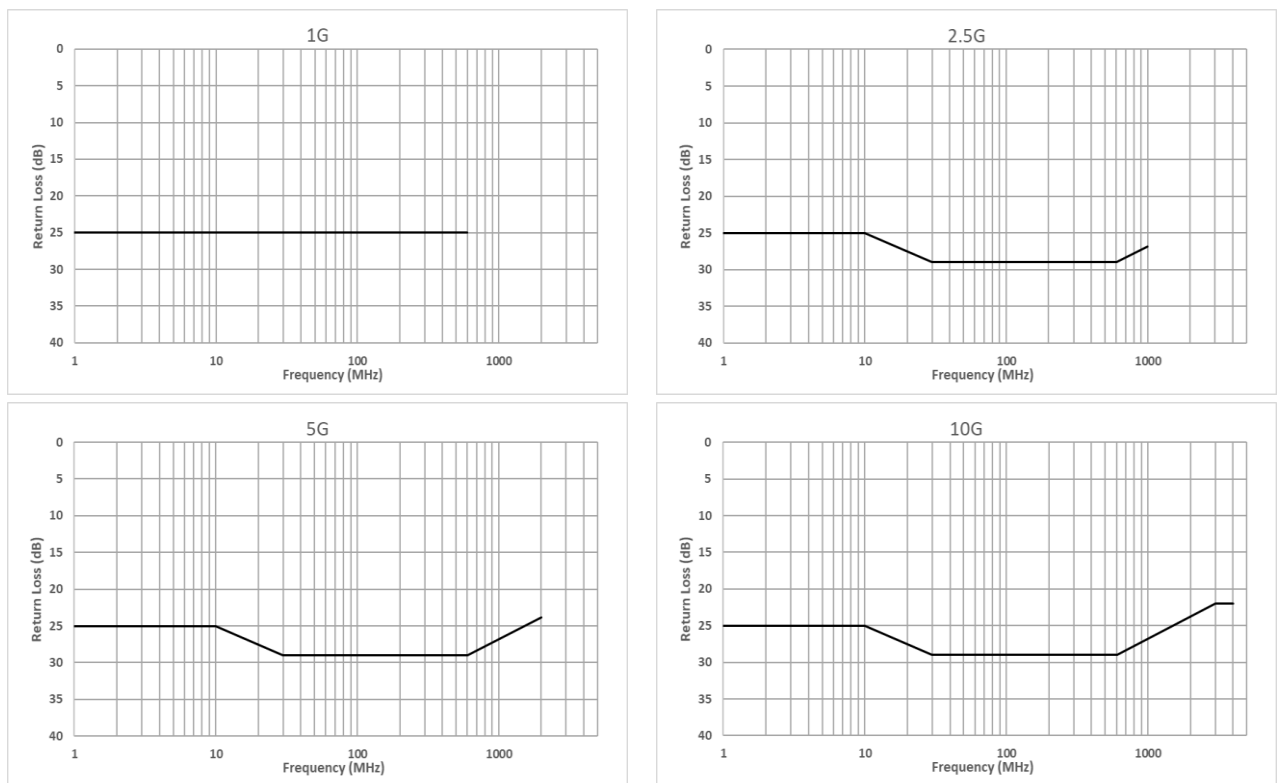

Figure 25: Return loss requirements for cable test fixtures, gated measurement

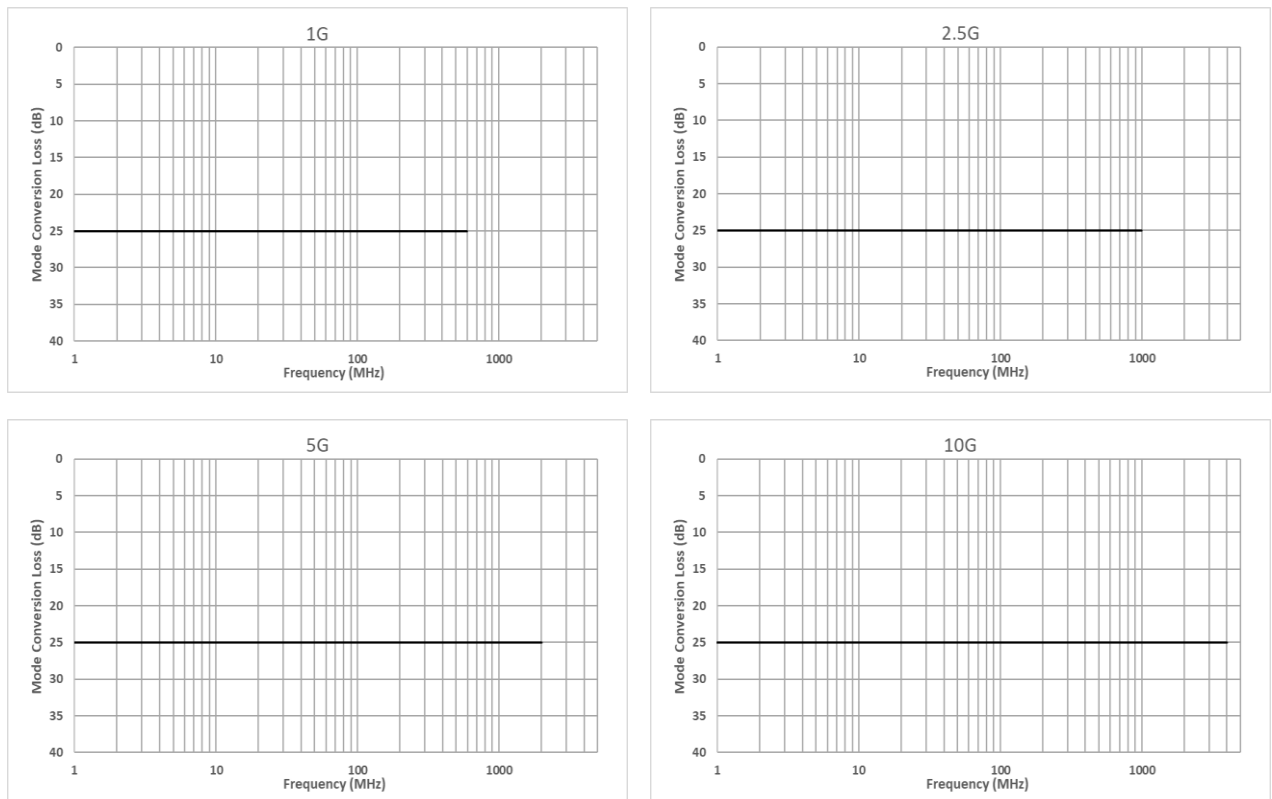

Figure 26: Balance requirements (LCL, LCTL) of cable measurement fixtures for direct measurement

5.3 Terminations for Triaxial Measurements

Screening and coupling attenuation measurements require termination loads within the test tube apparatus. For connector, cable assembly or channel measurements, termination loads may be socket or plug depending on the DUT. Unique numbers shall be assigned to the termination loads to allow individual identification. The termination resistors shall be suitable for RF applications in the frequency range under test.

The termination load shall have a $100\ \Omega$ nominal impedance in differential mode. The single ended impedance of the termination for every conductor of the differential pair shall be $50\ \Omega \pm 1\%$. The single ended terminations shall be matched against each other with a tolerance of $\pm 0.1\ \Omega$ at DC to provide low mode conversion. This circuitry results in a common mode termination impedance of $25\ \Omega$. A common and differential mode termination according to [6] can be used alternatively.

The termination shall be contained within a fully shielded enclosure (shielding cap) and not be exposed within the triaxial tube measurement area to minimize the influence of the termination circuit on the measurement result.

For cable measurements it is recommended to terminate each wire of the differential pair directly to the shield as shown in Figure 90. Alternatively, a PCB with termination resistors may be used to connect the cable conductors to the shield.

When measuring cable connectors or cable assemblies, ideally shielded terminations shall be used to minimize the influence of the termination on the connector measurement result.

When measuring PCB connectors, the whole PCB connector shall be exposed to the area under test up to where the PCB connector is mounted on the PCB surface. Soldering shall be identical to the recommendations of the connector supplier. The termination shall be at the foot of the connector within the shielding cap.

The same PCB connector with termination shall also be used when measuring a reference channel assembly.

Annex A.2 gives an example of a cable coupling attenuation measurement setup, including examples of a PCB connector under test and terminations.

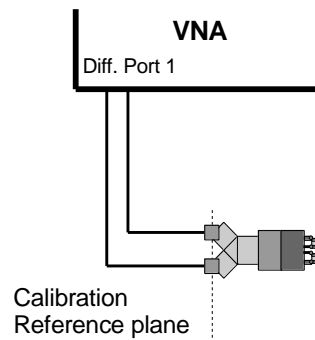

Figure 27: Validation of triaxial termination load

Termination loads shall fulfil the electrical requirements in Table 16 in the setup as shown in Figure 27.

Table 16: Return loss and balance requirements for termination loads for triaxial measurements

Test Parameter	Symbol or related S-parameter	Speed grade	Requirement
RL	S_{dd11}	1G	$\geq 20 \text{ dB}$ $1 \leq f \leq 600$, frequency f in MHz
		2.5G	$\geq 20 \text{ dB}$ $1 \leq f \leq 1000$, frequency f in MHz
		5G	$\geq 20 \text{ dB}$ $1 \leq f \leq 2000$, frequency f in MHz
		10G	$\geq 20 \text{ dB}$ $1 \leq f \leq 4000$, frequency f in MHz
LCL	S_{dc11}	1G	$\geq 22 \text{ dB}$ $1 \leq f \leq 600$, frequency f in MHz
		2.5G	$\geq 22 \text{ dB}$ $1 \leq f \leq 1000$, frequency f in MHz
		5G	$\geq 22 \text{ dB}$ $1 \leq f \leq 2000$, frequency f in MHz
		10G	$\geq 22 \text{ dB}$ $1 \leq f \leq 4000$, frequency f in MHz

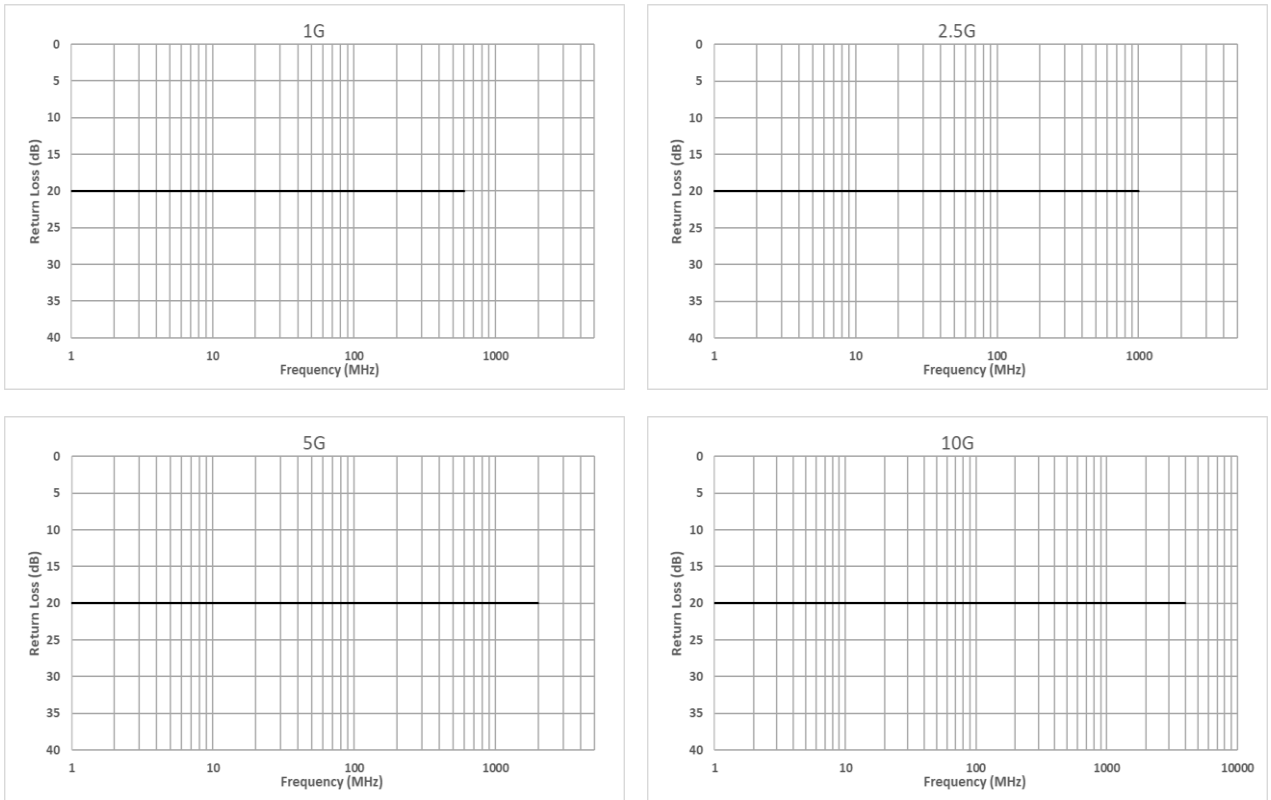

Figure 28: Return loss requirement for termination loads for triaxial measurements

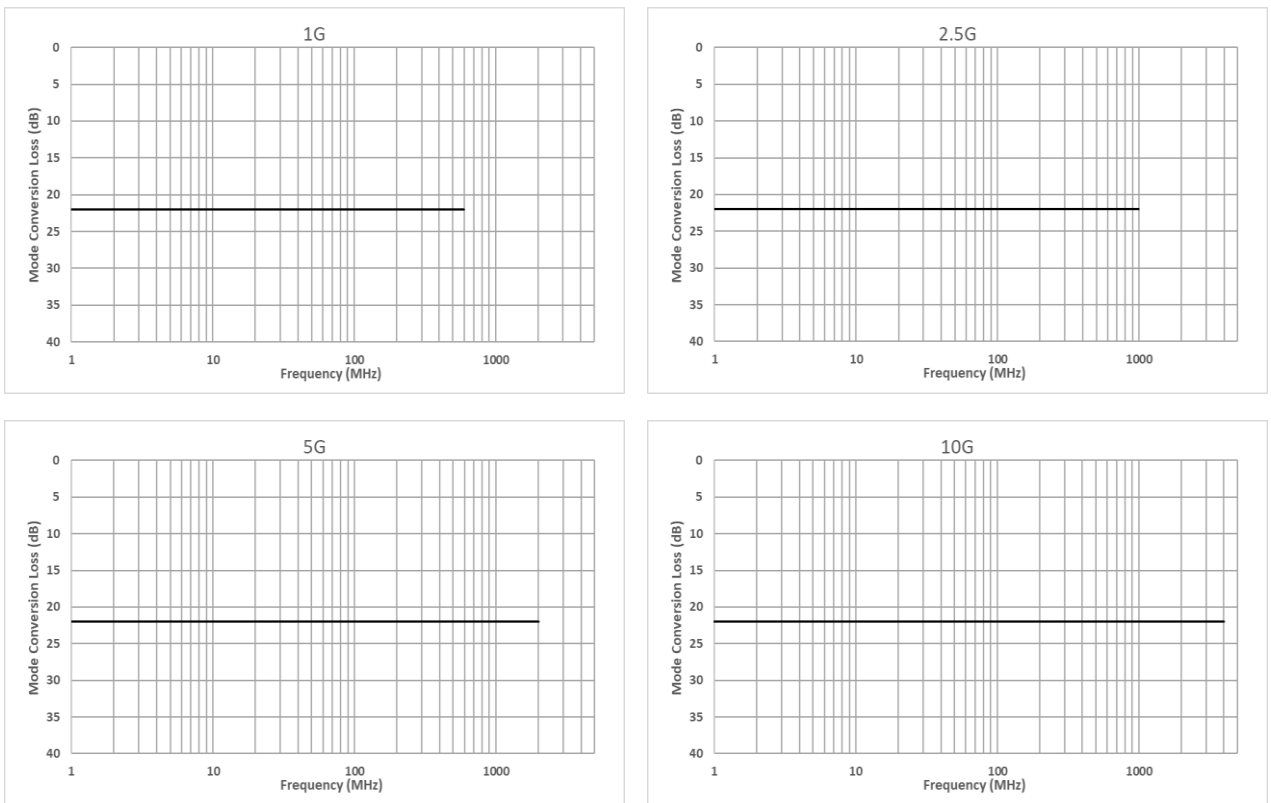

Figure 29: Balance requirement for termination loads for triaxial measurements

5.4 MDI Test Heads

Measurement fixtures as described in Chapter 5.2 may be used as MDI test head to perform S-parameter measurements as part of the ECU compliance test procedure. Further details on the ECU test procedure are specified in [11], [12] and [13]. When measuring into the open MDI test head it shall fulfill the balance requirement for LCL and CIDM of Table 17. The calibration reference plane is defined to be at the coax connectors of the MDI test head. A continuous low impedance ground connection from the ECU PCB connector shield to the outer contact of the measurement fixture coaxial connectors shall be provided.

If the ECU PCB connector is of multiport type, a suitable adaptation shall be provided so that a single port measurement fixture mechanically and electrically correctly mates with a multiport PCB connector at the MDI.

Figure 30 shows a basic concept of a measurement fixture used as MDI test head.

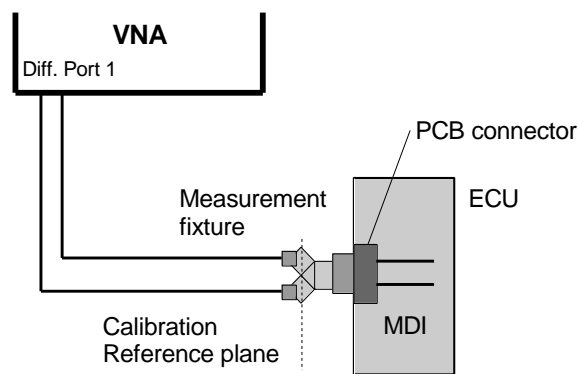

Figure 30: Example of MDI test head connected to the MDI

Table 17: Balance and impedance requirements MDI test heads

Test parameter	Symbol or related S-parameter	Speed grade	Requirement
CIDM	Z_{RF}	1G	$100 \Omega \pm 5 \Omega$ trace impedance (at 50 ps rise time round trip)
		2.5G	$100 \Omega \pm 3 \Omega$ trace impedance (at 50 ps rise time round trip)
		5G	$100 \Omega \pm 3 \Omega$ trace impedance (at 50 ps rise time round trip)
		10G	$100 \Omega \pm 3 \Omega$ trace impedance (at 50 ps rise time round trip)
LCL	S_{dc11}, S_{dc22}	1G	$\geq \begin{pmatrix} 56 & 10 \leq f \leq 50 \\ 81.2 - 14.83 \log_{10}(f) & 50 < f \leq 600 \end{pmatrix} dB$ $10 \leq f \leq 600$, frequency f in MHz
		2.5G	$\geq 30 dB$ $1 \leq f \leq 1000$, frequency f in MHz
		5G	$\geq 30 dB$ $1 \leq f \leq 2000$, frequency f in MHz
		10G	$\geq 30 dB$ $1 \leq f \leq 4000$, frequency f in MHz

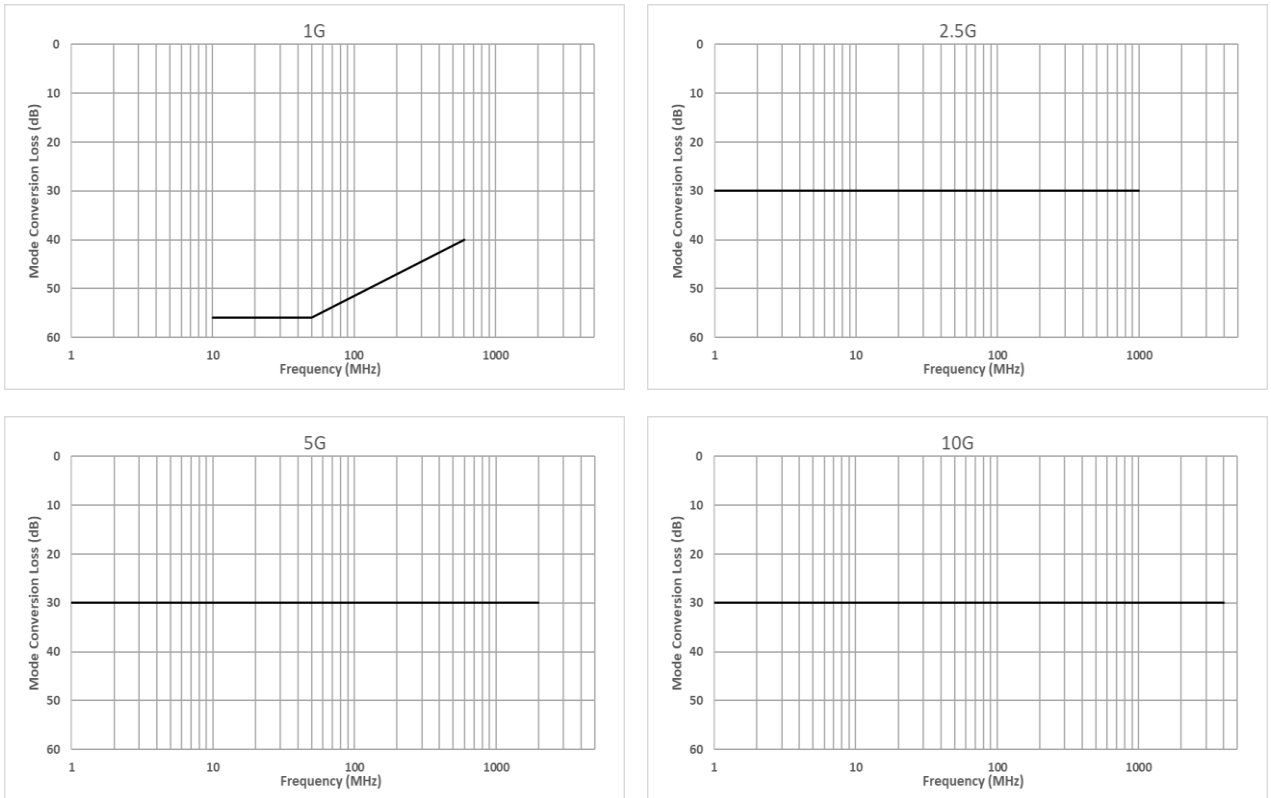

Figure 31: Balance requirements on MDI test heads

6 Measurement Setups

6.1 Measurement Setups for Connectors

6.1.1 Single Port and Multiport Connectors for SCC

Connectors are measured by the following methods:

Method A: Measurement of mated connector pairs using test cable assemblies and data postprocessing for connector de-embedding to remove the effects of cable assemblies, PCBs and measurement fixtures

Method B: Measurement of single connector components using connector measurement fixtures and data postprocessing for time gating to remove the effects of cables, PCBs and measurement fixtures

Connectors shall be either measured according to method A and fulfill the requirements in Table 18 or they shall be measured according to method B and fulfill the requirements in Table 19. The requirements for each method are defined in a way that allows to meet the link segment specifications in [1] and [2]. The used method may be chosen depending on the specific test cases in a connector qualification which is not in scope of this document.

Method A – Measurement of Mated Connector Pairs

Mated pairs of connectors shall be measured as part of cable assemblies, where measurement fixtures are attached to the opposite end of the cable assembly. The connectors shall be assembled as specified for the used connector/cable combination. The cable assembled to the cable connectors under test shall comply with the cable requirements in Table 20. PCB connectors are mounted directly onto the measurement fixture as specified for the individual component by the manufacturer. The measurement result is valid for the specific combination of socket and plug connector type.

Figure 32 shows the test setup to measure return loss and insertion loss of mated cable connectors and Figure 33 of the mated PCB connectors.

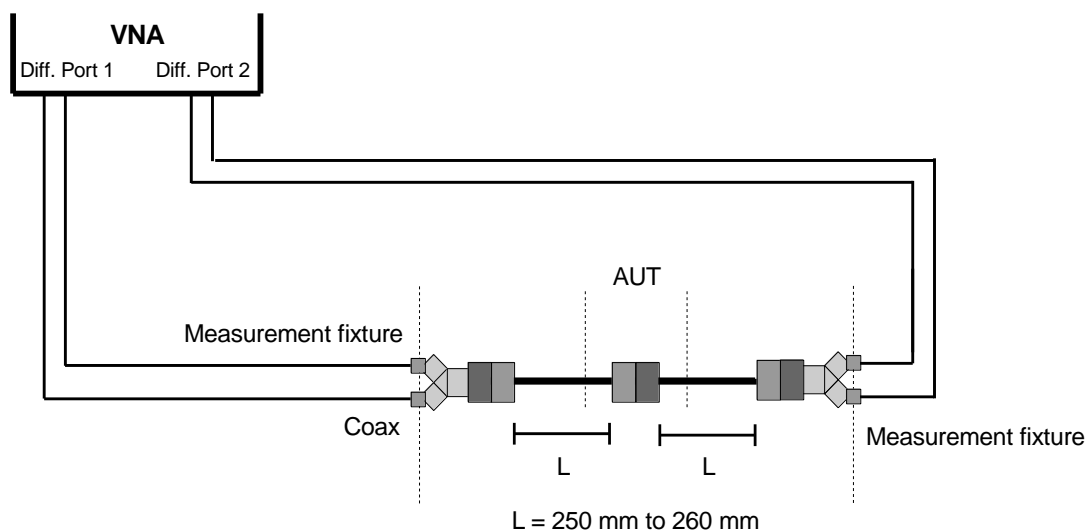

Figure 32: Mated cable connector pair measurement setup

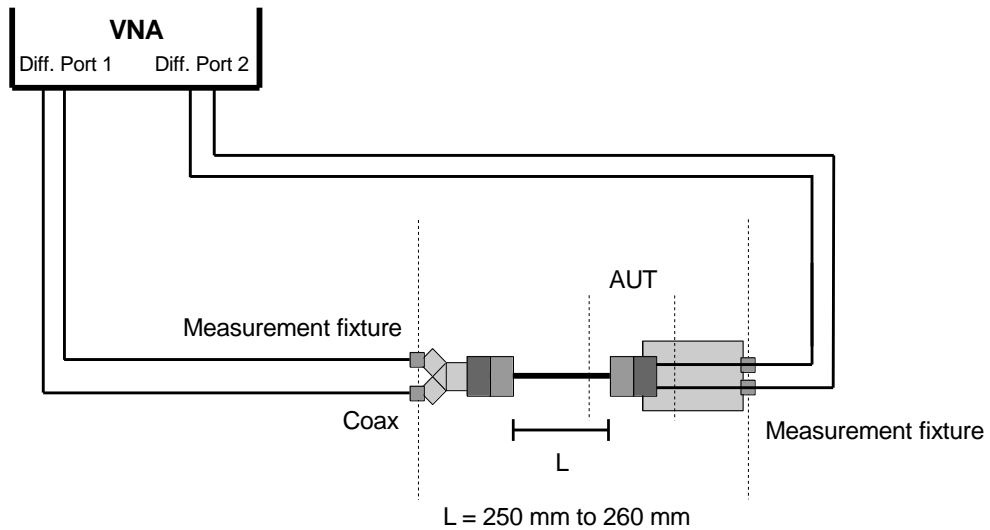

Figure 33: Mated PCB connector measurement setup

For measurements of mated connector pairs, internal de-embedding functions of the VNA or equivalent post processing software shall be used. The procedures shall be based on the impedance corrected 2X-Thru de-embedding method described in [9] or equivalent proprietary software. Recommended VNA settings for each speed grade are given in Table 4.

The function of de-embedding is to split the measured S-parameter set into different sections including the AUT and the sections before and after the AUT. The AUT shall cover the connector under test including the transition from contacts to the cable. Therefore, the 2X-Thru cable assembly as shown in Figure 34 shall be measured.

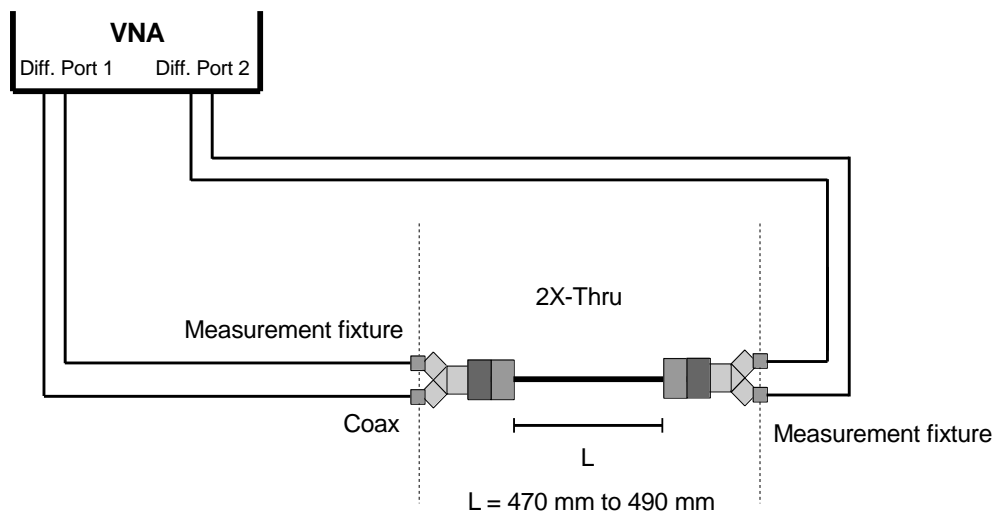

Figure 34: 2X-Thru cable assembly measurement setup

The 2X-Thru cable assembly shall have a cable length of 470 mm to 490 mm. Since the length of the 2X-Thru cable assembly defines the reference planes for the de-embedding process, this ensures that the mated connector under test includes approximately 10 mm homogeneous cable length on each side of the connector.

To minimize the deviations between 2X-Thru measurement and actual connector measurement, connectors of the same type and cable type, preferably from the same production lot shall be used. The cable assembly lengths in Figure 32, Figure 33 and Figure 34 shall be used for RF conformance tests to ensure comparability of results. Deviations from these lengths can be done for comparison tests in test sequences, e.g. before and after environmental exposure, if the specific test standards require different lengths.

For PCB connector measurements a S-parameter set of a pair of PCB 2X-Thru lines shall be measured (Figure 35), that has twice the length of the traces from the coaxial connector to the PCB connector footprint. The traces shall have the same configuration and orientation as the ones going to the PCB connector under test. The trace length is calculated up to the point where the homogeneous traces from the coaxial connectors to the PCB connector end and a specific layout related to the PCB connector starts. Optimized PCB connector layout or any kind of compensation on the layout shall be excluded from the PCB thru line measurement.

The mated connector pair under test shall comply with the specified propagation delay, return loss and insertion loss in Table 18. To check the consistency of the de-embedding process the test procedure described in Chapter 4.4 shall be applied to the measurement data of the 2X-Thru structures.

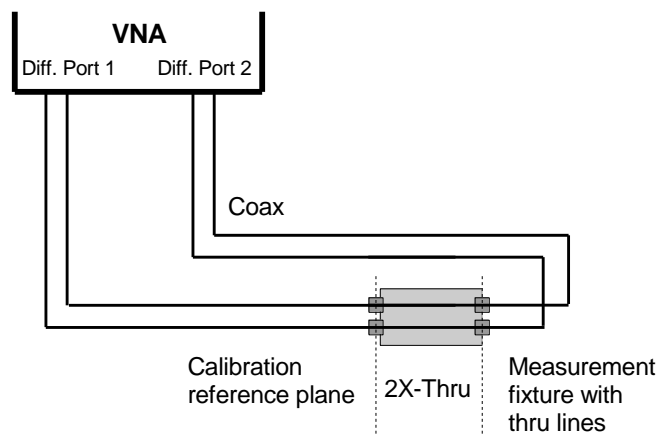

Figure 35: PCB measurement fixture 2X-Thru measurement setup

Method B – Measurement of Single Connector Components

Single connector components are measured against a measurement fixture. For cable connectors this allows capturing the properties of the connector including the wire transition from contacts to the cable. The transition shall be part of the measurement result. The connector shall be assembled as specified for the connector/cable combination. The cable assembled to the cable connector under test shall comply with the cable requirements in Table 20. The other side of the cable assembly shall be terminated and alternatively may be left open, if the Open is sufficiently far away from the evaluation window that the measurement result is unambiguous.

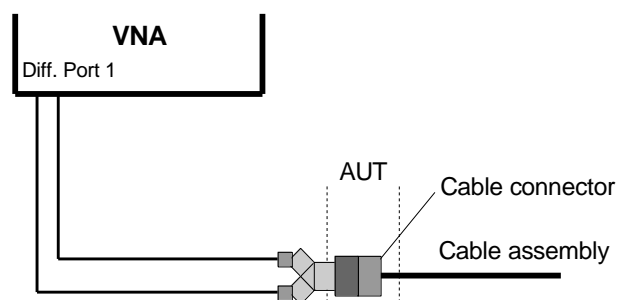

Figure 36: Measurement setup for cable connector return loss measurements

The measurement of PCB connectors shall include the transition from the PCB to the connector. It is recommended, that the layout is optimized for the specific PCB connector type under test, but the implementation shall be technically feasible with standard processes and representative for typical automotive applications. The coaxial ports of the PCB connector measurement fixture shall be terminated with a matched pair of termination loads or by termination into the calibrated differential port 2 of the VNA.

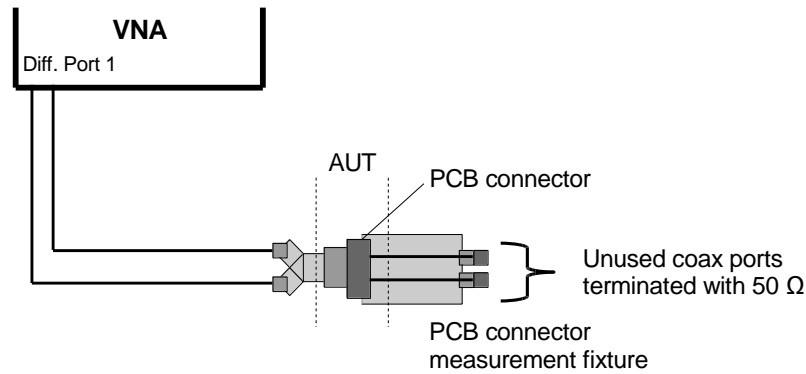

Figure 37: Measurement setup for PCB connector return loss measurements

Connectors shall be measured using gating function. The start and stop positions of the gates are determined by means of a reflection coefficient (impulse response) measurement with the bandwidth of the speed grade.

The measurement fixture connected to differential port 1 shall be left open, not mating with its counterpart measurement fixture. The maximum position of the reflection coefficient shall be identified as the position, where the measured reflected impulse response on differential port 1 reaches its local maximum. The start gate position shall be calculated as maximum position -200 ps. The stop gate position shall be maximum position +300 ps (Figure 38).

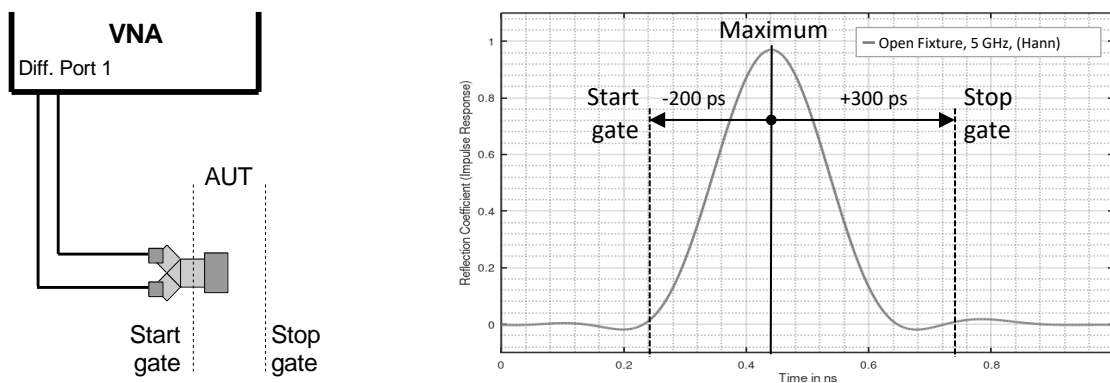

Figure 38: Measurement setup to determine the positions of start and stop gate for connector return loss measurements and example of open test fixture reflection coefficient (impulse response) measurement for 10G

Start and stop gate positions shall be set to accommodate the complete DUT and exclude the coaxial connectors of measurement fixtures. If the defined default gate positions are not suitable for the electrical length of the DUT or fixture, deviations from the default values may be done. Deviations shall be documented including TDR response, that gives evidence, that the gate positions are set close to the beginning and end of the DUT. When the gates are set, the measurement fixture is mated with the DUT to be measured.

With multiport connectors, each port shall be measured, but measurements may be carried out on each port separately if the VNA doesn't have enough measurement ports to connect to all ports at the same time. Unused ports of multiport PCB connectors may be left open on the cable side and shall be terminated on PCB side. Unused ports of mated multiport cable connectors (inline connectors) shall be terminated using short cable assemblies on at least one side. Examples for such short cable assemblies with termination are shown in Figure 39 and Figure 40 on the cable plug sides.

The connector shall comply with the requirements in Table 19.

6.1.2 Connector Setups for ES - Crosstalk

Multiport connectors shall be measured like single port connectors as described in Chapter 6.1.1 for each port intended to be used for 1G/2.5G/5G/10G. The defined stop gate position with +300 ps also allows measuring longer and shorter contact rows in angled PCB connectors without the need to relocate the gate positions. However, if a connector is electrically longer or the measurement fixtures traces are too short to exclude the coaxial connectors from the measurement result, the gate positions may be adjusted to correctly cover the DUT. Deviations from the default value need to be documented.

In addition, crosstalk within multiport connectors shall be measured. The multiport PCB connector measurement fixtures shall fulfill the requirements in Chapters 5.2.3 and 5.2.4. The multiport PCB connectors are mounted directly on the measurement fixture as specified by the component manufacturer. Ports of the measurement fixture that are not connected to the VNA shall be terminated with 50 Ω. The ports of the multiport connector on cable side shall be connected to single port measurement fixtures via cable assemblies with a nominal cable length of 250 mm. The ports of these measurement fixtures that are not connected to the VNA shall be terminated with 50 Ω.

Figure 39 shows the setup for multiport PCB connector AFEXT Loss crosstalk measurements. Differential port 1 of the VNA is connected to the coaxial ports of individual single port measurement fixtures at the far end side. Differential port 2 of the VNA is connected to the coaxial ports of the measurement fixture of the multiport PCB connector under test.

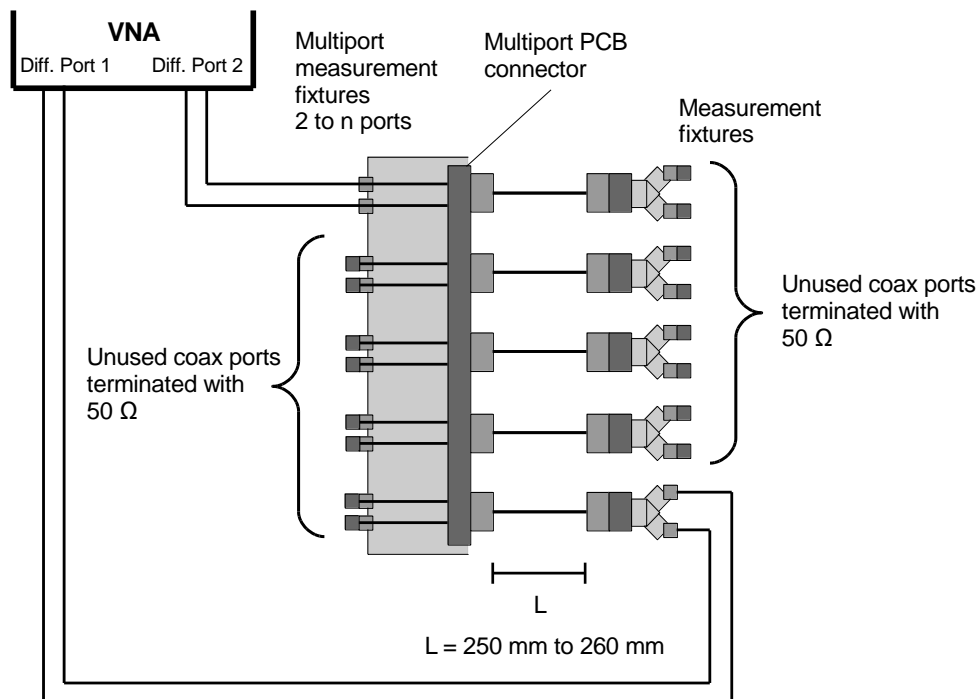

Figure 39: Multiport PCB connector measurement setup for AFEXT Loss

Figure 40 shows the measurement setup for multiport PCB connector ANEXT Loss crosstalk measurements. Differential ports 1 and 2 of the VNA are connected to the coaxial ports of the measurement fixture of the multiport PCB connector under test. The cable side of the DUT is terminated via individual measurement fixtures.

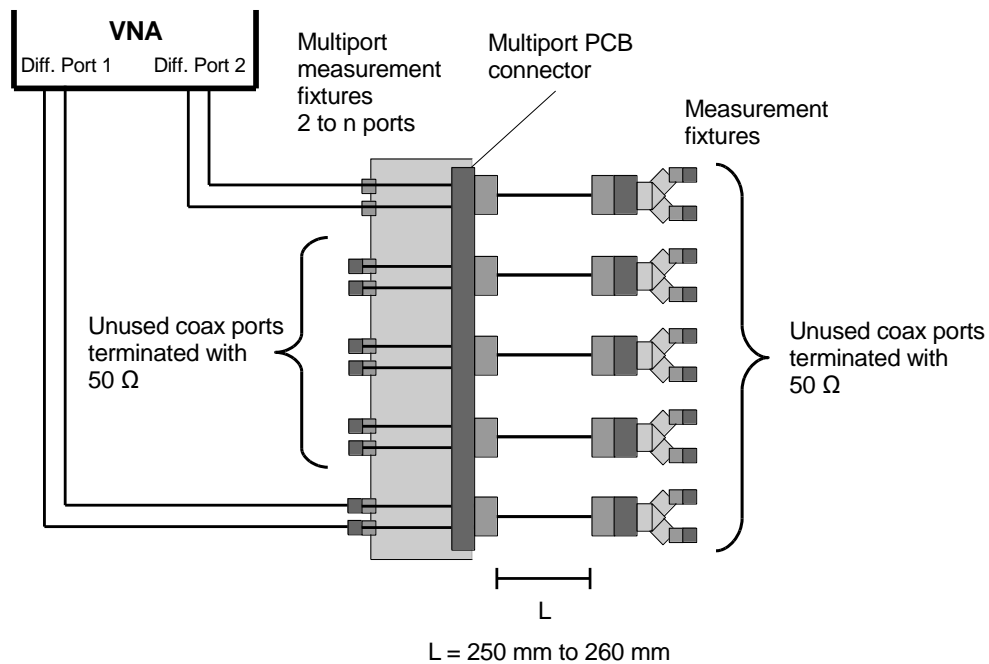

Figure 40: Multiport PCB connector measurement setup for ANEXT Loss

Each port shall comply with the specified alien crosstalk requirements in Table 23.

If the multiport connector contains other data ports than for 1G/2.5G/5G/10G Ethernet, e.g. for coaxial signaling, ANEXT Loss and AFEXT Loss between the Ethernet ports and ports for other applications may be measured in addition. In this case, the measurement fixture for the PCB connector shall provide related traces and test ports as described in Section 5.2.4. The cable side of these connector ports shall be connected to single port fixtures designed for the corresponding application. Unused ports shall be terminated with the nominal impedance of the application. If the data port is single ended, i.e. a coaxial port, the corresponding single ended to differential S-parameter S_{dsxy} shall be used for calculating the ANEXT Loss and AFEXT Loss values. The limits in Table 23 may also be applied for the data ports other than 1G/2.5G/5G/10G Ethernet if no specific requirements are given by their application.

6.1.3 Connector Setups for ES – Coupling and Screening Attenuation

Balance, coupling attenuation and screening attenuation are the main parameters for balanced systems defining the EMC properties apart from internal crosstalk. The coupling and screening attenuation of PCB and in-line connectors are measured by means of the triaxial tube in tube method as described in [5]. The upper and lower frequency of the test setup is limited by the dimensions of the tube, the electrical length of the DUT and other factors. These limitations need to be disclosed and agreed on between client and measurement service provider.

3-port measurement setup using VNA without balun shall be used. The differential port of the VNA acts as generator and the single ended port as receiver. To measure coupling attenuation, differential port 1 shall be operated in differential mode. To measure screening attenuation, differential port 1 shall be operated in common mode.

The length of the cable assembly shall be between 775 mm and 825 mm. As the length of one segment of tube for tube in tube measurements typically is 500 mm long this allows easy handling while keeping the influence of the cable on insertion loss and balance low. With respect to these dimensions, the use of a triaxial tube with nominal length 500 mm is implied.

The connection points from the inner tube to the cable shield and from the cable shield to the termination shall be directly after the connector (≤ 30 mm) to include the transition from the connector to the cable to the measurement while keeping the overall cable length exposed within the measurement small.

The connector under test shall be aligned concentrically along the longitudinal axis of its mated connector counterpart to avoid unduly mechanical stress onto the connector. Making use of the allowed exposed cable length of up to 30 mm may provide axial clearance to accommodate slight misalignment.

The cable used for connector coupling and screening attenuation measurements shall fulfill the electrical requirements for cables as specified in Table 24.

Figure 41 shows the measurement setup for cable connectors. To minimize the influence of the termination, the mated connector containing the termination shall be ideally shielded with 360° contact to a shielding cap as shown in Figure 43 and Figure 44.

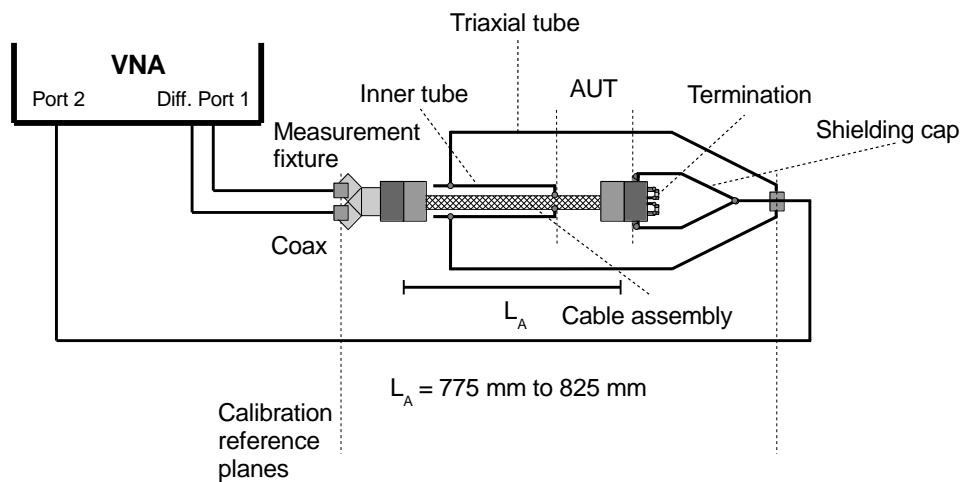

Figure 41: Cable connector measurement setup for coupling and screening attenuation

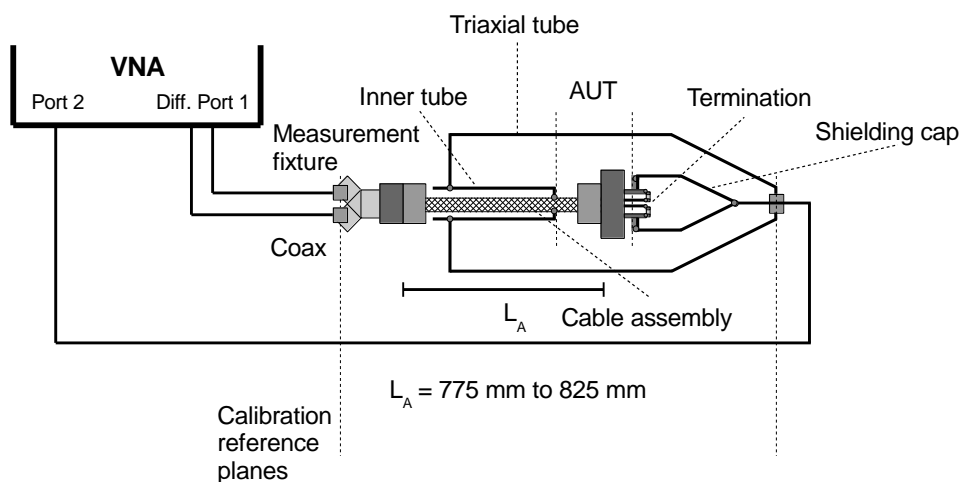

Figure 42: PCB connector measurement setup for coupling and screening attenuation

The area under test for PCB connectors includes the mated connector and its cable side counterpart. Also included is the transition from the connector housing to the shielding cap of the termination, as the

transition from the connector housing to the PCB is characteristic for the shielding of component and part result of the connector design.

For PCB connectors that provide additional shield contact from the connector housing to a shielded enclosure, the reference plane at the PCB connector side may be set at the point, where the EMC seal is attached. The unmodified EMC seal as supplied by the manufacturer shall be used for measurement. In this case, the connector housing and the transition to the PCB is not part of the measurement but shall be located within the shield cap referenced in Figure 43 and Figure 44.

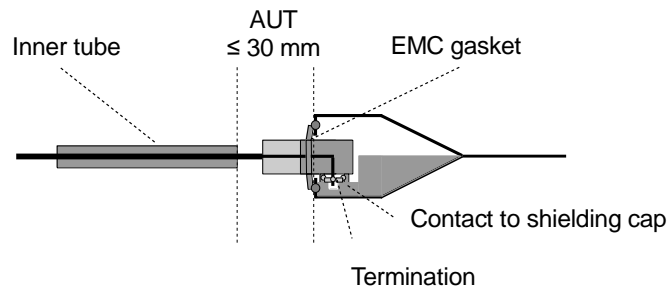

Figure 43: Definition of termination for single-port connectors with EMC gasket cable connector measurement termination

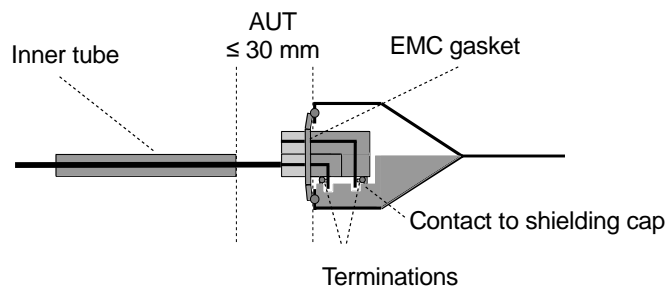

Figure 44: Definition of termination for multipoint connectors with EMC gasket or as cable connector measurement termination

With multipoint connectors, the coupling and screening attenuation of one port per row shall be measured. Especially for angled connectors, the length of the data and screening contacts is different between upper and lower row, which may affect the coupling and screening attenuation. It is assumed that the shielding properties of each port in one row is comparable. If the ports within one row differ in design substantially, each port shall be measured. Unused ports shall be terminated on PCB side and left open at the cable connector side, expecting that the crosstalk between the pairs has only got a minor influence on the coupling and screening attenuation measurement results (Figure 46).

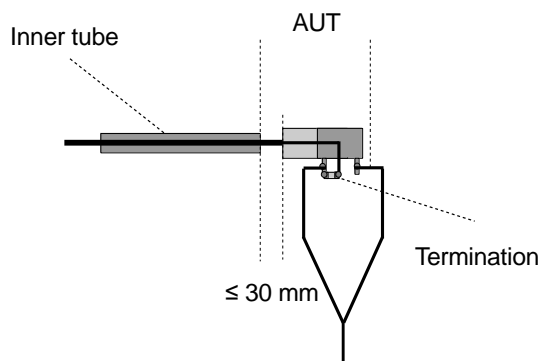

Figure 45: Definition of single-port PCB connector AUT for coupling and screening attenuation

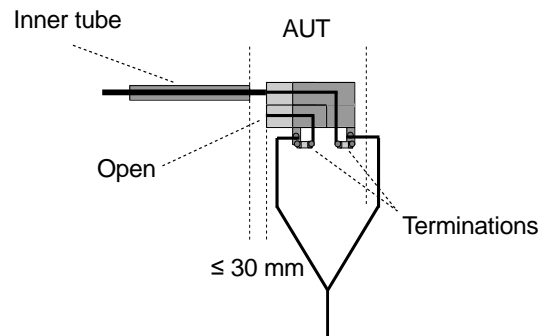

Figure 46: Definition of multiport PCB connector AUT for coupling and screening attenuation

The correction methods for a_c and a_s as described in 3.8 shall be applied to the VNA measurement results. The connector shall comply with the coupling and screening attenuation requirements in Table 24.

6.2 Measurement Setups for Cables

6.2.1 Cable Setup for SCC

SCC parameters of cables shall be measured by means of VNA or equivalent time-domain-based equipment in a differential two port measurement setup as shown in Figure 47. The minimum bending radius of the DUT and coaxial test cables shall be maintained. The DUT length for direct cable measurements shall be 10 m. The DUT length for de-embedded measurements shall be 10.2 m. Typically cable measurements are carried out on single cables without connectors attached.

The cable measurement fixtures for direct measurement including the cable transition area shall fulfill the electrical requirements in Chapter 5.2.5. The correct attachment of the cable under test to the fixture terminals shall be verified by additional measurement of the time domain gated fixture RL and LCL with the same fixture characterization procedure as described in Chapter 5.2.5. The gate positions shall be the same as determined during this characterization. This additional fixture verification measurement can be done simultaneously with the actual measurement of the cable under test, e.g. in separate trace windows. Thus, no additional measurement time would be needed. The time domain gated fixture RL and LCL verification measurements shall meet the requirements in Table 15.

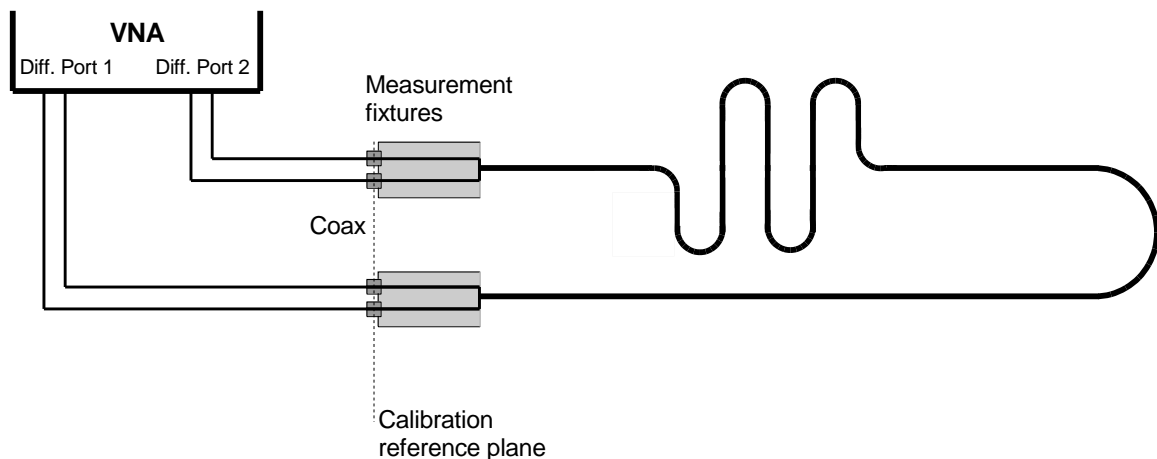

Figure 47: VNA measurement setup for direct measurement of cables

As alternative to the direct measurement of cables as shown in Figure 47, de-embedding may be applied to remove the measurement fixtures from the measurement result. Cable measurement de-embedding uses a 2X-Thru as shown in Figure 48. The measured S-parameters are split in the middle of the 2X-Thru during the de-embedding process into two S-parameter sets, assuming approximately identical electrical length of both measurement fixtures. If impedance controlled de-embedding tools are used, the S-parameter sets are used by the de-embedding software to generate the fixture models from the FIX-DUT-FIX measurement.

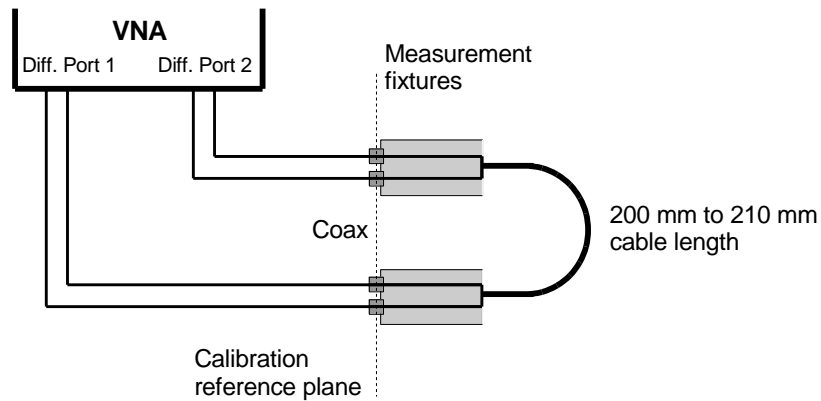

Figure 48: 2X-Thru VNA measurement setup for de-embedded measurement of cables

Figure 49 shows the FIX-DUT-FIX setup for the de-embedding measurement. The tool de-embeds the AUT using the information from the 2X-Thru. As the DUT length for de-embedded measurements is 10.2 m, no further correction is required the DUT length after de-embedding equals nominal 10 m.

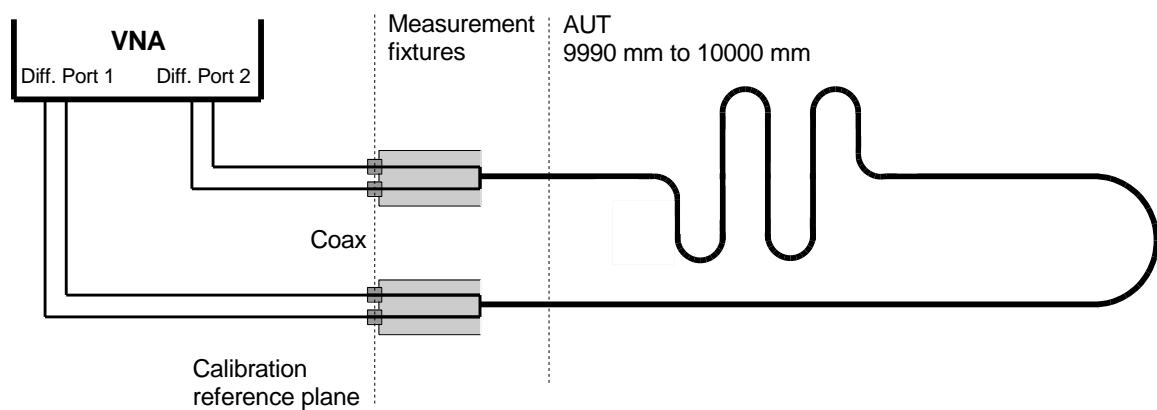

Figure 49: DUT VNA measurement setup for de-embedded measurement of cables

TDR impedance measurements may be carried out in a one port setup from both sides sequentially as shown in Figure 50, with the far end measurement fixture terminated into termination loads or into a differential port of the measurement instrument. The far end of the DUT may also be left open to ease handling if it is made sure that the results are unambiguous and not falsified by reflections at the open end of the DUT. Recommended parameters for using a VNA to perform impedance measurements are given in Table 7. The defined rise time may be applied by software filtering of the reflected signal within the TDR scope.

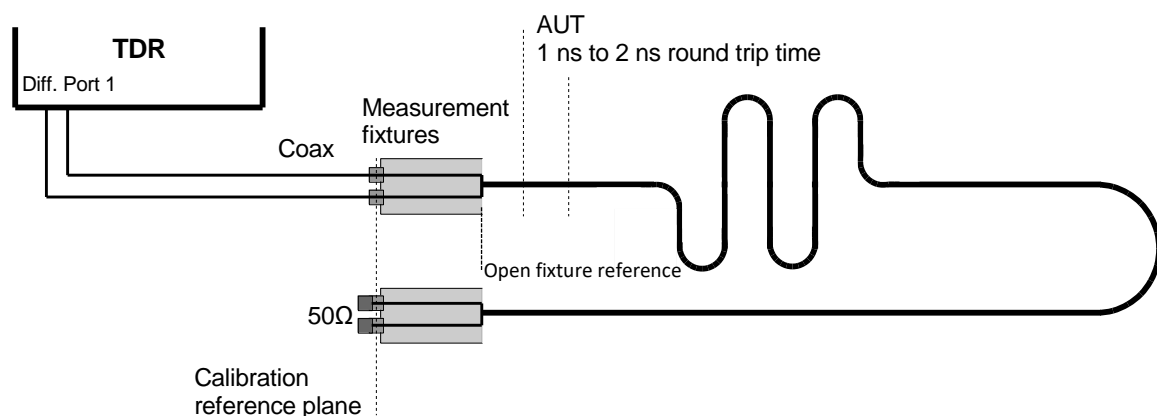

Figure 50: TDR measurement setup for cables

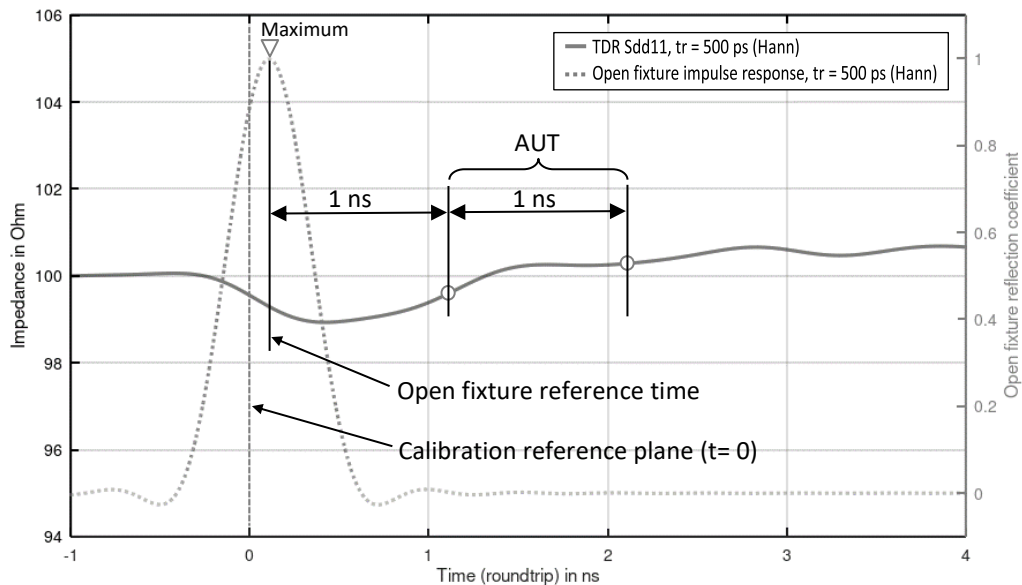

Figure 51: Example TDR measurement with definition of evaluation window for CIDM limit

CIDM shall be measured within the area under test from 1 ns to 2 ns round trip time measured from the open fixture reference time. The open fixture reference time shall be measured with the DUT not connected, where the impulse response for the defined rise time reaches its maximum.

Cables shall fulfill the requirements in Table 20.

6.2.2 Cable Setup for ES – Coupling and Screening Attenuation

The coupling attenuation, screening attenuation and balance are the main parameter for STP channels defining the EMC properties apart from internal crosstalk. Coupling and screening attenuation are also directly related to alien crosstalk from and to other cables within a wiring harness. This applies to crosstalk from differential and single ended interference sources.

The coupling and screening attenuation of cables is measured by means of the triaxial tube method as described in [6].

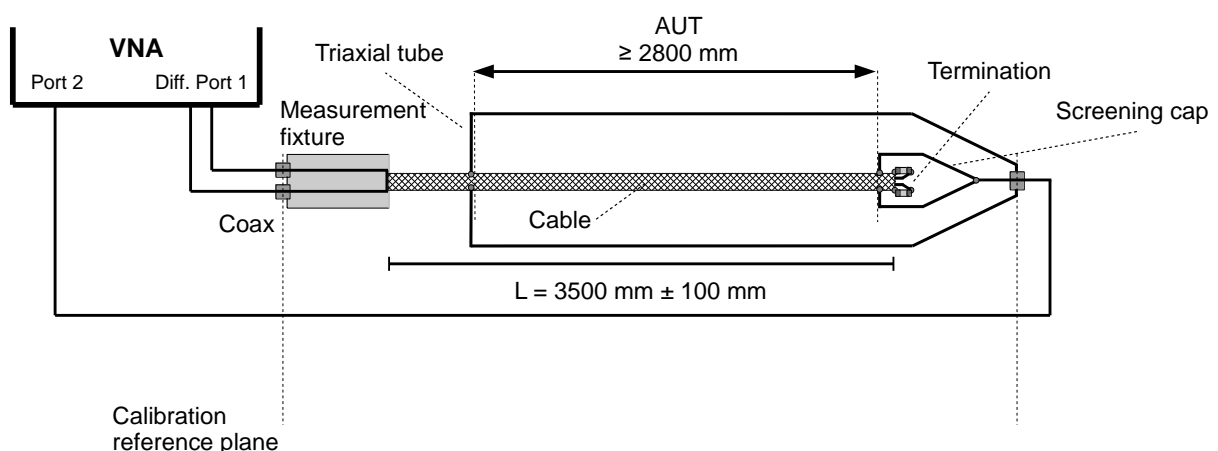

Figure 52: Cable measurement setup for coupling and screening attenuation

3-port measurement setup using VNA without balun shall be used. The differential port of the VNA acts as generator and the single ended port as receiver. To measure coupling attenuation, differential port 1 shall be operated in differential mode. To measure screening attenuation, differential port 1 shall be operated in common mode.

The overall length of the cable under test shall be between 3400 mm and 3600 mm. The exposed cable length within the triaxial tube shall be at least 2800 mm. With respect to the dimensions of the cable under test, the use of a triaxial tube with nominal length 3 m is implied.

The correction methods for a_c and a_s as described in 3.8 shall be applied to the VNA measurement results. The cable shall comply with the coupling and screening attenuation requirements in Table 24.

6.3 Measurement Setups for Cable Assemblies and Channels

6.3.1 General Remarks on Cable Assembly and Channel Measurements

The basic methodology for measuring complete channels and cable assemblies is similar. Therefore, both topics are described jointly in this chapter. Measuring of crosstalk parameters is not applicable for cable assemblies. The minimum bending radius of the DUT and coaxial test cables shall be maintained.

If a communication channel consists only of one cable assembly, the electrical requirements for the whole communication channel (SCC context) according to Table 22 shall apply, apart from the return loss requirements, which shall fulfill the return loss requirements for cable assemblies (SCC context) with attached connectors of Table 21.

Communication channel RL up to a few hundred MHz is dominated by cable impedance and the variations from one segment to the others. Even with the tightly specified cable impedance of $100 \Omega \pm 3 \%$, violations of the WCC SCC RL requirement by a few dB may occur. Further tightening of cable impedance requirements was seen as not feasible due to technical and economic reasons.

6.3.2 Cable Assembly and Channel Setups for SCC

SCC parameters of cable assemblies and communication channels shall be measured by means of VNA or equivalent time-domain-based equipment. Measurements are carried out on standalone DUTs. However, the electrical requirements for the SCC shall also be met within the context of an environment system, e.g. a wiring harness.

To allow comparing the electrical properties of components from different suppliers and comparing the measurement results of different test houses, Annex B.1 defines reference cable assemblies and Annex B.2 defines a reference communication channels.

The measurement setup for cable assemblies and channels for SCC is shown in Figure 53. Measurements shall be carried out using direct or de-embedded measurement. If direct measurements are performed, the measurement fixtures shall fulfill the electrical requirements in Chapter 5.2.1. If de-embedded measurements are performed, the 2X-Thru in relation to the DUT shall fulfill the requirements in 5.1.

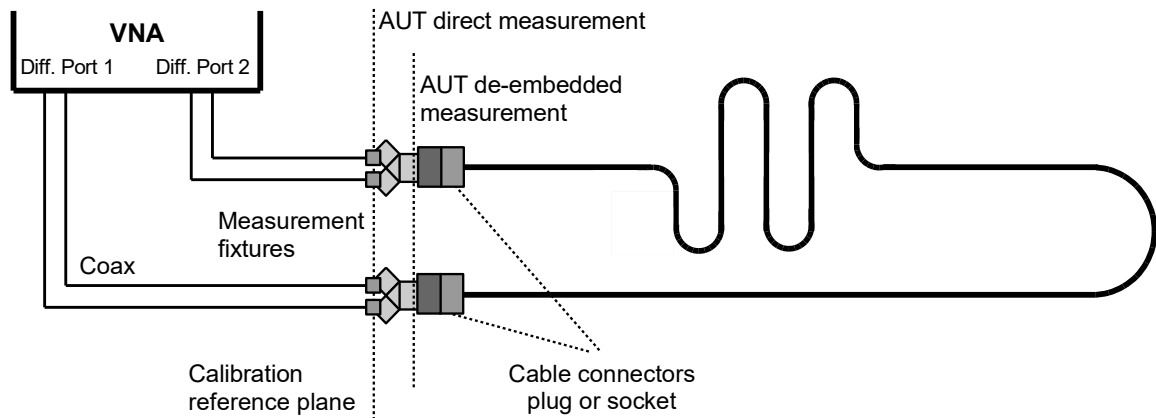

Figure 53: VNA measurement setup for cable assemblies

The insertion loss is defined as informative parameter only, as it depends on the cable assembly length and the cable type. The cable assembly shall fulfill the electrical requirements in Table 21.

Figure 54 shows the measurement setup for communication channels. A communication channel may contain up to five cable assemblies.

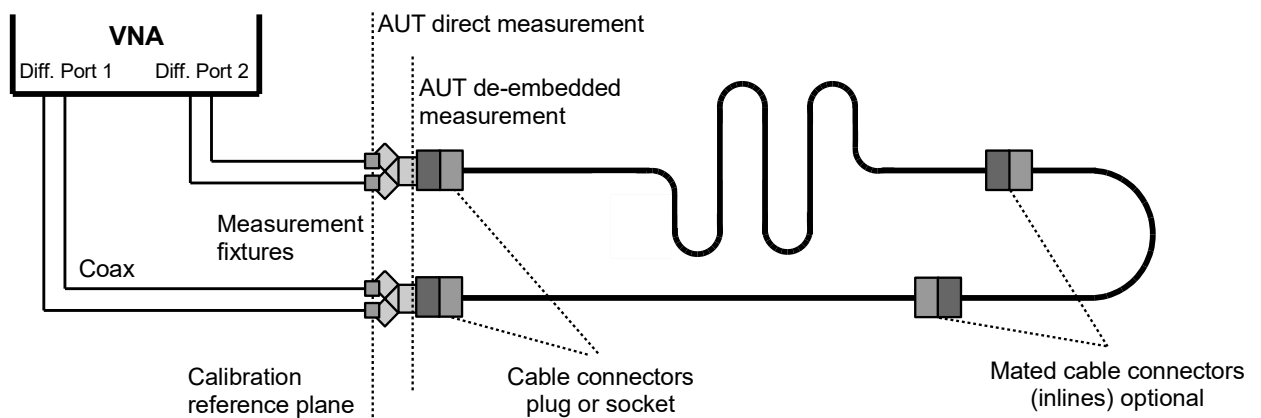

Figure 54: VNA measurement setup for communication channels

The communication channel shall fulfill the requirements in Table 22.

6.3.3 Cable Assembly Setup for ES – Coupling and Screening Attenuation

Decoupling within the context of whole communication channels in the environment system is ensured by meeting the coupling attenuation requirements for connectors (Table 23) and cables (Table 24). To make sure that cable assemblies have compliant shielding properties, the reference cable assembly RCA1 as shown in Annex B.1 shall be measured. With respect to the dimensions of the cable assembly, the use of a tube with nominal length 3 m is implied.

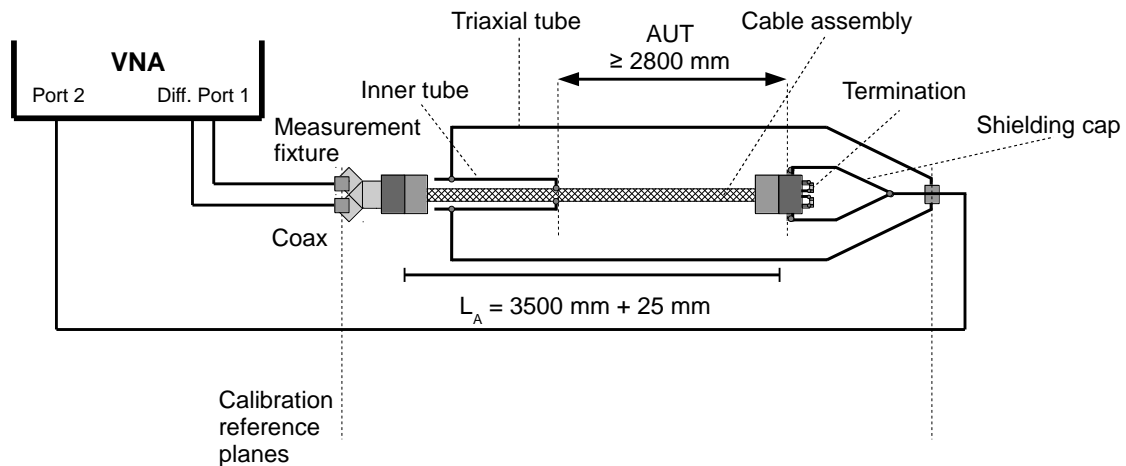

Figure 55: Coupling and screening attenuation reference cable assembly

The cable connector inside the test tube can be either a receptacle or a pin terminal as typically used in inline connectors. This connector shall be mated to a counterpart that is terminated within a shielded containment inside the test tube. Objective of this test is to demonstrate a compliant cable shield termination in the connectors of a cable assembly. For that reason, a complete shielding of the mating counterpart and direct connection of the counterpart's shield contacts to the shielded containment is recommended. EMC gaskets may be used depending on the specific design.

The correction methods for a_c and a_s as described in 3.8 shall be applied to the VNA measurement results. The cable assembly shall comply with the coupling and screening attenuation requirements in Table 25.

6.3.4 Whole Communication Channel Setup for ES – Crosstalk

The relevant coupling parameter of whole communication channels in the environment system is the differential crosstalk to neighbor wires in a bundle of cables, that is a meaningful representation of a wiring harness as it is intended to be used in the real application. To allow comparing the electrical properties of components from different suppliers and comparing the measurement results of different test houses, Annex B.3 defines a reference wiring harness for information only. The crosstalk within the cable bundle assembly is determined by transmission measurements which are performed between the individual channels of the harness.

The DUT shall be placed on a table as shown in Figure 56. All ports of measurement fixtures that are not connected to the VNA but still part of the wiring harness shall be terminated at the coaxial ports of the measurement fixture with single ended 50 Ω .

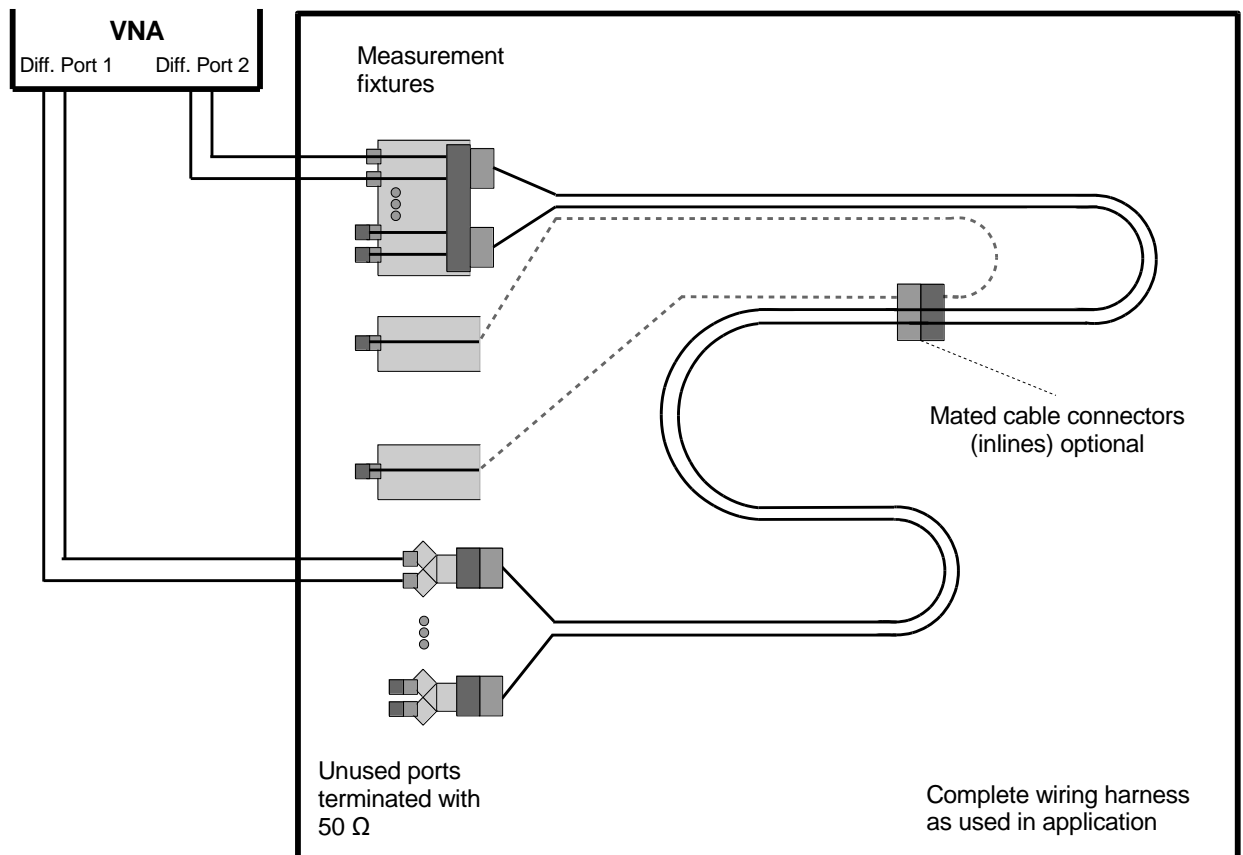

Figure 56: Wiring harness measurement setup for AFEXT Loss and Thru

Figure 56 shows the differential port 1 of the VNA connected to the far end side and port 2 connected to the near end side of the wiring harness, allowing measuring AFEXT Loss and the through connections. The measurement of the through connection for each channel provides insertion loss and return loss in context of the environment system. The insertion loss is also used to calculate PSAACRF.

Figure 57 shows port 1 and port 2 of the VNA connected to the near end side of the wiring harness to measure alien near end crosstalk parameters ANEXT Loss.

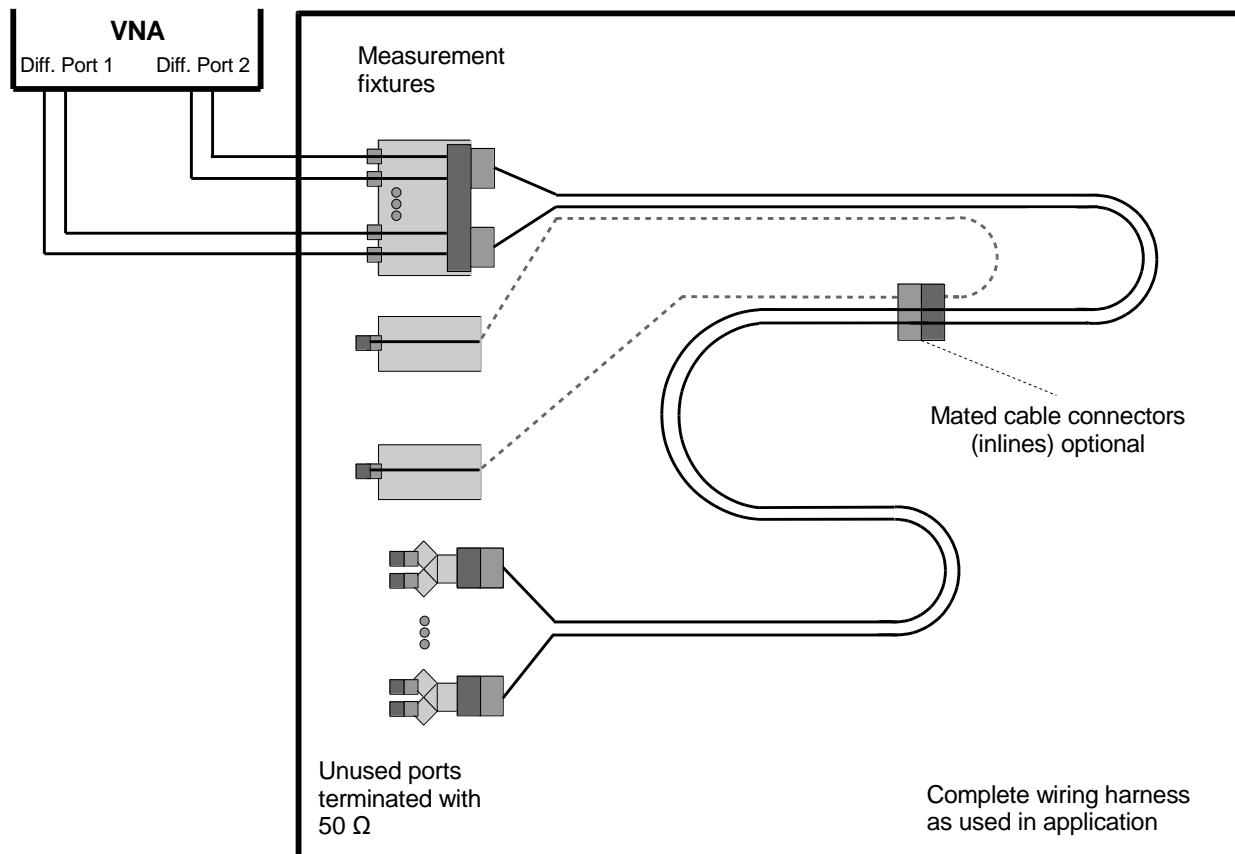

Figure 57: Wiring harness measurement setup for ANEXT Loss

The measurement needs to be repeated for every port combination of the wiring harness. For each port, the power sum crosstalk can be calculated as the sum of crosstalk introduced by each neighboring port. Equations how to calculate the power sum crosstalk from individual transmission measurements are given in Chapter 3.8. Each port to be used with 2.5G/5G/10G shall comply with the specified alien crosstalk requirements in Table 26.

If the WCC contains other data channels than for 1G/2.5G/5G/10G Ethernet, e.g. for coaxial signaling, the crosstalk parameters between the Ethernet channels and the other applications may be measured in addition. In this case, the test fixture for the multiport PCB connector shall provide related traces and test ports as described in Section 5.2.4. The cable side end of these other data channels shall be connected to single port fixtures designed for the corresponding application. Unused ports shall be terminated with the nominal impedance of the application. If the data channel is single ended, i.e. a coaxial cable channel, the corresponding single ended to differential S-parameter S_{dsxy} shall be used for calculating the PSANEXT Loss and PSAACRF values. The limits in Table 26 may also be applied for the data channels other than 1G/2.5G/5G/10G Ethernet if no specific requirements are given by their application.

6.3.5 Whole Communication Channel Setup for ES – Coupling and Screening Attenuation

Decoupling within the context of WCC ES is ensured by meeting the coupling attenuation requirements for connectors (Table 23) and cables (Table 24). To make sure that the combination of connector and cable provide sufficient decoupling, the reference channel assembly as shown in Figure 58 shall be measured. In contrast to the reference cable assembly, which verifies the combination of cable and cable connector, the reference channel assembly additionally includes a PCB connector and a mated combination of plug and socket cable connectors.

Additional information on the reference channel assembly is given in Annex B.2. With respect to the dimensions of the channel assembly, the use of a triaxial tube with nominal length 1 m is implied.

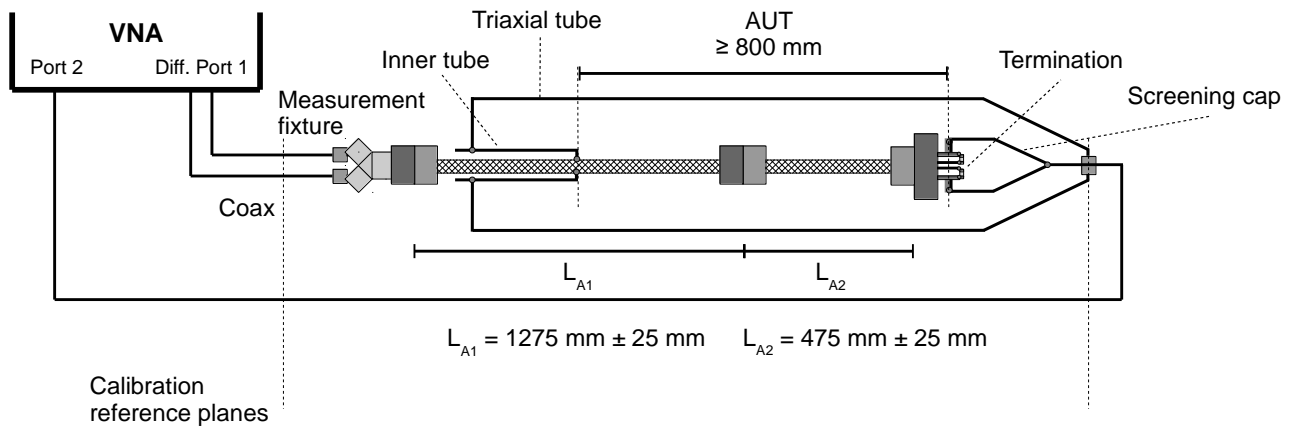

Figure 58: Coupling and screening attenuation reference channel assembly

The correction methods for a_c and a_s as described in Section 3.8 shall be applied to the VNA measurement results. The reference channel assembly shall comply with the coupling and screening attenuation requirements in Table 26.

7 Electrical Requirements

7.1 Requirements for Standalone Communication Channel

7.1.1 Requirements for Connectors in Context of SCC

This section specifies the signal integrity requirements for connectors in context of SCC. Coupling parameter requirements for connectors in context of ES are defined in Chapter 7.2.1.

Table 18: Electrical requirements for mated connector pairs (SCC context, method A)

Test parameter	Symbol or related S-parameter	Speed grade	Requirement
RL	S_{dd11}, S_{dd22}	1G	$\geq \begin{cases} 30 & 1 \leq f < 190 \\ 20 - 20 \log_{10} \left(\frac{f}{600} \right) & 190 \leq f \leq 600 \end{cases} dB$ $1 \leq f \leq 600$, frequency f in MHz
		2.5G	$\geq 25 dB$ $1 \leq f \leq 1000$, frequency f in MHz
		5G	$\geq \begin{cases} 25 & 1 \leq f < 1500 \\ 25 - 16.6 \log_{10} \left(\frac{f}{1500} \right) & 1500 \leq f \leq 2000 \end{cases} dB$ $1 \leq f \leq 2000$, frequency f in MHz
		10G	$\geq \begin{cases} 25 & 1 \leq f < 1500 \\ 25 - 16.6 \log_{10} \left(\frac{f}{1500} \right) & 1500 \leq f < 3000 \\ 20 & 3000 \leq f \leq 4000 \end{cases} dB$ $1 \leq f \leq 4000$, frequency f in MHz
IL	S_{dd21}	1G	$\leq 0.01\sqrt{f} dB$ $1 \leq f \leq 600$, frequency f in MHz
		2.5G	$\leq 0.01\sqrt{f} dB$ $1 \leq f \leq 1000$, frequency f in MHz
		5G	$\leq 0.01\sqrt{f} dB$ $1 \leq f \leq 2000$, frequency f in MHz
		10G	$\leq 0.01\sqrt{f} dB$ $1 \leq f \leq 4000$, frequency f in MHz
Propagation Delay	t_d	1G	$\leq 667ps$ $2 \leq f \leq 600$, frequency f in MHz
		2.5G	$\leq 667ps$ $2 \leq f \leq 1000$, frequency f in MHz
		5G	$\leq 667ps$ $2 \leq f \leq 2000$, frequency f in MHz

		10G	$\leq 667ps$ $2 \leq f \leq 4000$, frequency f in MHz
--	--	-----	---

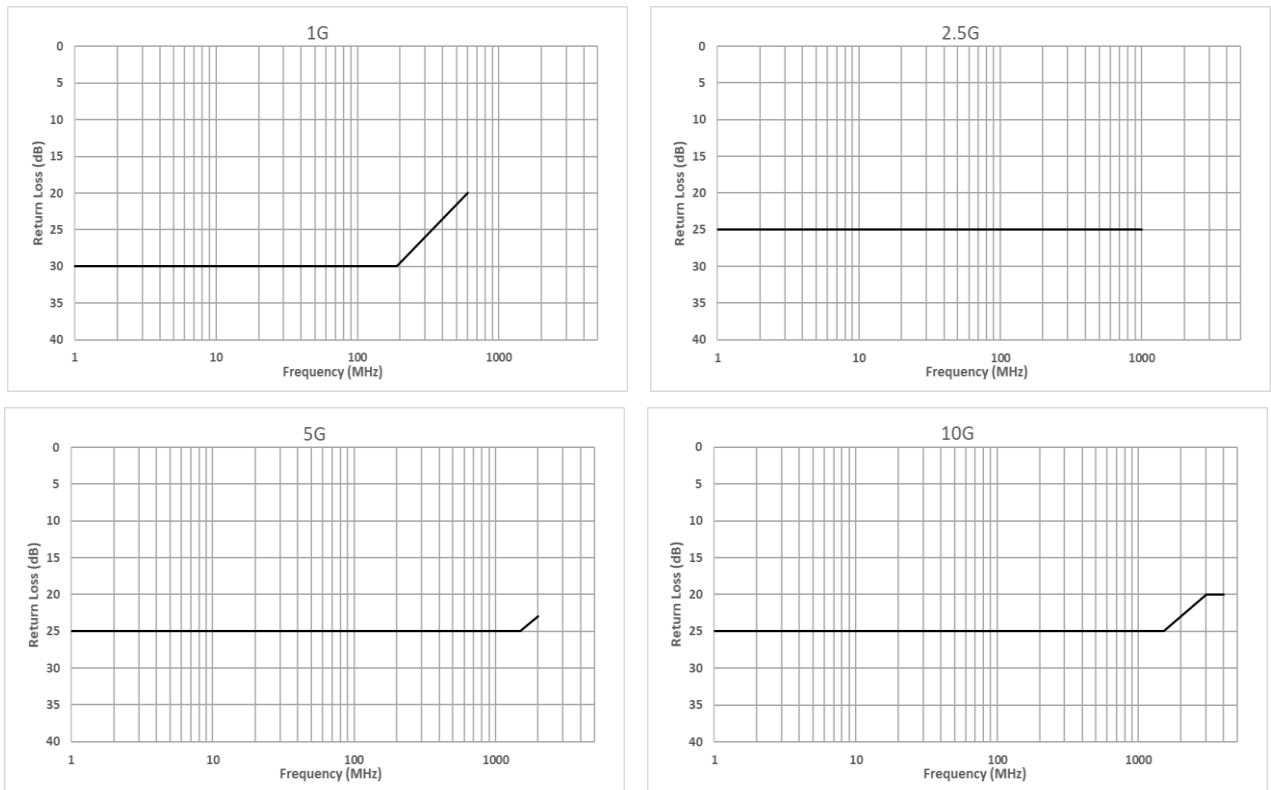

Figure 59: Return loss requirements for mated connector pairs (method A)

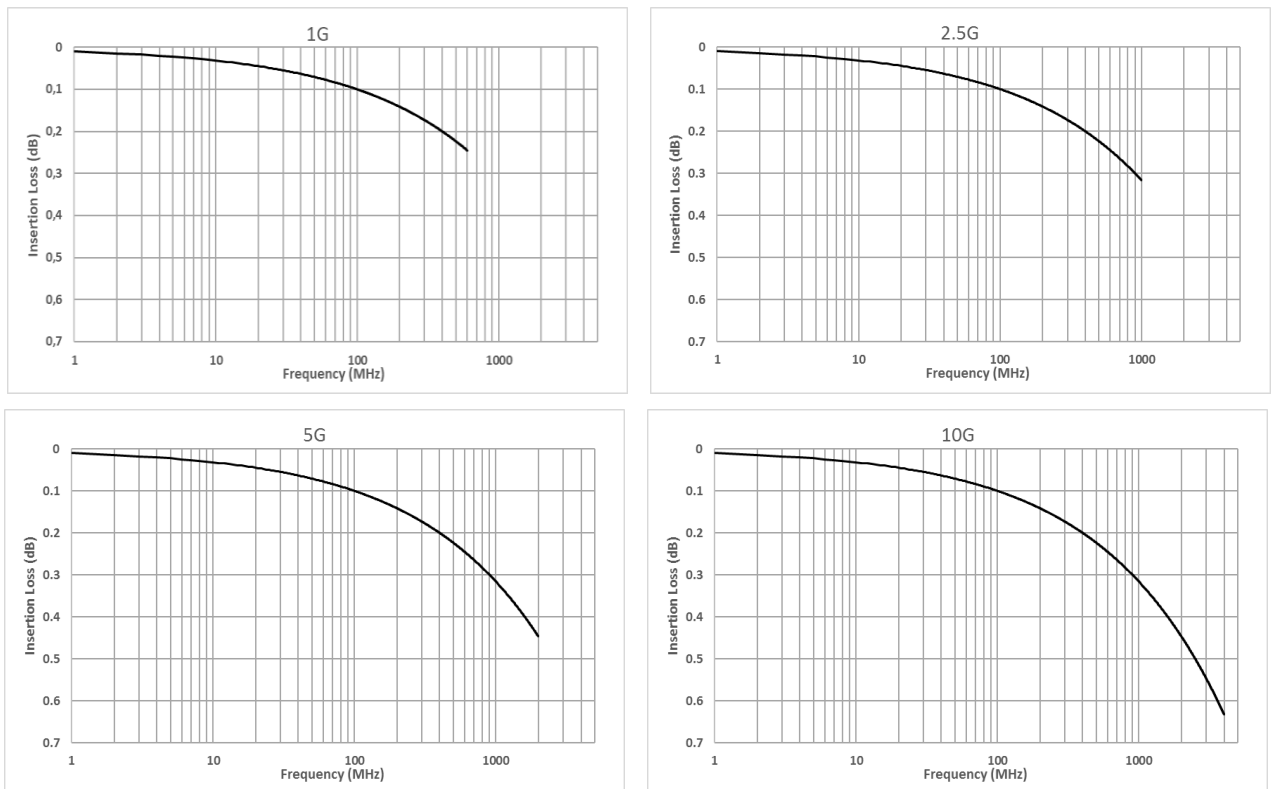

Figure 60: Insertion loss requirements for mated connector pairs (method A)

Table 19: Electrical requirements for single connector components (SCC context, method B)

Test parameter	Symbol or related S-parameter	Speed grade	Requirement
Return Loss	S_{dd11}, S_{dd22}	1G	$\geq \begin{pmatrix} 30 & 1 \leq f < 337 \\ 25 - 20 \log_{10} \left(\frac{f}{600} \right) & 337 \leq f \leq 600 \end{pmatrix} dB$ $1 \leq f \leq 600$, frequency f in MHz
		2.5G	$\geq 30 \text{ dB}$ $1 \leq f \leq 1000$, frequency f in MHz
		5G	$\geq \begin{pmatrix} 30 & 1 \leq f < 1500 \\ 30 - 16.6 \log_{10} \left(\frac{f}{1500} \right) & 1500 \leq f \leq 2000 \end{pmatrix} dB$ $1 \leq f \leq 2000$, frequency f in MHz
		10G	$\geq \begin{pmatrix} 30 & 1 \leq f < 1500 \\ 30 - 16.6 \log_{10} \left(\frac{f}{1500} \right) & 1500 \leq f < 3000 \\ 25 & 3000 \leq f \leq 4000 \end{pmatrix} dB$ $1 \leq f \leq 4000$, frequency f in MHz

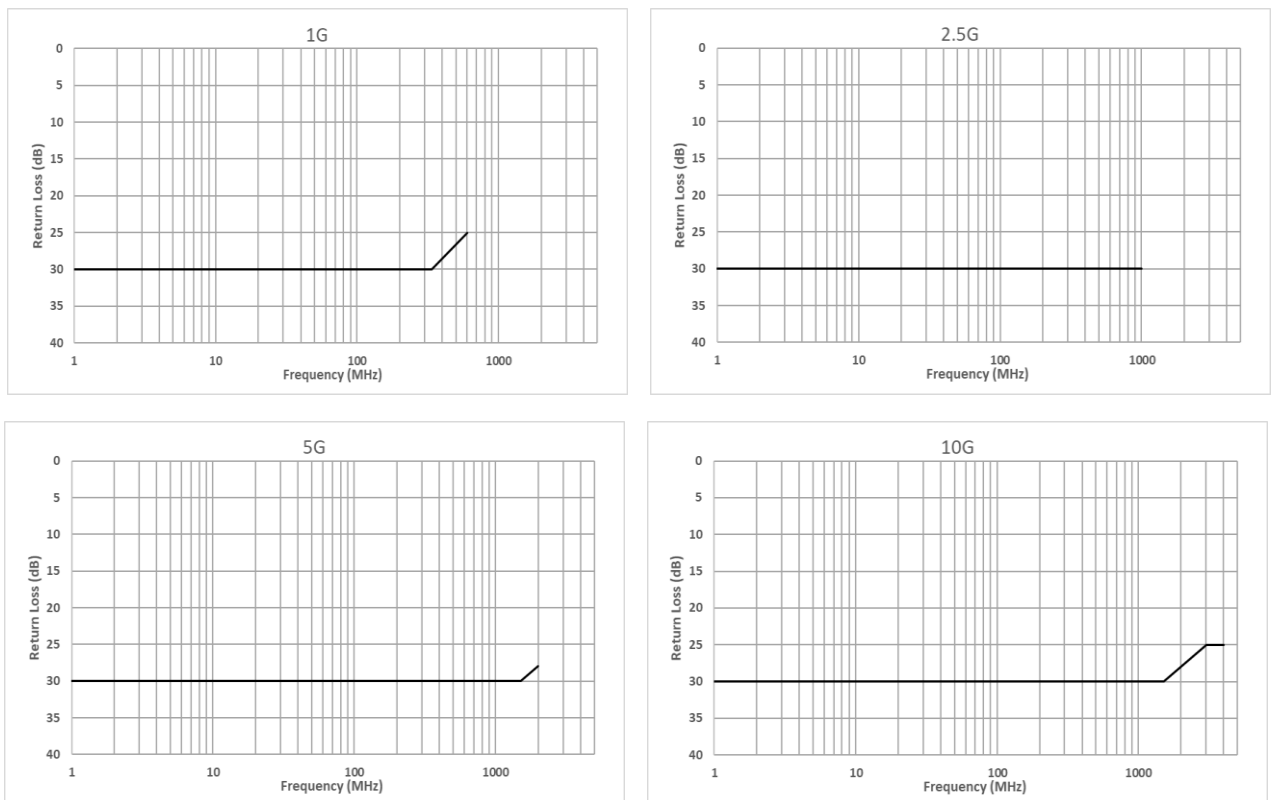

Figure 61: Return loss requirements for single connector components (method B)

7.1.2 Requirements for Cables in Context of SCC

This section specifies the signal integrity requirements for cables in context of the SCC. Coupling parameter requirements for cables in context of ES defined in Chapter 7.2.2.

Table 20: Electrical requirements for cables (SCC context)

Test parameter	Symbol or related S-parameter	Speed grade	Requirement
CIDM	Z_{RF}	1G	$100 \Omega \pm 5 \%$ (at 500 ps rise time)
		2.5G	$100 \Omega \pm 3 \%$ (at 500 ps rise time)
		5G	$100 \Omega \pm 3 \%$ (at 500 ps rise time)
		10G	$100 \Omega \pm 3 \%$ (at 500 ps rise time)
Propagation Delay	t_d	<u>Low loss case⁶: Low loss / low propagation delay cables for use in SCC with total length up to at least 15 m</u>	
		1G	$\leq 6 \text{ ns/m}$ $2 \leq f \leq 600$, frequency f in MHz
		2.5G	$\leq 6 \text{ ns/m}$ $2 \leq f \leq 1000$, frequency f in MHz
		5G	$\leq 6 \text{ ns/m}$ $2 \leq f \leq 2000$, frequency f in MHz
		10G	$\leq 6 \text{ ns/m}$ $2 \leq f \leq 4000$, frequency f in MHz
		<u>Standard loss case⁶: Standard cables for use in SCC with total length up to at least 10 m</u>	
		1G	$\leq 9 \text{ ns/m}$ $2 \leq f \leq 600$, frequency f in MHz
		2.5G	$\leq 9 \text{ ns/m}$ $2 \leq f \leq 1000$, frequency f in MHz
		5G	$\leq 9 \text{ ns/m}$ $2 \leq f \leq 2000$, frequency f in MHz
		10G	$\leq 9 \text{ ns/m}$ $2 \leq f \leq 4000$, frequency f in MHz
IL	S_{dd21}	<u>Low loss case⁶: Low loss / low propagation delay cables for use in SCC with total length up to at least 15 m</u>	
		1G	$\leq \frac{1}{15} \left(0.0023f + 0.5307\sqrt{f} + \frac{0.0639}{\sqrt{f}} \right) \text{ dB/m}$ $1 \leq f \leq 600$, frequency f in MHz

⁶ See Section 3.3 for explanation of low loss case and standard loss case.

		2.5G	$\leq \frac{1}{15} (0.002f + 0.68f^{0.45} - 0.05\sqrt{f}) dB/m$ $1 \leq f \leq 1000$, frequency f in MHz
		5G	$\leq \frac{1}{15} (0.002f + 0.68f^{0.45} - 0.05\sqrt{f}) dB/m$ $1 \leq f \leq 2000$, frequency f in MHz
		10G	$\leq \frac{1}{15} (0.002f + 0.68f^{0.45} - 0.05\sqrt{f}) dB/m$ $1 \leq f \leq 4000$, frequency f in MHz
		<u>Standard loss case⁶: Standard cables for use in SCC with total length up to at least 10 m</u>	
		1G	$\leq \frac{1}{10} \left(0.0023f + 0.5307\sqrt{f} + \frac{0.0639}{\sqrt{f}} \right) dB/m$ $1 \leq f \leq 600$, frequency f in MHz
		2.5G	$\leq \frac{1}{10} (0.002f + 0.68f^{0.45} - 0.05\sqrt{f}) dB/m$ $1 \leq f \leq 1000$, frequency f in MHz
		5G	$\leq \frac{1}{10} (0.002f + 0.68f^{0.45} - 0.05\sqrt{f}) dB/m$ $1 \leq f \leq 2000$, frequency f in MHz
		10G	$\leq \frac{1}{10} (0.002f + 0.68f^{0.45} - 0.05\sqrt{f}) dB/m$ $1 \leq f \leq 4000$, frequency f in MHz
RL	S _{dd11} , S _{dd22}	1G	$\geq \begin{pmatrix} 22 & 1 \leq f < 10 \\ 27 - 5 \log_{10}(f) & 10 \leq f < 40 \\ 19 & 40 \leq f < 130 \\ 40 - 10 \log_{10}(f) & 130 \leq f < 400 \\ 14 & 400 \leq f \leq 600 \end{pmatrix} dB$ $1 \leq f \leq 600$, frequency f in MHz
		2.5G	$\geq \begin{pmatrix} 22 & 1 \leq f < 10 \\ 22 + 8.6 \log_{10}(f/10) & 10 \leq f < 30 \\ 26 & 30 \leq f < 604 \\ 26 - 10 \log_{10}(f/604) & 604 \leq f \leq 1000 \end{pmatrix} dB$ $1 \leq f \leq 1000$, frequency f in MHz
		5G	$\geq \begin{pmatrix} 22 & 1 \leq f < 10 \\ 22 + 8.6 \log_{10}(f/10) & 10 \leq f < 30 \\ 26 & 30 \leq f < 604 \\ 26 - 10 \log_{10}(f/604) & 604 \leq f \leq 2000 \end{pmatrix} dB$ $1 \leq f \leq 2000$, frequency f in MHz

		10G	$\geq \begin{pmatrix} 22 & 1 \leq f < 10 \\ 22 + 8.6 \log_{10}(f/10) & 10 \leq f < 30 \\ 26 & 30 \leq f < 604 \\ 26 - 10 \log_{10}(f/604) & 604 \leq f < 3000 \\ 19 & 3000 \leq f \leq 4000 \end{pmatrix} dB$ $1 \leq f \leq 4000, \text{ frequency } f \text{ in MHz}$
LCTL	S_{dc21}, S_{dc12}	1G	Informative: $\geq 20 dB$ $1 \leq f \leq 600, \text{ frequency } f \text{ in MHz}$
		2.5G	$\geq 20 dB$ $1 \leq f \leq 1000, \text{ frequency } f \text{ in MHz}$
		5G	$\geq 20 dB$ $1 \leq f \leq 2000, \text{ frequency } f \text{ in MHz}$
		10G	$\geq 20 dB$ $1 \leq f \leq 4000, \text{ frequency } f \text{ in MHz}$

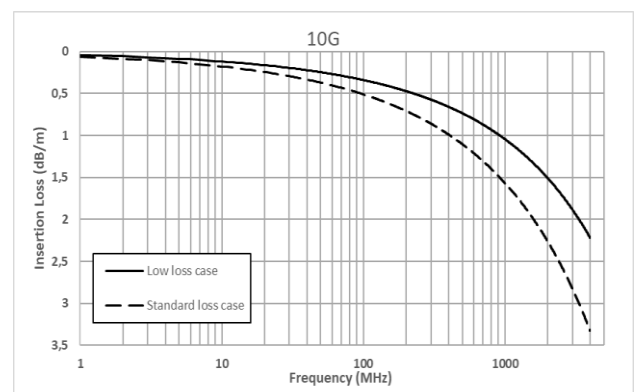
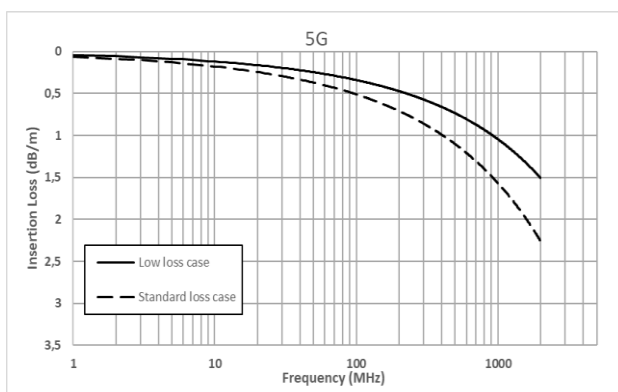
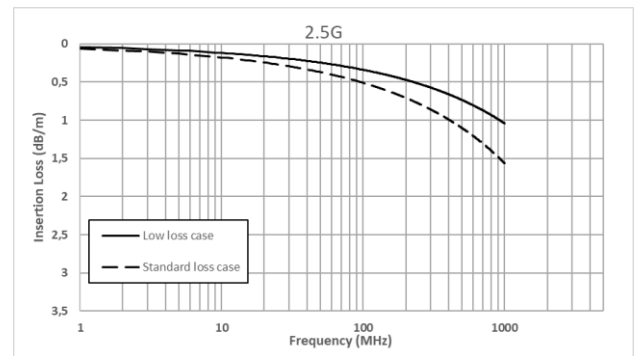
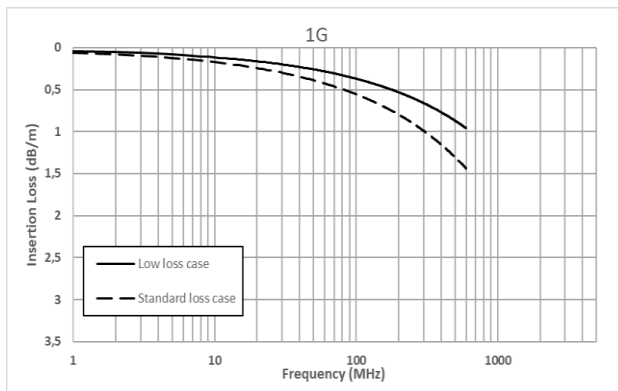

Figure 62: Insertion loss requirements for cables

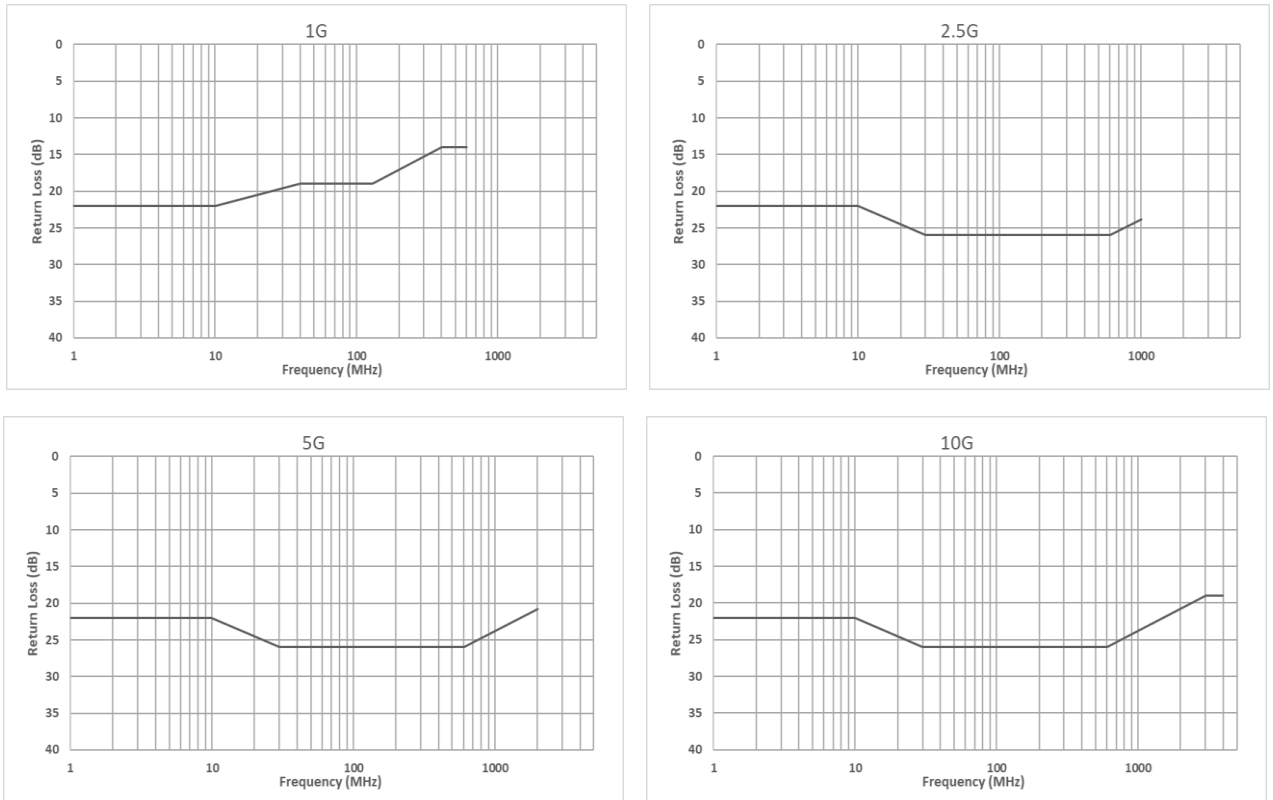

Figure 63:Return loss limit for cables

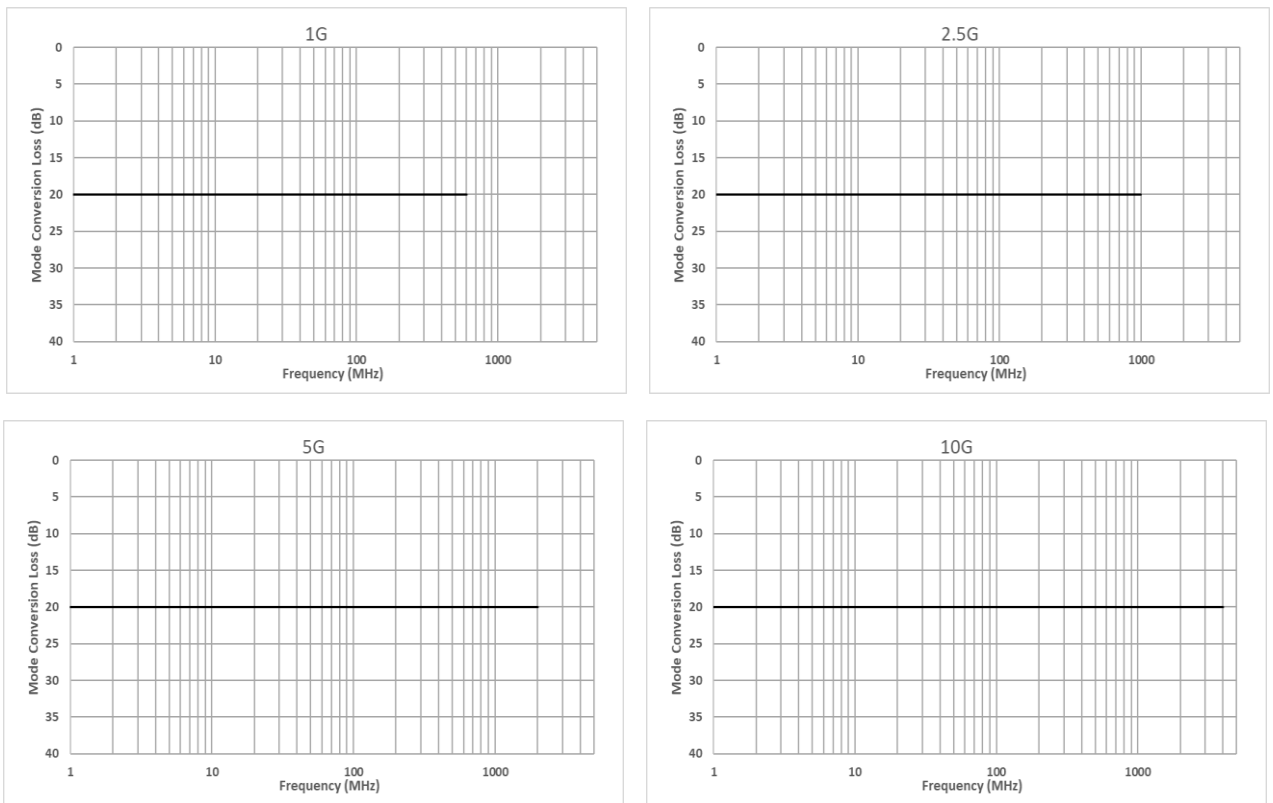

Figure 64:LCTL limit for cables

7.1.3 Requirements for Cable Assemblies in Context of SCC

This section specifies the signal integrity requirements for cable assemblies in context of SCC. Coupling parameter requirements for cable assemblies in context of ES are defined in Chapter 7.2.3.

Table 21: Electrical requirements for cable assemblies (SCC context)

Test parameter	Related S-parameter	Speed grade	Requirement
IL	S _{dd21}	<u>Low loss case⁷: Cable assemblies using low loss case cables in Table 20</u>	
		<u>L_A is the cable assembly length in meters</u>	
		1G	$\leq 0.01\sqrt{f} + \frac{L_A}{15} \left(0.0023f + 0.5307\sqrt{f} + 0.0639/\sqrt{f} \right) dB$ 1 ≤ f ≤ 600, frequency f in MHz
		2.5G	$\leq 0.01\sqrt{f} + \frac{L_A}{15} (0.002f + 0.68f^{0.45} - 0.05\sqrt{f}) dB$ 1 ≤ f ≤ 1000, frequency f in MHz
		5G	$\leq 0.01\sqrt{f} + \frac{L_A}{15} (0.002f + 0.68f^{0.45} - 0.05\sqrt{f}) dB$ 1 ≤ f ≤ 2000, frequency f in MHz
		10G	$\leq 0.01\sqrt{f} + \frac{L_A}{15} (0.002f + 0.68f^{0.45} - 0.05\sqrt{f}) dB$ 1 ≤ f ≤ 4000, frequency f in MHz
		<u>Standard loss case⁷: Cable assemblies using standard loss case cables in Table 20</u>	
		<u>L_A is the cable assembly length in meters</u>	
		1G	$\leq 0.01\sqrt{f} + \frac{L_A}{10} \left(0.0023f + 0.5307\sqrt{f} + 0.0639/\sqrt{f} \right) dB$ 1 ≤ f ≤ 600, frequency f in MHz
		2.5G	$\leq 0.01\sqrt{f} + \frac{L_A}{10} (0.002f + 0.68f^{0.45} - 0.05\sqrt{f}) dB$ 1 ≤ f ≤ 1000, frequency f in MHz
		5G	$\leq 0.01\sqrt{f} + \frac{L_A}{10} (0.002f + 0.68f^{0.45} - 0.05\sqrt{f}) dB$ 1 ≤ f ≤ 2000, frequency f in MHz
		10G	$\leq 0.01\sqrt{f} + \frac{L_A}{10} (0.002f + 0.68f^{0.45} - 0.05\sqrt{f}) dB$ 1 ≤ f ≤ 4000, frequency f in MHz
RL	S _{dd11} , S _{dd22}	1G	$\geq \begin{pmatrix} 22 & 1 \leq f < 130 \\ 56.64 - 16.38 \log_{10}(f) & 130 \leq f < 400 \\ 14 & 400 \leq f \leq 600 \end{pmatrix} dB$ 1 ≤ f ≤ 600, frequency f in MHz

⁷ See Section 3.3 for explanation of low loss case and standard loss case.

	2.5G	$\geq \begin{pmatrix} 21 & 1 \leq f < 10 \\ 21 + 4.2 \log_{10}\left(\frac{f}{10}\right) & 10 \leq f < 90 \\ 25 & 90 \leq f < 480 \\ 25 - 10 \log_{10}\left(\frac{f}{480}\right) & 480 \leq f \leq 1000 \end{pmatrix} dB$ <p>$1 \leq f \leq 1000$, frequency f in MHz</p>
	5G	$\geq \begin{pmatrix} 21 & 1 \leq f < 10 \\ 21 + 4.2 \log_{10}\left(\frac{f}{10}\right) & 10 \leq f < 90 \\ 25 & 90 \leq f < 480 \\ 25 - 10 \log_{10}\left(\frac{f}{480}\right) & 480 \leq f \leq 2000 \end{pmatrix} dB$ <p>$1 \leq f \leq 2000$, frequency f in MHz</p>
	10G	$\geq \begin{pmatrix} 21 & 1 \leq f < 10 \\ 21 + 4.2 \log_{10}\left(\frac{f}{10}\right) & 10 \leq f < 90 \\ 25 & 90 \leq f < 480 \\ 17 & 3000 \leq f \leq 4000 \end{pmatrix} dB$ <p>$1 \leq f \leq 4000$, frequency f in MHz</p>

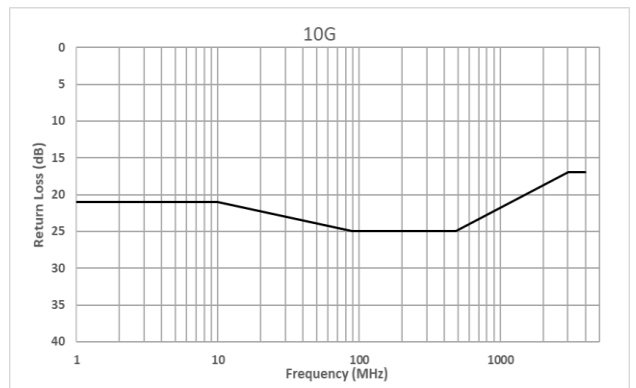
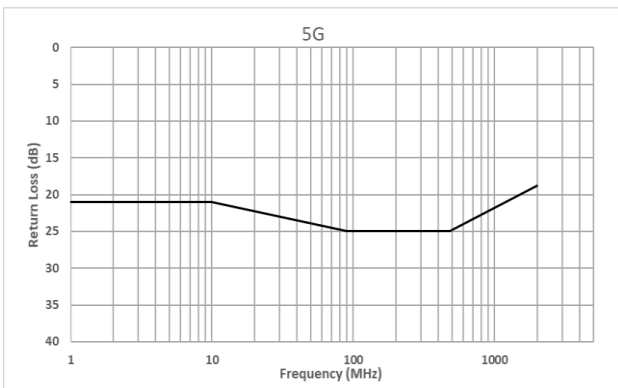
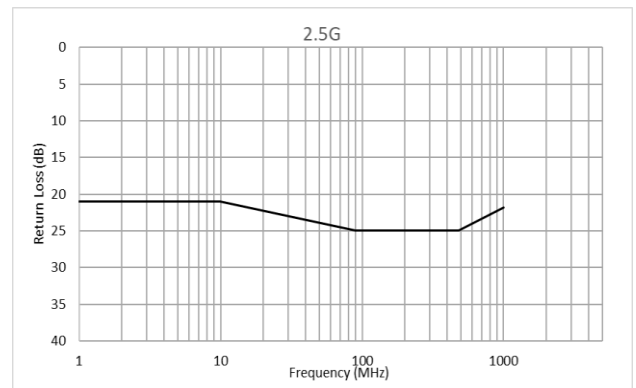
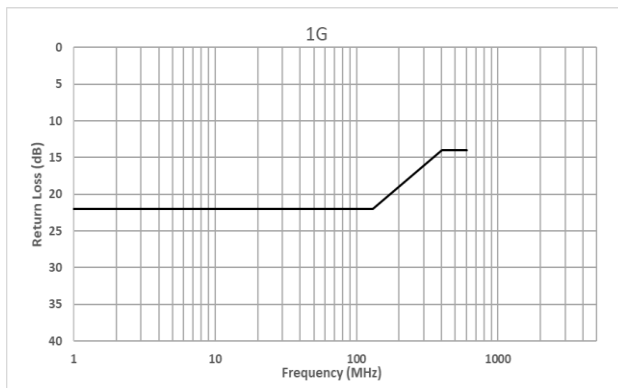

Figure 65: Return loss limit for cable assemblies

7.1.4 Requirements for Whole Communication Channel in Context of SCC

This section specifies the signal integrity requirements for whole communication channels in context of the SCC. Coupling parameter requirements for whole communication channels in context of ES are defined in Chapter 7.2.4.

Table 22: Electrical requirements for whole communication channel (SCC context)

Test parameter	Symbol or related S-parameter	Speed grade	Requirement
Propagation Delay	t_d	1G	$\leq 94 \text{ ns}$ $2 \leq f \leq 600$, frequency f in MHz
		2.5G	$\leq 94 \text{ ns}$ $2 \leq f \leq 1000$, frequency f in MHz
		5G	$\leq 94 \text{ ns}$ $2 \leq f \leq 2000$, frequency f in MHz
		10G	$\leq 94 \text{ ns}$ $2 \leq f \leq 4000$, frequency f in MHz
IL	S_{dd21}	1G	$\leq \left(0.0023f + 0.5907\sqrt{f} + 0.0639/\sqrt{f} \right) \text{ dB}$ $1 \leq f \leq 600$, frequency f in MHz
		2.5G	$\leq (0.002f + 0.68f^{0.45}) \text{ dB}$ $1 \leq f \leq 1000$, frequency f in MHz
		5G	$\leq (0.002f + 0.68f^{0.45}) \text{ dB}$ $1 \leq f \leq 2000$, frequency f in MHz
		10G	$\leq (0.002f + 0.68f^{0.45}) \text{ dB}$ $1 \leq f \leq 4000$, frequency f in MHz
RL	S_{dd11}, S_{dd22}	1G	$\geq \begin{pmatrix} 19 & 1 \leq f < 10 \\ 24 - 5 \log_{10}(f) & 10 \leq f < 40 \\ 16 & 40 \leq f < 130 \\ 37 - 10 \log_{10}(f) & 130 \leq f < 400 \\ 11 & 400 \leq f \leq 600 \end{pmatrix} \text{ dB}$ $1 \leq f \leq 600$, frequency f in MHz
		2.5G	$\geq \begin{pmatrix} 20 & 1 \leq f < 240 \\ 20 - 10 \log_{10}\left(\frac{f}{240}\right) & 240 \leq f \leq 1000 \end{pmatrix} \text{ dB}$ $1 \leq f \leq 1000$, frequency f in MHz
		5G	Long SCC case ⁸ for IL(1.5 GHz) > 15 dB: $\geq \begin{pmatrix} 20 & 1 \leq f < 480 \\ 20 - 10 \log_{10}\left(\frac{f}{480}\right) & 480 \leq f \leq 2000 \end{pmatrix} \text{ dB}$ $1 \leq f \leq 2000$, frequency f in MHz

⁸ Short and long SCC case definitions allow RL relaxation for SCC with low IL according to the 5G and 10G link segment requirement definitions in [2]. See 3.3 for detailed explanation.

		<p>Short SCC case⁸ for IL(1.5 GHz) ≤ 15 dB:</p> $\geq \begin{pmatrix} 20 & 1 \leq f < 240 \\ 20 - 10 \log_{10}\left(\frac{f}{240}\right) & 240 \leq f \leq 2000 \end{pmatrix} dB$ <p>1 ≤ f ≤ 2000, frequency f in MHz</p>
	10G	<p>Long SCC case⁸ for IL(3 GHz) > 15 dB:</p> $\geq \begin{pmatrix} 20 & 1 \leq f < 480 \\ 20 - 10 \log_{10}\left(\frac{f}{480}\right) & 480 \leq f < 3000 \\ 12 & 3000 \leq f \leq 4000 \end{pmatrix} dB$ <p>1 ≤ f ≤ 4000, frequency f in MHz</p>
		<p>Short SCC case⁸ for IL(3 GHz) ≤ 15 dB:</p> $\geq \begin{pmatrix} 20 & 1 \leq f < 240 \\ 20 - 10 \log_{10}\left(\frac{f}{240}\right) & 240 \leq f < 3000 \\ 9 & 3000 \leq f \leq 4000 \end{pmatrix} dB$ <p>1 ≤ f ≤ 4000, frequency f in MHz</p>

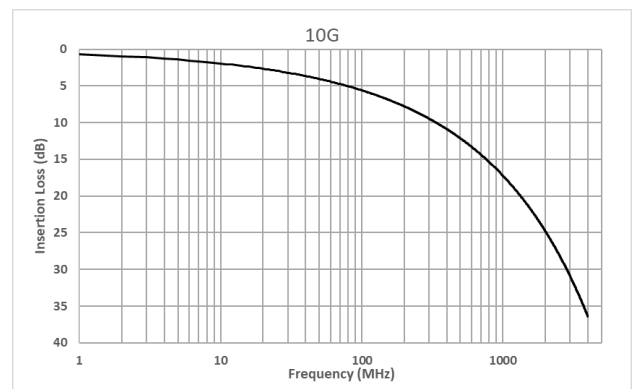
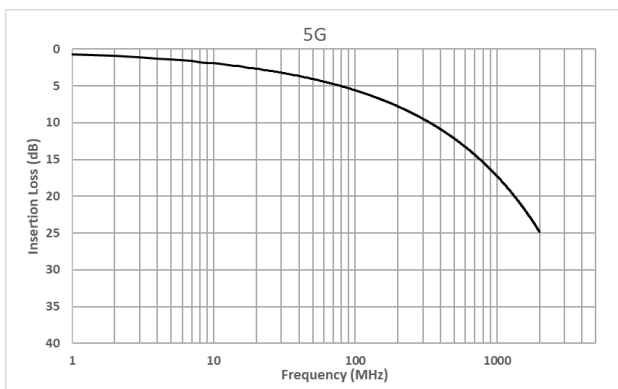
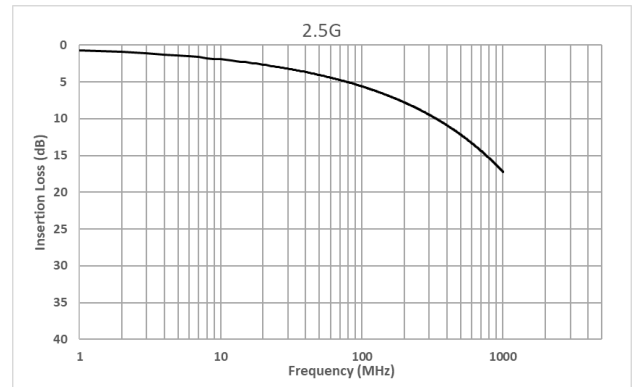
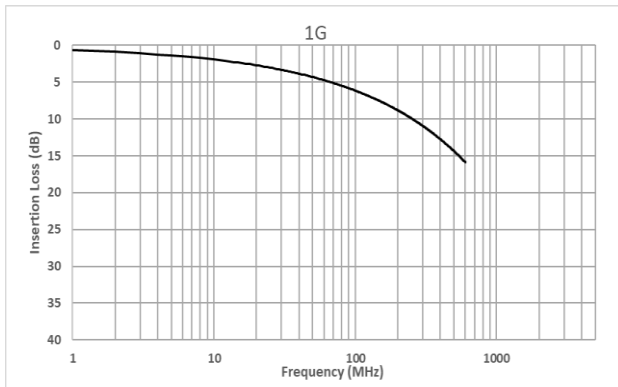

Figure 66: Insertion loss requirements for whole communication channel

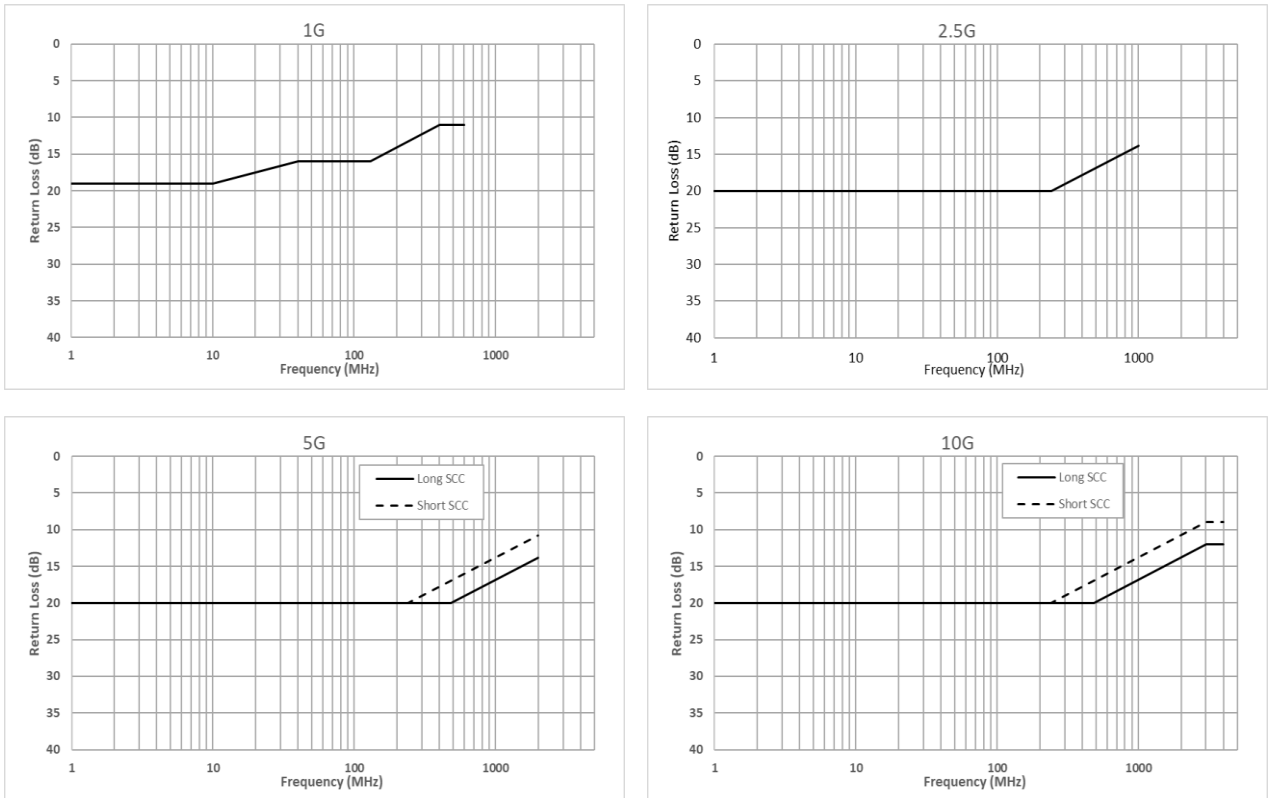

Figure 67: Return loss requirements for whole communication channel

7.2 Requirements for Alien Coupling within Environment System

7.2.1 Requirements for Connectors in Context of ES

This section specifies the coupling parameter requirements for connectors in context of ES. The signal integrity parameter requirements for connectors in context of SCC are defined in Section 7.1.1.

Table 23: Electrical requirements for connectors (ES context)

Test parameter	Symbol or related S-parameter	Speed grade	Requirement
PSANEXT Loss	S_{dd31}, S_{ddyx}	1G	$\geq \begin{pmatrix} 57 - 10 \log_{10} (f/100) & 1 \leq f \leq 100 \\ 57 - 15 \log_{10} (f/100) - 6 (f - 100/400) & 100 < f \leq 600 \end{pmatrix} dB$ $1 \leq f \leq 600$, frequency f in MHz
		2.5G	$\geq \begin{pmatrix} 78 & 1 \leq f \leq 215 \\ 83 - 15 \log_{10} (f/100) & 215 < f \leq 4000 \end{pmatrix} dB$ $1 \leq f \leq 4000$, frequency f in MHz
		5G	$\geq \begin{pmatrix} 78 & 1 \leq f \leq 215 \\ 83 - 15 \log_{10} (f/100) & 215 < f \leq 4000 \end{pmatrix} dB$ $1 \leq f \leq 4000$, frequency f in MHz
		10G	$\geq \begin{pmatrix} 78 & 1 \leq f \leq 215 \\ 83 - 15 \log_{10} (f/100) & 215 < f \leq 4000 \end{pmatrix} dB$ $1 \leq f \leq 4000$, frequency f in MHz
PSAFEXT Loss	S_{dd41}, S_{ddyx}	1G	$\geq (46.67 - 20 \log_{10} (f/100)) dB$ $1 \leq f \leq 600$, frequency f in MHz
		2.5G	$\geq \begin{pmatrix} 78 & 1 \leq f \leq 355 \\ 89 - 20 \log_{10} (f/100) & 355 < f \leq 4000 \end{pmatrix} dB$ $1 \leq f \leq 4000$, frequency f in MHz
		5G	$\geq \begin{pmatrix} 78 & 1 \leq f \leq 355 \\ 89 - 20 \log_{10} (f/100) & 355 < f \leq 4000 \end{pmatrix} dB$ $1 \leq f \leq 4000$, frequency f in MHz
		10G	$\geq \begin{pmatrix} 78 & 1 \leq f \leq 355 \\ 89 - 20 \log_{10} (f/100) & 355 < f \leq 4000 \end{pmatrix} dB$ $1 \leq f \leq 4000$, frequency f in MHz
Coupling Attenuation	a_c	1G	≥ 70 dB $30 \leq f \leq 600$, frequency f in MHz
		2.5G	$\geq \begin{pmatrix} 75 & 30 \leq f < 750 \\ 55 - 20 \log_{10} (f/7500) & 750 \leq f \leq 4000 \end{pmatrix} dB$ $30 \leq f \leq 4000$, frequency f in MHz

		5G	$\geq \begin{cases} 75 & 30 \leq f < 750 \\ 55 - 20 \log_{10}(f/7500) & 750 \leq f \leq 4000 \end{cases} dB$ $30 \leq f \leq 4000, \text{ frequency } f \text{ in MHz}$
		10G	$\geq \begin{cases} 75 & 30 \leq f < 750 \\ 55 - 20 \log_{10}(f/7500) & 750 \leq f \leq 4000 \end{cases} dB$ $30 \leq f \leq 4000, \text{ frequency } f \text{ in MHz}$
Screening Attenuation	a _s	1G	$\geq 45 \text{ dB}$ $30 \leq f \leq 600, \text{ frequency } f \text{ in MHz}$
		2.5G	$\geq 50 \text{ dB}$ $30 \leq f \leq 1000, \text{ frequency } f \text{ in MHz}$
		5G	$\geq 50 \text{ dB}$ $30 \leq f \leq 2000, \text{ frequency } f \text{ in MHz}$
		10G	$\geq 50 \text{ dB}$ $30 \leq f \leq 4000, \text{ frequency } f \text{ in MHz}$

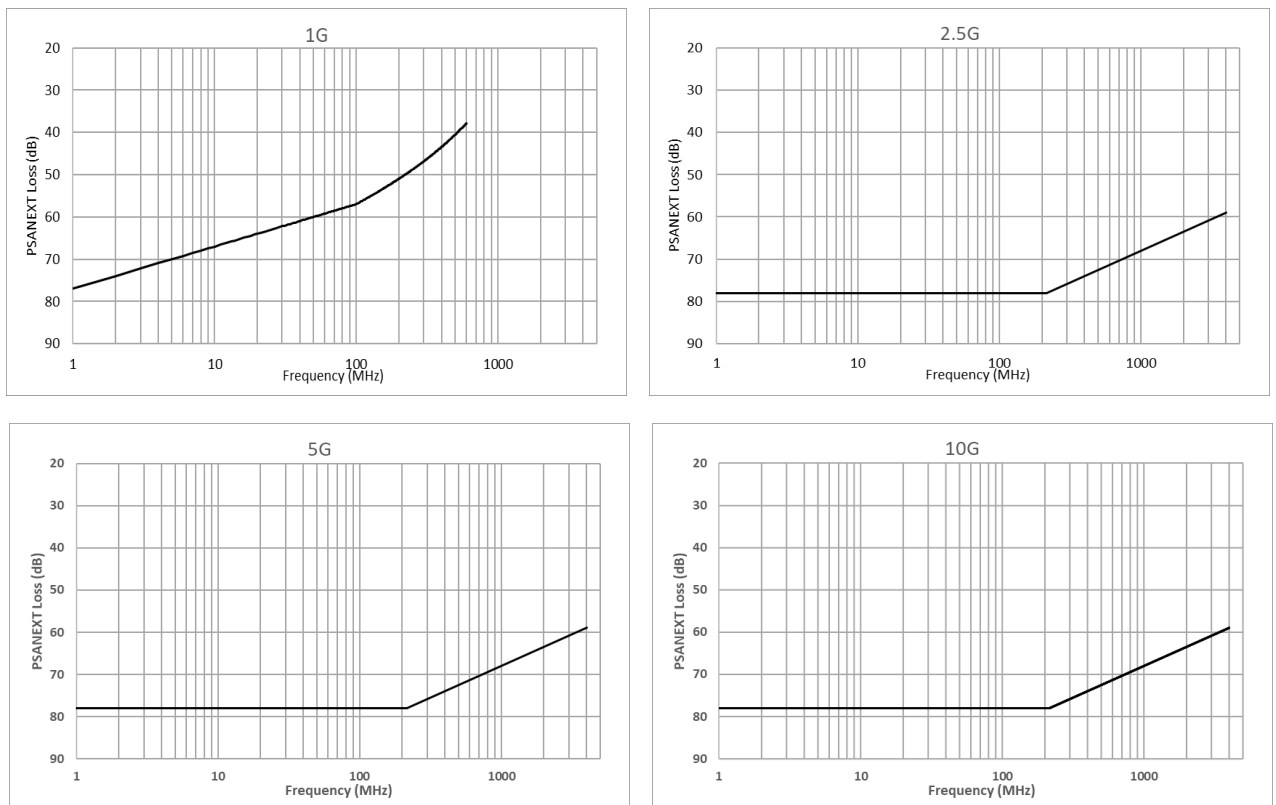

Figure 68: PSANEXT Loss requirements for connectors

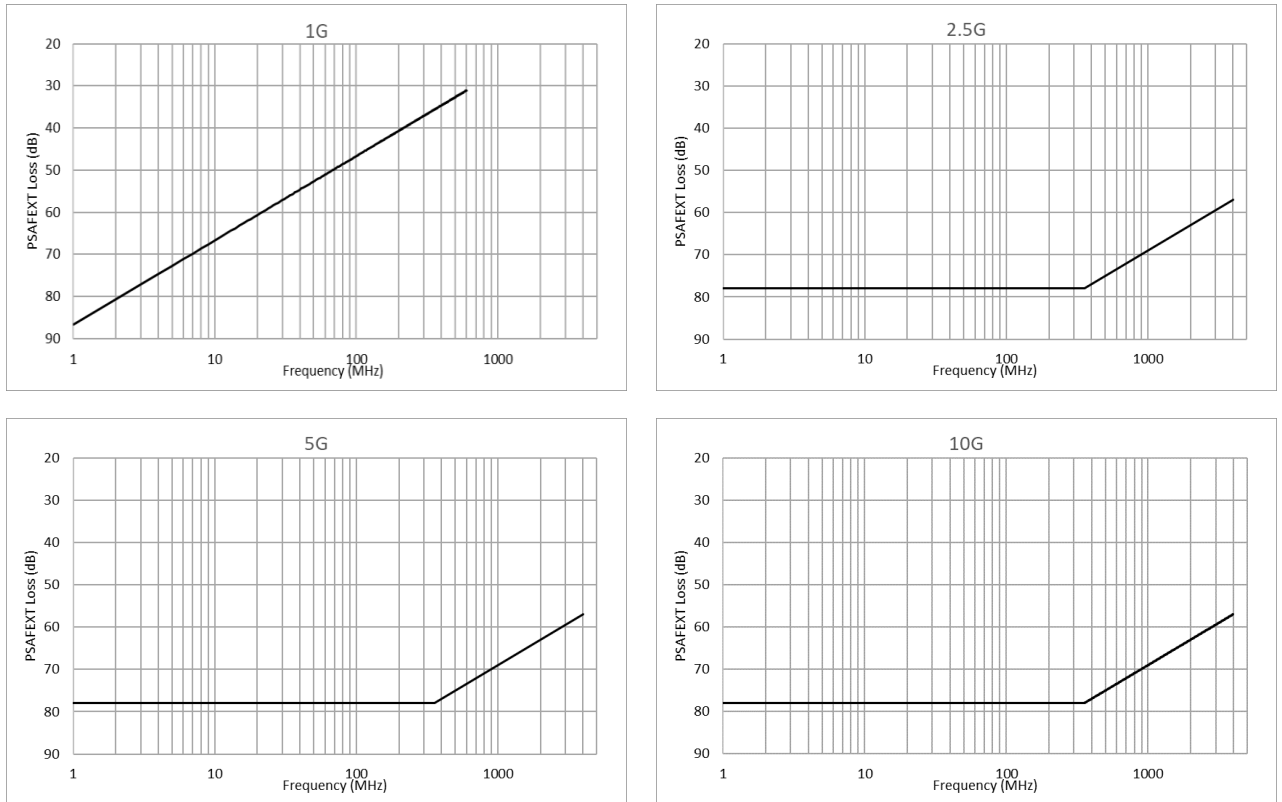

Figure 69: PSAFEXT Loss requirements for connectors

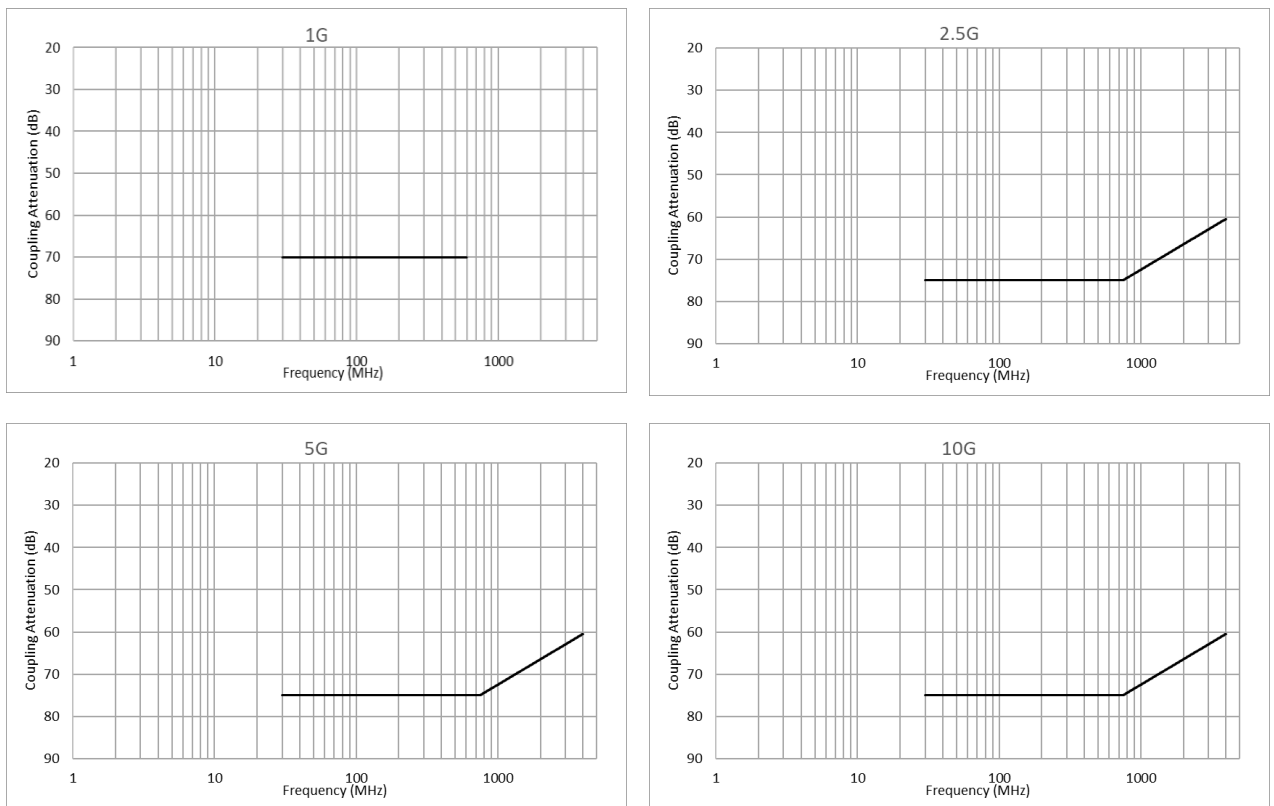

Figure 70: Coupling attenuation requirements for connectors

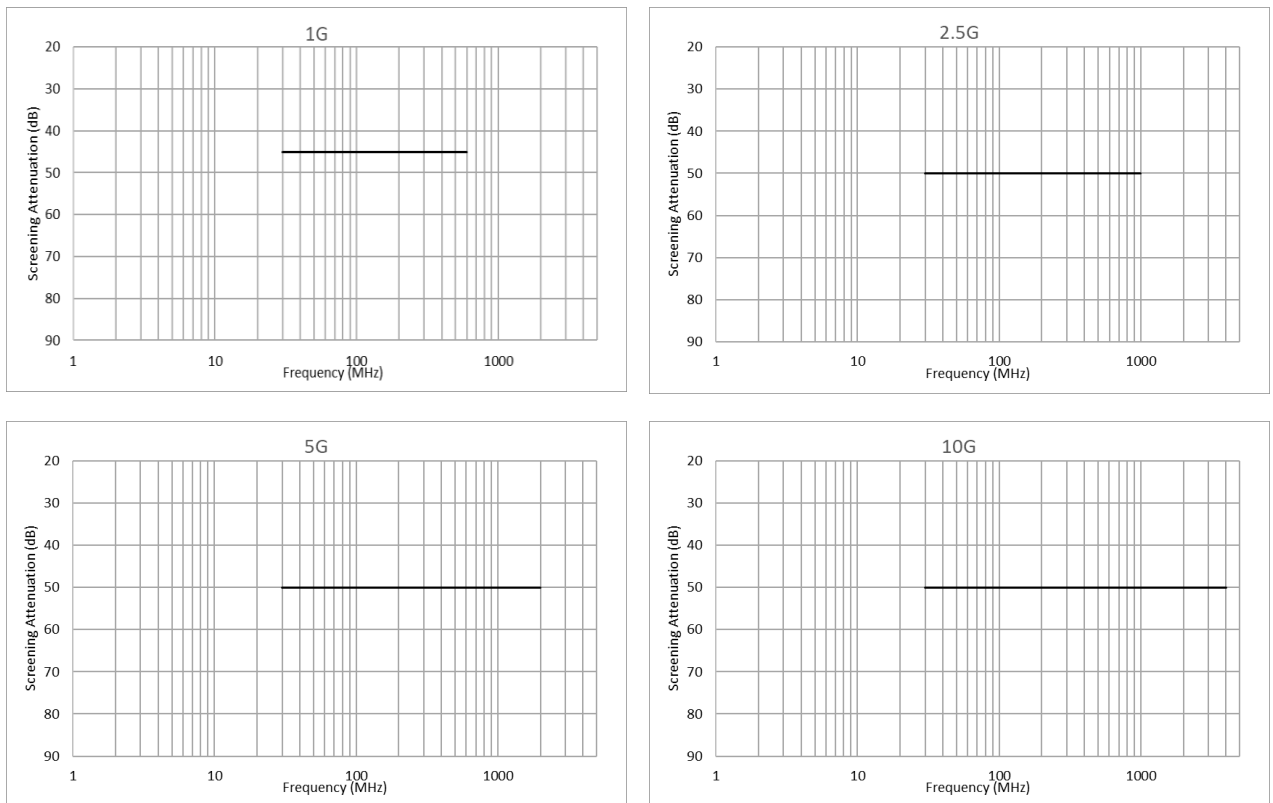

Figure 71: Screening attenuation requirements for connectors

7.2.2 Requirements for Cables in Context of ES

This section specifies the coupling parameter requirements for cables in context of ES. The signal integrity parameter requirements for cables in context of SCC are defined in Section 7.1.2.

Table 24: Electrical requirements for cables (ES context)

Test parameter	Symbol	Speed grade	Requirement
Coupling Attenuation	a_c	1G	≥ 70 dB $30 \leq f \leq 600$, frequency f in MHz
		2.5G	$\geq \begin{pmatrix} 75 & 30 \leq f < 750 \\ 55 - 20\log_{10}(f/7500) & 750 \leq f \leq 4000 \end{pmatrix} dB$ $30 \leq f \leq 4000$, frequency f in MHz
		5G	$\geq \begin{pmatrix} 75 & 30 \leq f < 750 \\ 55 - 20\log_{10}(f/7500) & 750 \leq f \leq 4000 \end{pmatrix} dB$ $30 \leq f \leq 4000$, frequency f in MHz
		10G	$\geq \begin{pmatrix} 75 & 30 \leq f < 750 \\ 55 - 20\log_{10}(f/7500) & 750 \leq f \leq 4000 \end{pmatrix} dB$ $30 \leq f \leq 4000$, frequency f in MHz
Screening Attenuation	a_s	1G	≥ 45 dB $30 \leq f \leq 600$, frequency f in MHz
		2.5G	≥ 50 dB $30 \leq f \leq 1000$, frequency f in MHz
		5G	≥ 50 dB $30 \leq f \leq 2000$, frequency f in MHz
		10G	≥ 50 dB $30 \leq f \leq 4000$, frequency f in MHz

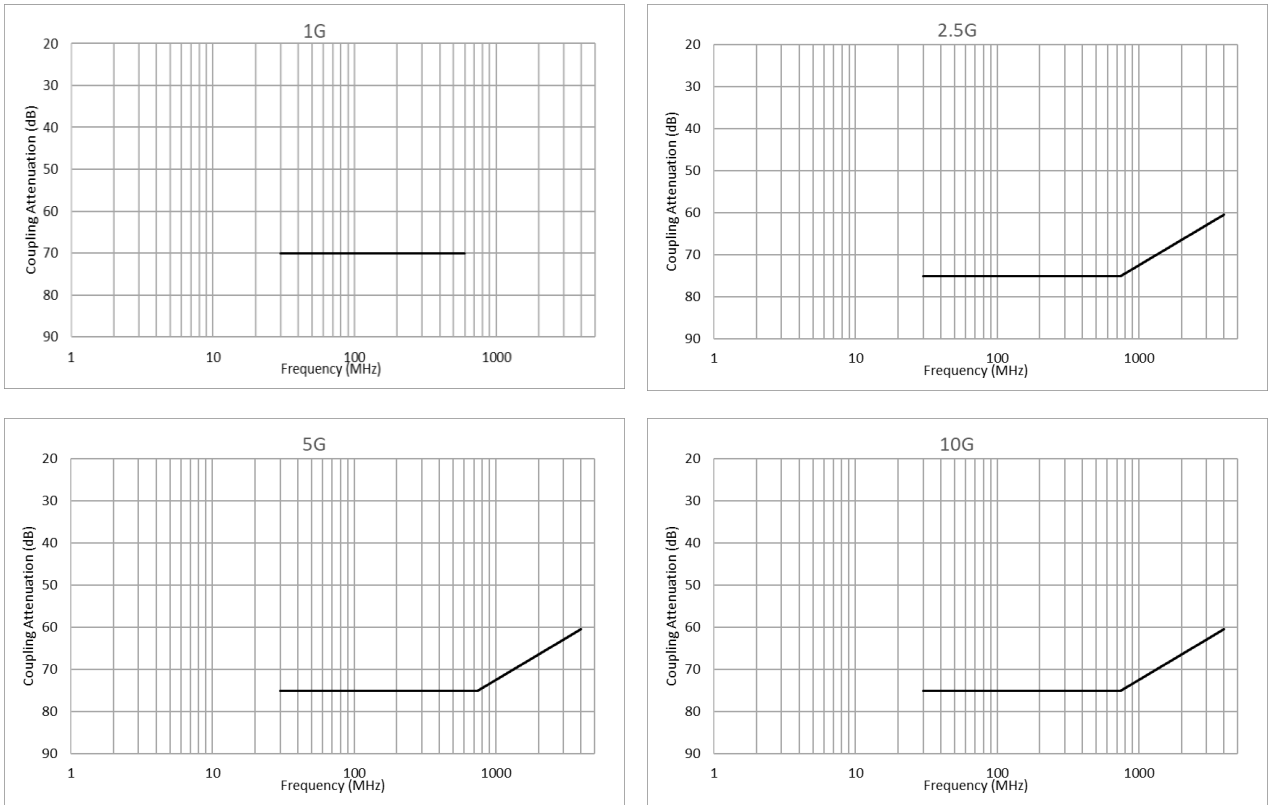

Figure 72: Coupling attenuation requirements for cables

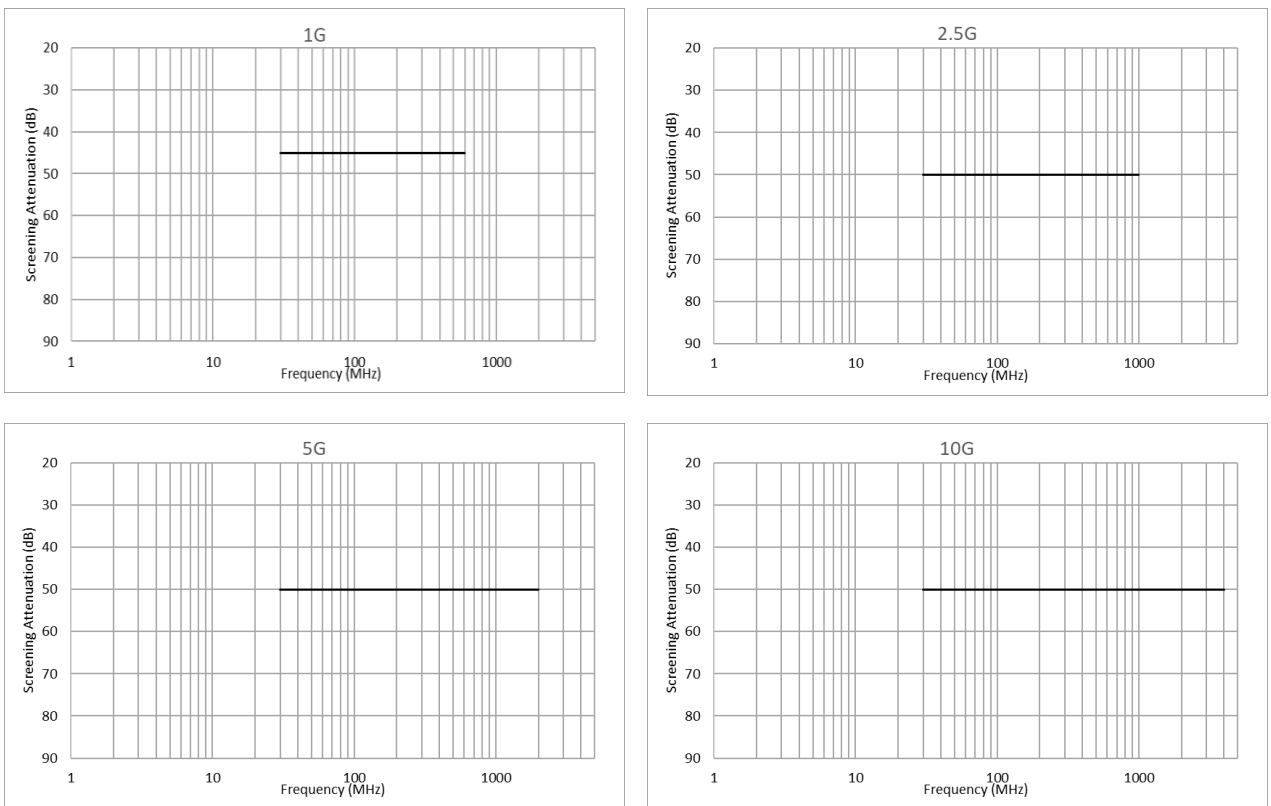

Figure 73: Screening attenuation requirements for cables

7.2.3 Requirements for Cable Assemblies in Context of ES

This section specifies the coupling parameter requirements for cable assemblies in context of ES. The signal integrity parameter requirements for cable assemblies in context of SCC are defined in Section 7.1.3.

Table 25: Electrical requirements for cable assemblies (ES context)

Test parameter	Symbol	Speed grade	Requirement
Coupling Attenuation	a_c	1G	≥ 70 dB $30 \leq f \leq 600$, frequency f in MHz
		2.5G	$\geq \left(\begin{array}{cc} 75 & 30 \leq f < 750 \\ 55 - 20 \log_{10} (f/7500) & 750 \leq f \leq 4000 \end{array} \right) dB$ $30 \leq f \leq 4000$, frequency f in MHz
		5G	$\geq \left(\begin{array}{cc} 75 & 30 \leq f < 750 \\ 55 - 20 \log_{10} (f/7500) & 750 \leq f \leq 4000 \end{array} \right) dB$ $30 \leq f \leq 4000$, frequency f in MHz
		10G	$\geq \left(\begin{array}{cc} 75 & 30 \leq f < 750 \\ 55 - 20 \log_{10} (f/7500) & 750 \leq f \leq 4000 \end{array} \right) dB$ $30 \leq f \leq 4000$, frequency f in MHz
Screening Attenuation	a_s	1G	≥ 45 dB $30 \leq f \leq 600$, frequency f in MHz
		2.5G	≥ 50 dB $30 \leq f \leq 1000$, frequency f in MHz
		5G	≥ 50 dB $30 \leq f \leq 2000$, frequency f in MHz
		10G	≥ 50 dB $30 \leq f \leq 4000$, frequency f in MHz

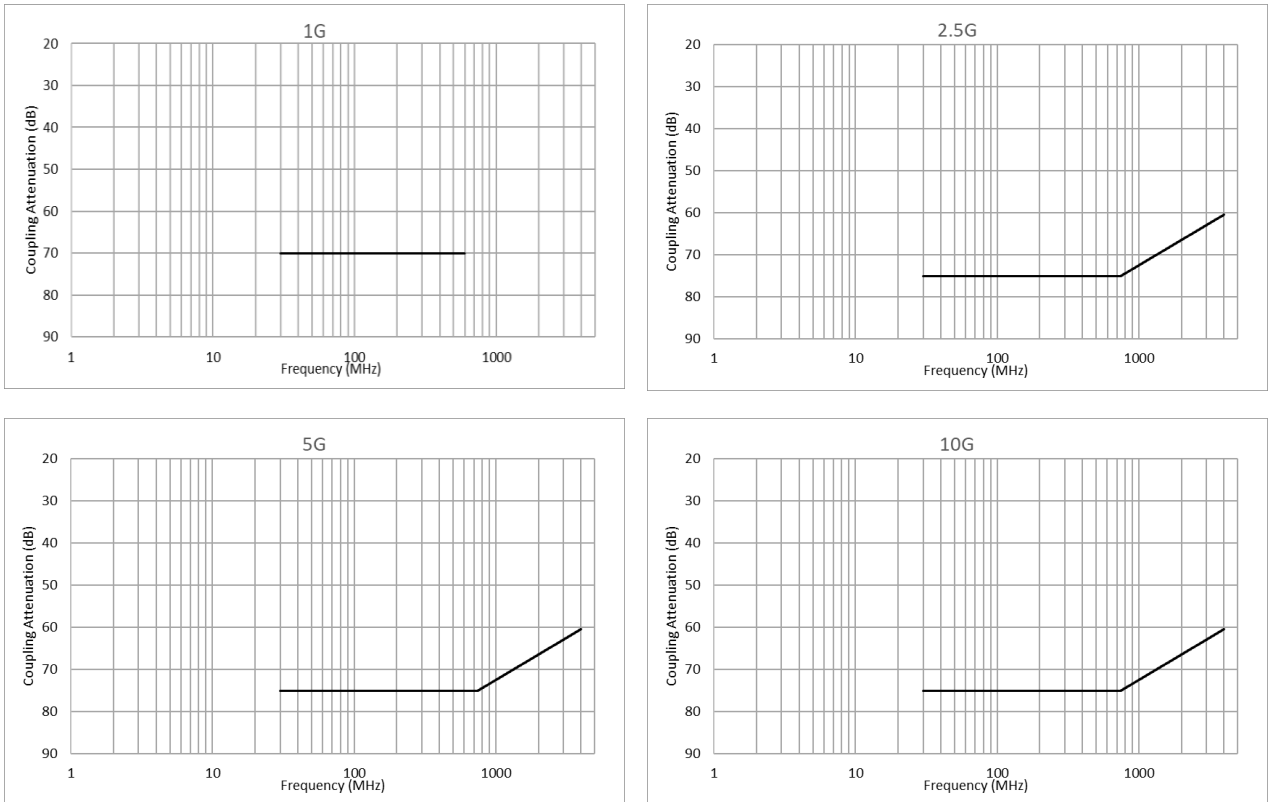

Figure 74: Coupling attenuation requirements for cable assemblies

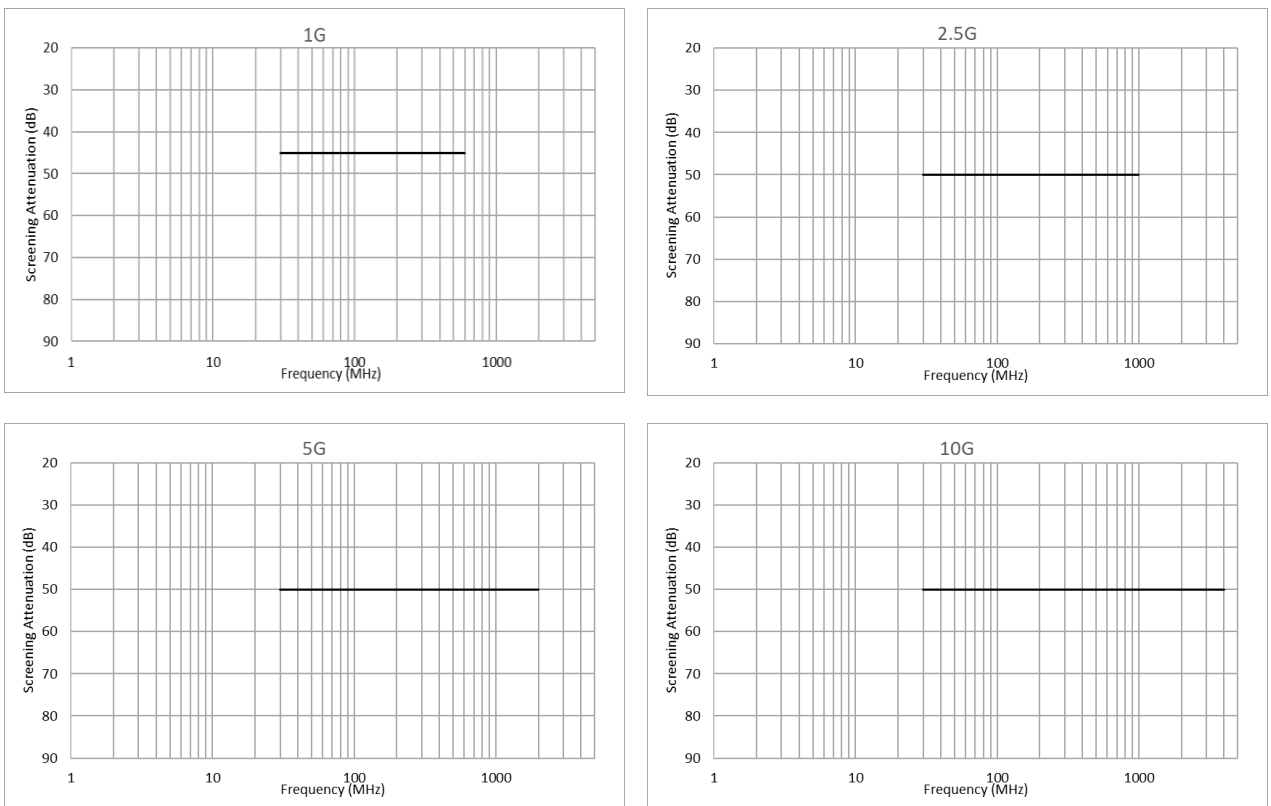

Figure 75: Screening attenuation requirements for cable assemblies

7.2.4 Requirements for Whole Communication Channel in Context of ES

This section specifies the coupling parameter requirements for whole communication channels in context of ES. The signal integrity parameter requirements for whole communication channels in context of SCC are defined in Section 7.1.4.

Table 26: Electrical requirements for WCC (ES context)

Test parameter	Symbol or related S-parameter	Speed grade	Requirement
PSANEXT Loss	S_{dd31}, S_{ddyx}	1G	$\geq \begin{pmatrix} 54 - 10 \log_{10} (f/100) & 1 \leq f \leq 100 \\ 54 - 15 \log_{10} (f/100) - 6 (f - 100/400) & 100 < f \leq 600 \end{pmatrix} dB$ $1 \leq f \leq 600$, frequency f in MHz
		2.5G	$\geq \begin{pmatrix} 75 & 1 \leq f \leq 215 \\ 80 - 15 \log_{10} (f/100) & 215 < f \leq 4000 \end{pmatrix} dB$ $1 \leq f \leq 4000$, frequency f in MHz
		5G	$\geq \begin{pmatrix} 75 & 1 \leq f \leq 215 \\ 80 - 15 \log_{10} (f/100) & 215 < f \leq 4000 \end{pmatrix} dB$ $1 \leq f \leq 4000$, frequency f in MHz
		10G	$\geq \begin{pmatrix} 75 & 1 \leq f \leq 215 \\ 80 - 15 \log_{10} (f/100) & 215 < f \leq 4000 \end{pmatrix} dB$ $1 \leq f \leq 4000$, frequency f in MHz
PSAACRF	S_{dd41}, S_{ddyx}	1G	$\geq (43.67 - 20 \log_{10} (f/100)) dB$ ⁹ $1 \leq f \leq 600$, frequency f in MHz
		2.5G	$\geq \begin{pmatrix} 75 & 1 \leq f \leq 355 \\ 86 - 20 \log_{10} (f/100) & 355 < f \leq 4000 \end{pmatrix} dB$ $1 \leq f \leq 4000$, frequency f in MHz
		5G	$\geq \begin{pmatrix} 75 & 1 \leq f \leq 355 \\ 86 - 20 \log_{10} (f/100) & 355 < f \leq 4000 \end{pmatrix} dB$ $1 \leq f \leq 4000$, frequency f in MHz
		10G	$\geq \begin{pmatrix} 75 & 1 \leq f \leq 355 \\ 86 - 20 \log_{10} (f/100) & 355 < f \leq 4000 \end{pmatrix} dB$ $1 \leq f \leq 4000$, frequency f in MHz
Coupling Attenuation	a_c	1G	≥ 65 dB $30 \leq f \leq 600$, frequency f in MHz

⁹ The equation for PSAACRF is the simplified expression of the same equation as defined [1].

		2.5G	$\geq \begin{pmatrix} 70 & 30 \leq f < 750 \\ 50 - 20 \log_{10} (f/7500) & 750 \leq f < 4000 \end{pmatrix} dB$ $30 \leq f \leq 4000$, frequency f in MHz
		5G	$\geq \begin{pmatrix} 70 & 30 \leq f < 750 \\ 50 - 20 \log_{10} (f/7500) & 750 \leq f < 4000 \end{pmatrix} dB$ $30 \leq f \leq 4000$, frequency f in MHz
		10G	$\geq \begin{pmatrix} 70 & 30 \leq f < 750 \\ 50 - 20 \log_{10} (f/7500) & 750 \leq f < 4000 \end{pmatrix} dB$ $30 \leq f \leq 4000$, frequency f in MHz
Screening Attenuation	a_s	1G	≥ 40 dB $30 \leq f \leq 600$, frequency f in MHz
		2.5G	≥ 45 dB $30 \leq f \leq 1000$, frequency f in MHz
		5G	≥ 45 dB $30 \leq f \leq 2000$, frequency f in MHz
		10G	≥ 45 dB $30 \leq f \leq 4000$, frequency f in MHz

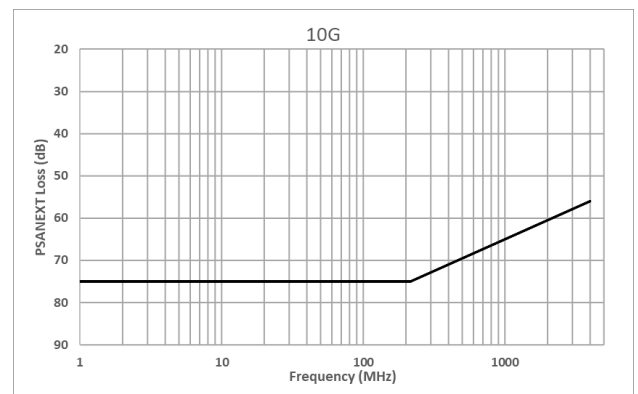
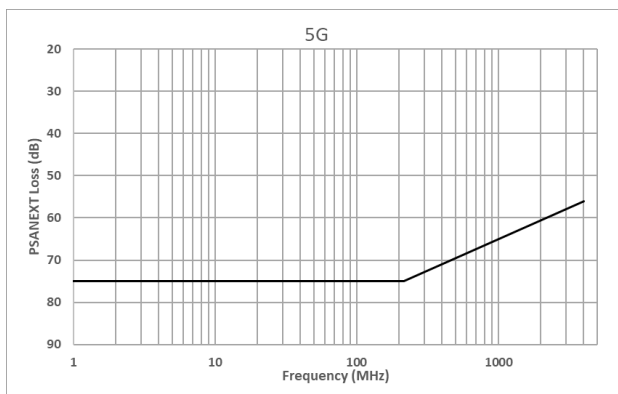
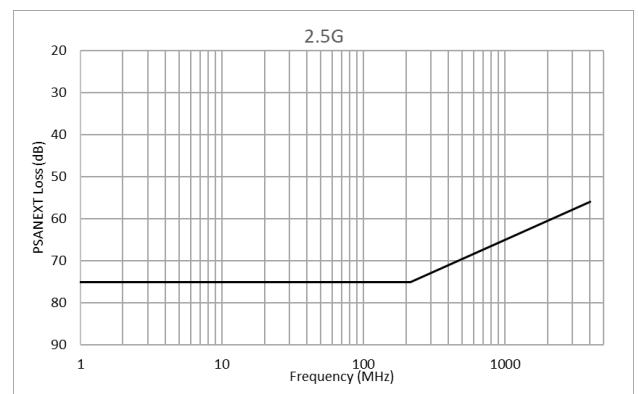
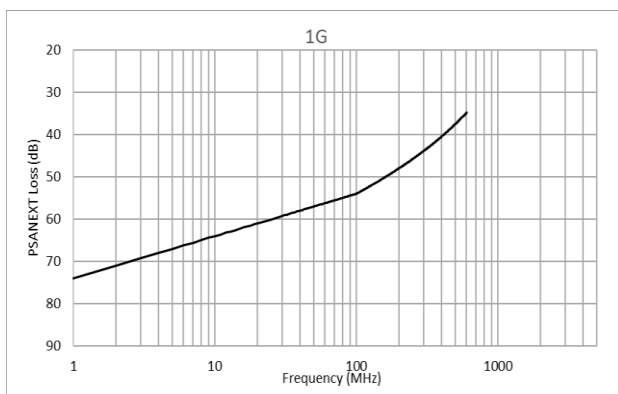

Figure 76: PSANEXT Loss requirements for WCC

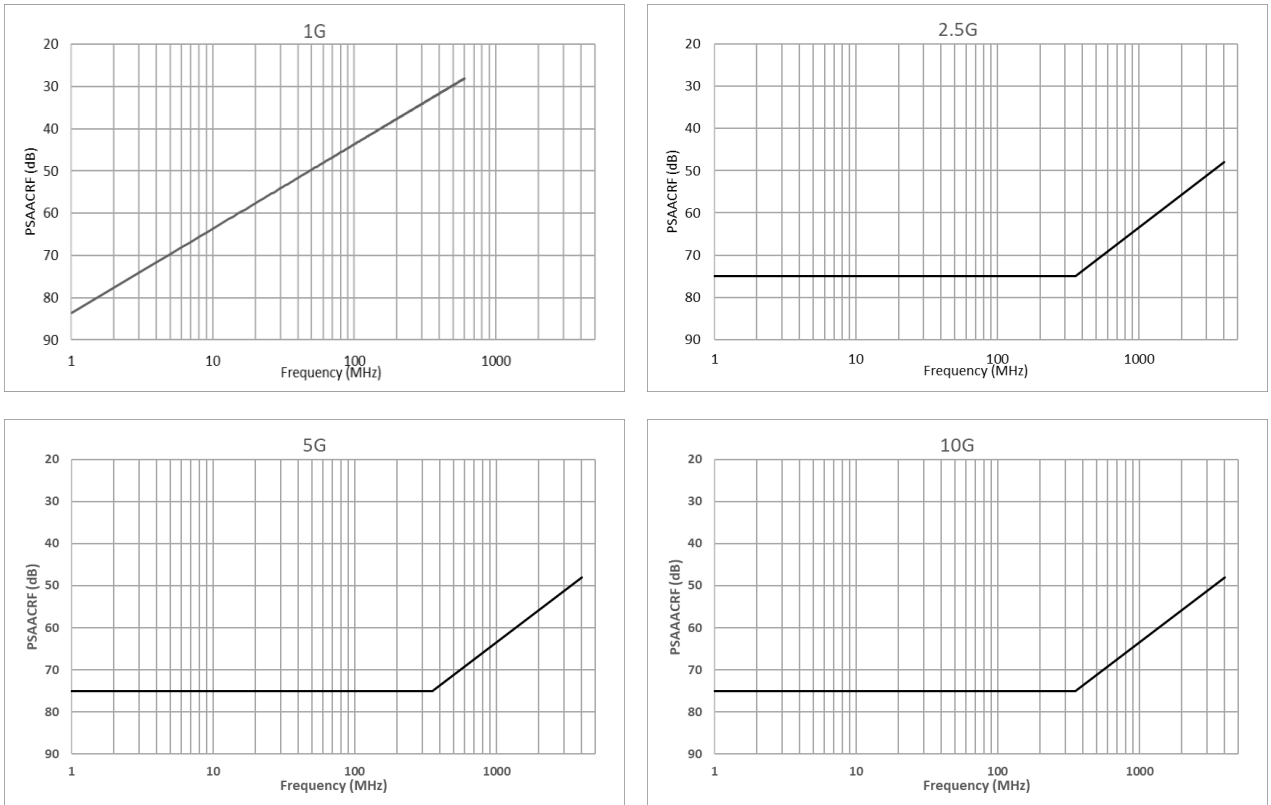

Figure 77: PSAACRF loss requirements for WCC

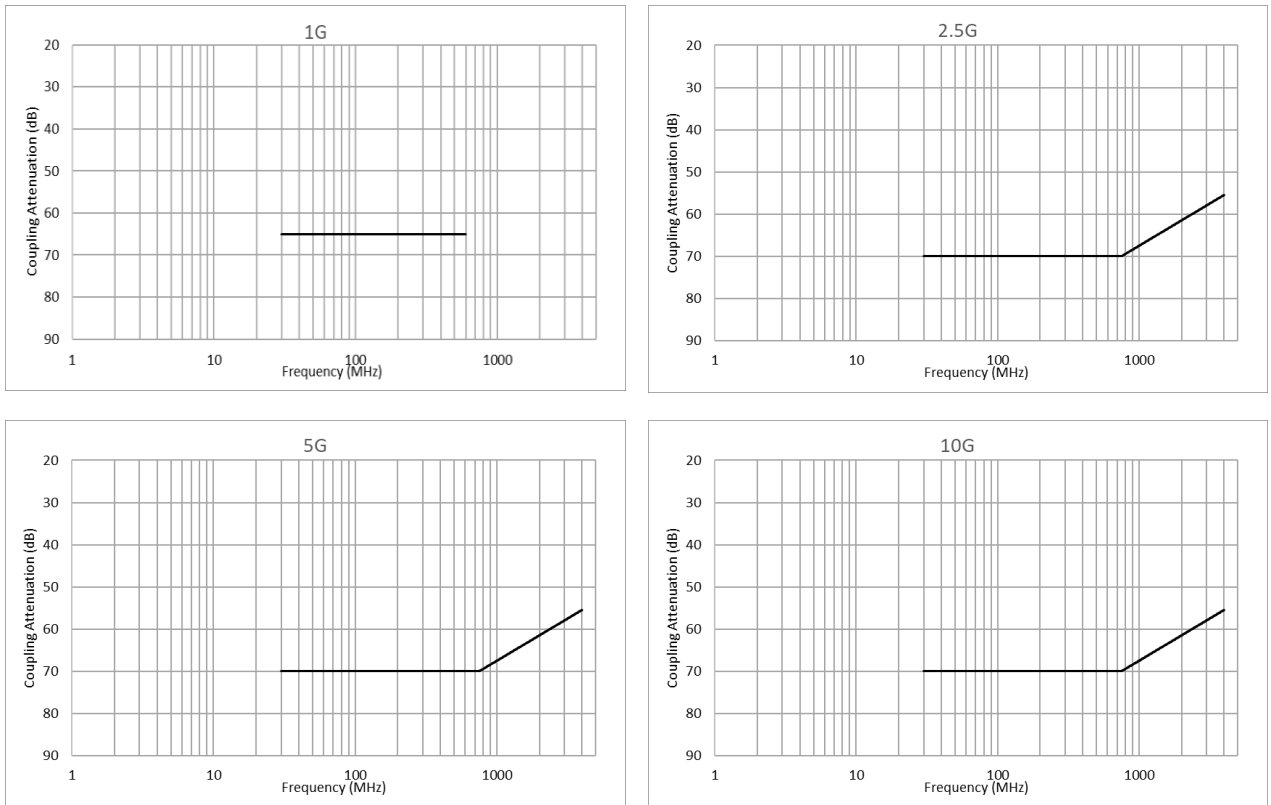

Figure 78: Coupling attenuation requirements for reference channel assemblies

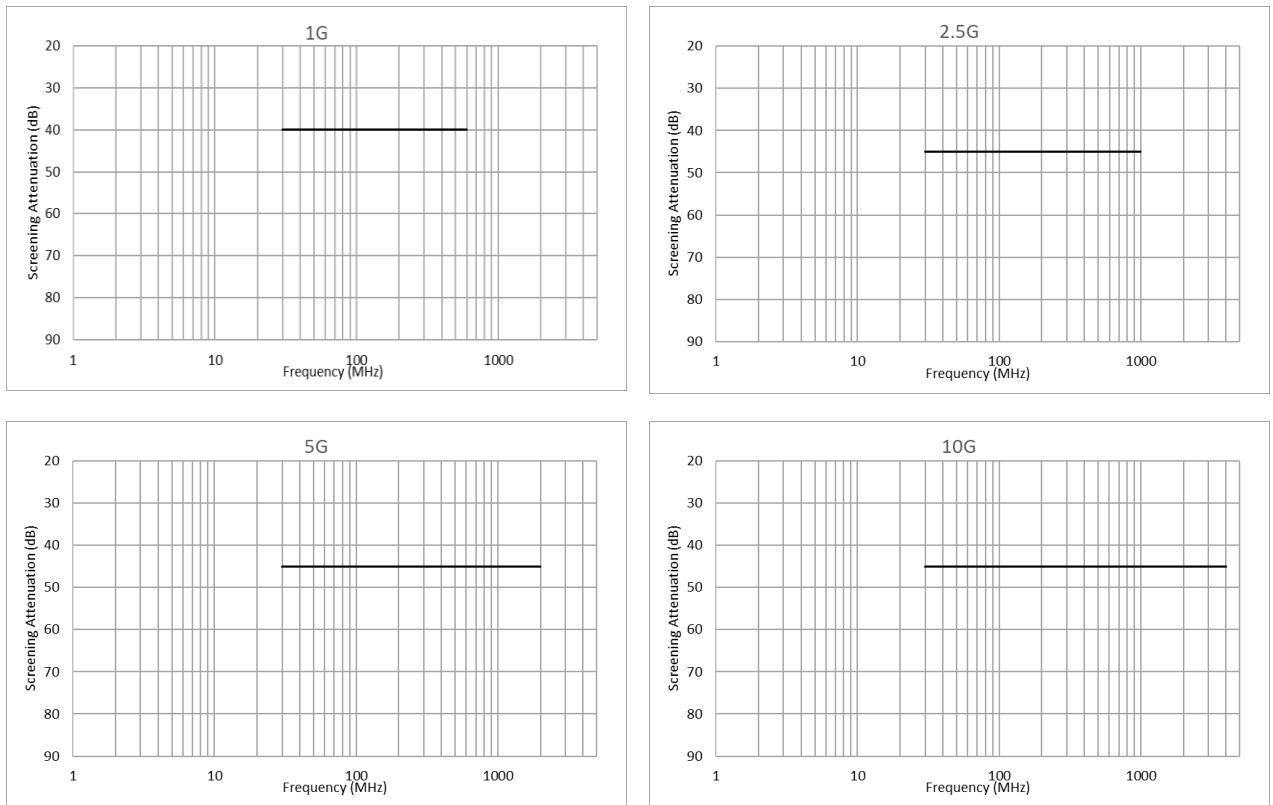

Figure 79: Screening attenuation requirements for the reference channel assemblies

Annex A (informative)

Additional Measurement Setup Definitions

A.1 Measurement Fixture Examples

Figure 80 shows an example of a pair of measurement fixtures.

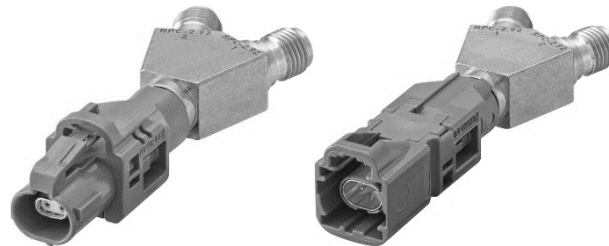

Figure 80: Measurement fixture for single port connectors, example

Figure 81 shown shows an example measurement fixture pair without housing, designed to fit into the ports of a multiport connector.

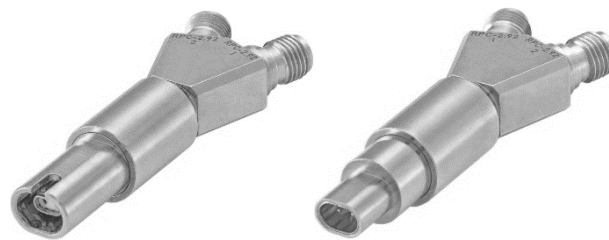

Figure 81: Measurement fixture for multiport connectors without housing, example

The connector measurement fixture shall provide optimum connection of the PCB connector with the measurement equipment. PCB based measurement fixtures with impedance-controlled traces should be used. The length of the traces should be kept as short as possible. Appropriate coaxial connectors and a 2X-Thru calibration line are recommended. An example of a PCB based connector measurement fixture with mated PCB connector in Figure 82.

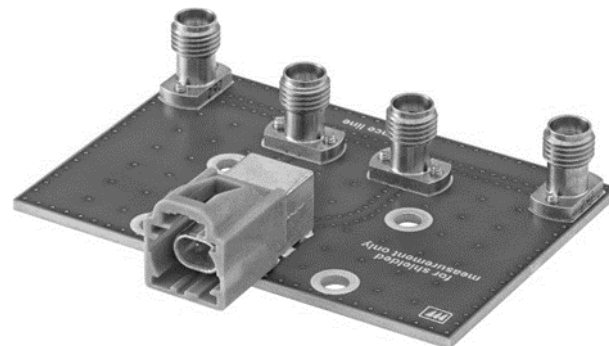

Figure 82: PCB based measurement fixture example

For multiport connectors, measurement fixtures with ground layers on bottom and top are recommended to reduce the crosstalk between pairs. An example of a PCB based multiport connector measurement fixture with 2X-Thru calibration line is shown in Figure 83.

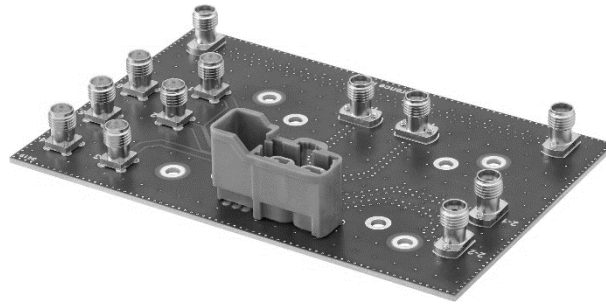

Figure 83: PCB based multiport connector measurement fixture example

Direct measurement fixtures can be used for cable measurements. Direct measurement fixtures need to provide a low impedance connection from the cable shield along the measurement fixture to the outer conductor of the coaxial connectors. Figure 84 shows an example of a direct measurement fixture, where the cable conductors are clamped for ease of handling.

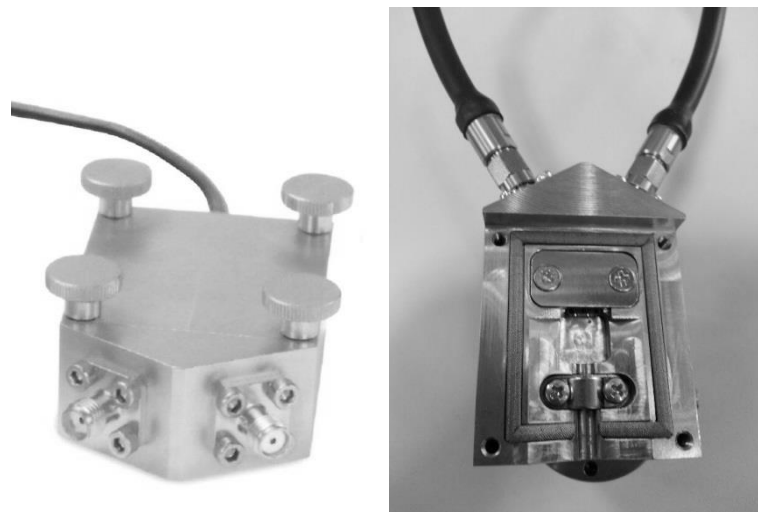

Figure 84: Direct measurement fixture example

A.2 Coupling and Screening Attenuation Measurement Examples

The coupling and screening attenuation of connectors is measured in triaxial setup according to [5]. Figure 85 shows an example of the overall setup for coupling and screening attenuation measurements of connectors. The differential port of the VNA is connected to the DUT via measurement fixture and differential cable of the specified length by means of tube in tube method. The other side of the triaxial tube is connected to the single ended port of the VNA.

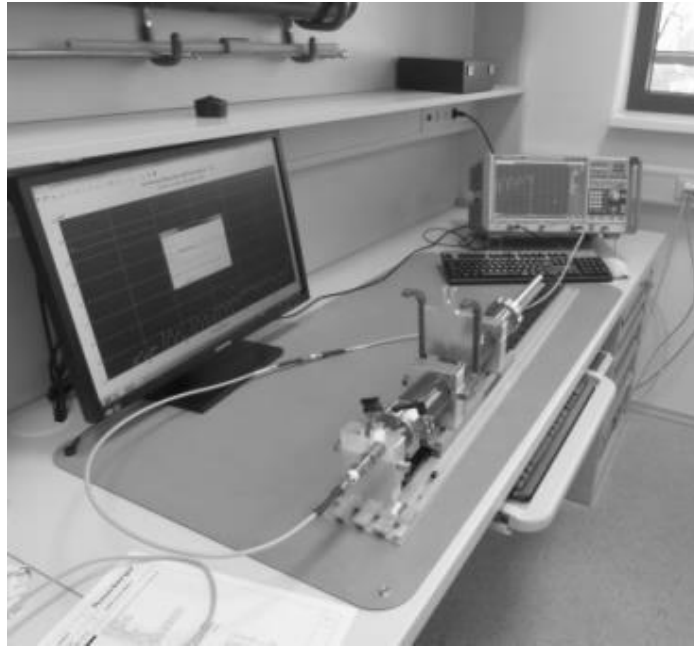

Figure 85: Connector coupling and screening attenuation measurement setup example

Figure 86 and Figure 87 show examples of mated PCB connectors under test.

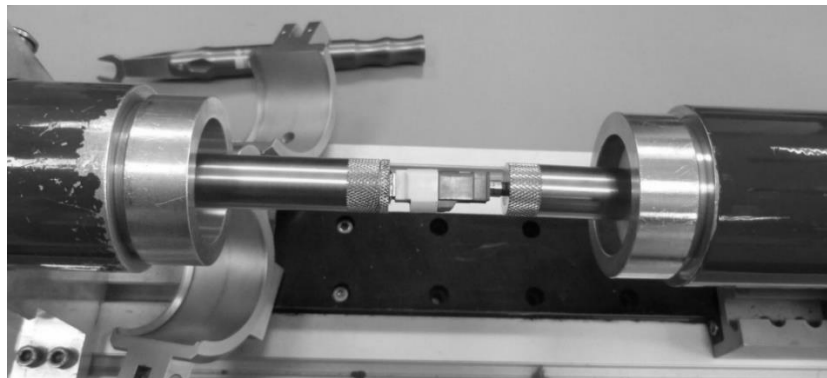

Figure 86: Connector coupling and screening attenuation measurement setup example for straight PCB connectors



Figure 87: Connector coupling and screening attenuation measurement setup example for right angled PCB connectors

The jacket of the cable is removed right next to the connector and clamps are used to provide a low impedance connection from the inner tube respectively the termination to the cable shield (Figure 88).

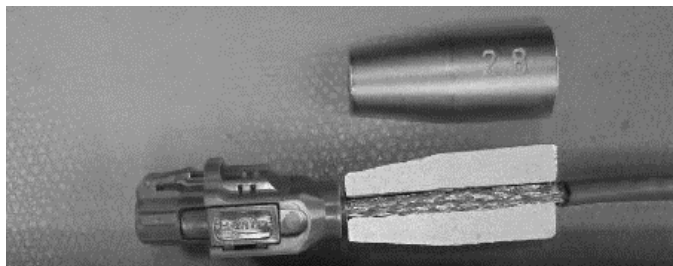

Figure 88: Inline and PCB connector shield contact preparation for coupling and screening attenuation measurement example

Figure 89 shows an example of a PCB connector under test with integrated termination.

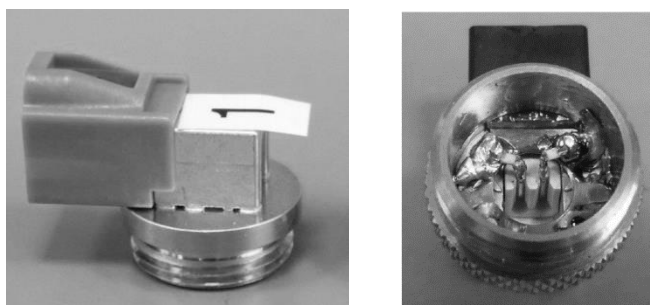

Figure 89: Right angled PCB connector under test with soldered termination loads

Figure 90 shows an example of a cable termination for cable coupling and screening attenuation measurement.

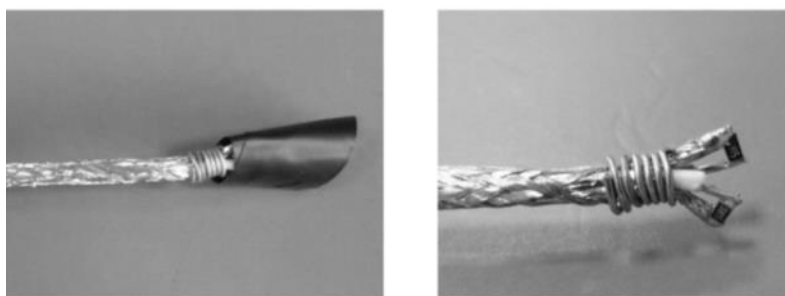

Figure 90: Cable coupling and screening attenuation measurement termination example

Figure 91 shows an ideally shielded termination load as used for cable connector or cable assembly coupling and screening attenuation measurements. The connector housing is directly connected to the termination load's shielding cap without any gaps.

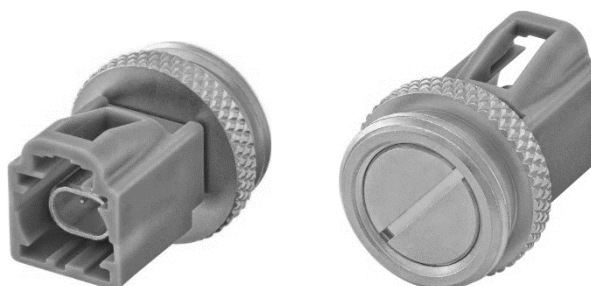

Figure 91: Ideally shielded triaxial termination load plug straight

Annex B (informative)

Reference Test Object Definitions

B.1 Reference Cable Assemblies

The reference cable assembly RCA1 has got a cable length of 3.5 m with cable connectors on each end as shown in Figure 92. This topology serves as common reference to compare cable assemblies in terms of their electrical properties. It also allows comparing measurement results from different test laboratories.

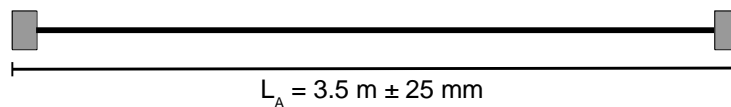

Figure 92: Reference cable assembly RCA1

B.2 Reference Communication Channels

The following communication channel topologies serve as common references to compare whole communication channels as combination of cable assemblies. It also allows to compare the results of different test houses. The reference communication channel RCC1 has got an overall length of 15 m, consisting of 5 cable assemblies with equal length of 3 m as shown in Figure 93. It serves as reference for testing long channels with the maximum allowed physical length and highest number of connectors.

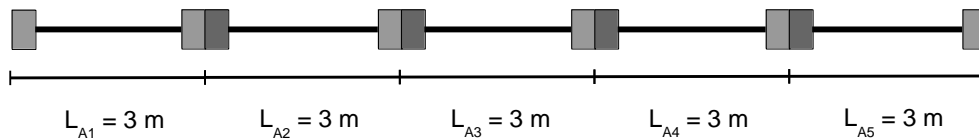

Figure 93: Reference communication channel RCC1, nominal length 15 m

The reference communication channel RCC2 as shown in Figure 94 has got a nominal length of 1.75 m, consisting of two cable assemblies including one mated pair of cable connectors (inline). The overall shall be between 1.7 m and 1.8 m. The nominal cable assembly lengths shall be 1.275 m and 0.475 m. It serves as representation for coupling and screening attenuation testing with at least one component of each type (cable, cable connector, PCB connector) in a communication channel.

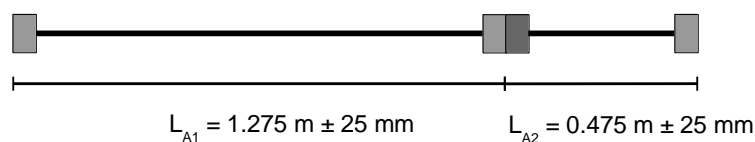

Figure 94: Reference communication channel RCC2, nominal length 1.75 m

The reference communication channel RCC3 has got a length of 0.5 m, consisting of two short cable assemblies shown in Figure 95. This communication channel serves as common reference for environmental and ageing tests on a DUT, that shall not be unmated during or between a test sequence. RCC3 corresponds to the mated connector pair test procedure in Section 6.1.1.

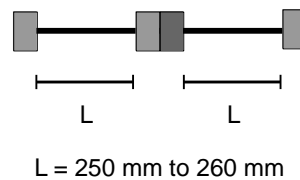

Figure 95: Reference communication channel RCC3

The reference communication channel RCC4 has got a length of 15 m, consisting of five cable assemblies is with the lengths as shown in Figure 96. This communication channel serves as common reference for the definition of component requirements for connectors and cable assemblies.

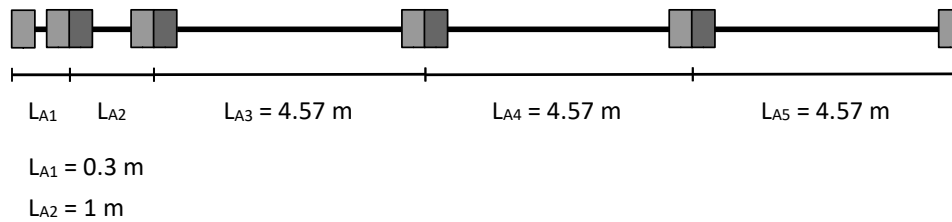

Figure 96: Reference communication channel RCC4, nominal length 15 m

B.3 Reference Wiring Harness

The channel assembly as described in this chapter serves as common reference to compare different components in terms of their electrical properties in the context of a whole wiring harness. It also allows comparing the results of different test houses. The reference wiring harness RWH was derived from a worst-case camera application scenario. It consists of a bundle of five cables in a 4 around 1 configuration as shown in Figure 97 and Figure 98. The total cable length of the bundled part of the wiring harness is 5 m including two equally spaced inline connectors, resulting in 1.66 m length for each cable segment. One communication channel is extended by two segments of 1.5 m length including one additional inline connector. This extended channel is centered in the four around one cable bundle arrangement shown in Figure 98.

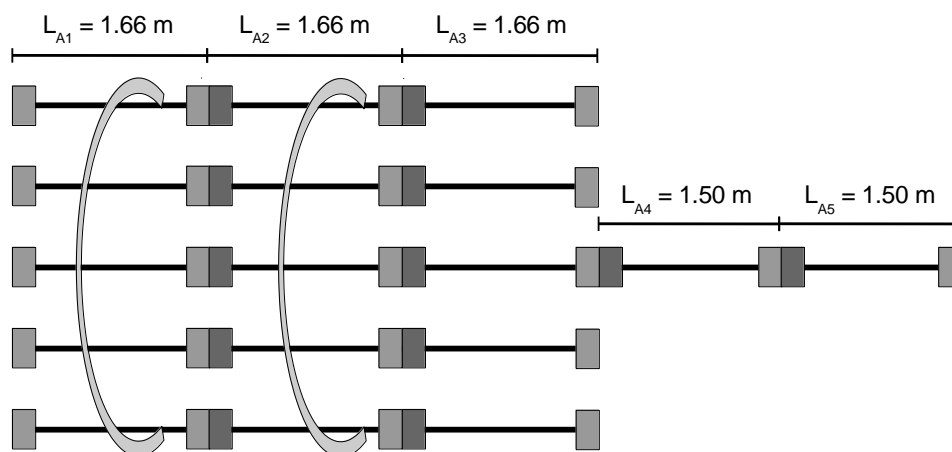

Figure 97: Reference wiring harness RWH cable bundling

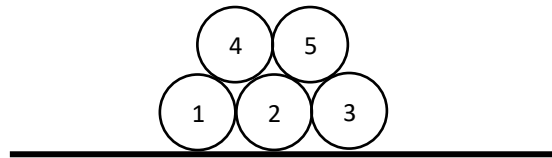

Figure 98: Four around one cable bundling

For each port, the crosstalk results to all other ports need to be summed. Equations how to calculate the power sum crosstalk from individual transmission measurements are given in Chapter 3.8.

Annex C (informative)

Measurement Setup for Detailed Cable Assembly Analysis

For detailed analysis of the connector to cable termination of cable assemblies, the following measurement setup is recommended. Cable assemblies are measured for return loss using measurement fixtures from both ends, that shall comply with the measurement fixture requirements in 5.2. The measurement of the whole cable assembly is carried out from calibration reference plane to calibration reference plane, without gating applied. Additionally, the gated return loss of both cable connectors is measured as described in the connector measurement setup (Chapter 6.1). The cable connector should comply with the connector RL requirements in 7.1.1. With this information, a detailed analysis of the electrical connector termination quality should be possible.

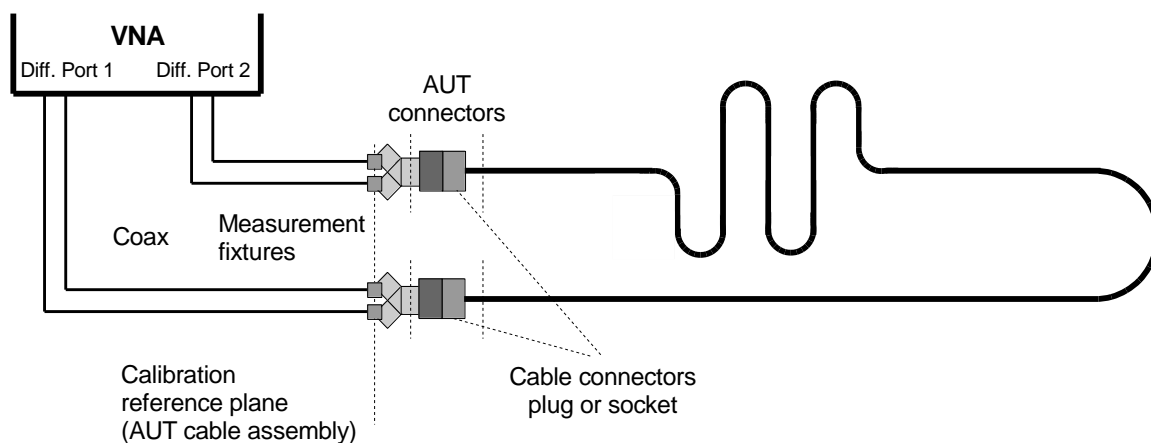

Figure 99: VNA measurement setup for detailed cable assembly analysis