

OPEN Alliance Automotive Ethernet ECU Test Specification Layer 2

TC8 ECU Test



Author & Company	Thomas Kirchmeier (BMW AG) Georg Janker (Ruetz System Solutions GmbH) All Members of the OPEN ALLIANCE TC8 Working Group
Title	OPEN Alliance Automotive Ethernet ECU Test Specification Layer 2
Version	3.0
Date	May 8, 2020
Status	final
Restriction Level	public

Version Control of Document

Version	Author	Description	Date
1.0	TC8 members	First release	15.01.2016
1.1	T.Kirchmeier (BMW)	Improvements regarding IPv4 test cases, see change history	31.05.2016
1.2	T.Kirchmeier (BMW)	Improvements regarding UDP test cases, see change history	29.06.2016
1.3	T.Kirchmeier (BMW)	Improvements regarding ICMPv4 test cases, see change history	07.09.2016
1.4	Mathias Kleinwächter (Ruetz System Solutions GmbH)	Chapter 5.6 DHCPv4 Server deleted	19.05.2017
1.4	Mathias Kleinwächter (Ruetz System Solutions GmbH)	Improvements regarding TCP test cases, see change history	23.05.2017
1.4	Mathias Kleinwächter (Ruetz System Solutions GmbH)	Added chapters 6.1.4 Specification of the SOMEIP TestStub Enhanced Testability Service (ETS) 6.1.6 Test Cases ETS Improvements regarding ARP test cases, see change history	24.05.2017
1.4	Georg Janker	Update of Layer 1 and Layer2 Chapters	24.05.2017
1.5	Georg Janker	Update of AUTOSAR References for SOME/IP to 1.1.0	30.05.2017
1.5	Georg Janker	Inserted Chapter: 3.6 Referenced TC 11 Tests	30.05.2017
1.6	Martin Heinzinger (Ruetz System Solutions GmbH)	Removed Port Disabling test and referenced to the corresponding TC11 Test	07.06.2017
1.7	Mathias Kleinwächter (Ruetz System Solutions GmbH)	Deleted invalid or duplicate Test Cases. See change history	20.06.2017
1.8	Frederic Garraud	Update 1.3 References	22.06.2017
1.9	Martin Heinzinger (Ruetz System Solutions GmbH)	Updated change history for L2 Switching	23.06.2017

OPEN Alliance

2.0	Mathias Kleinwächter (Ruetz System Solutions GmbH)	Release of final version 2.0	06.09.2017
3.0	Mathias Kleinwächter (Ruetz System Solutions GmbH)	Initial Version of separate Layer 2 document.	17.12.2019

Restriction level history of Document

Version	Restriction Level	Description	Date
1	OPEN Technical Members Only	Technical Members	25.10.2019

Contents

Foreword (Disclaimer)	5
Introduction	6
1 Scope (mandatory).....	7
2 Normative references (mandatory).....	7
3 Terms and Definitions (mandatory).....	7
4 Change history between version 2 and 3	8
5 Test Scope Layer 2 of Automotive Ethernet	9
5.1 Overview & Requirements for ECU Automotive Ethernet Switch Testing Test Scope	9
5.2 Test Setup	10
5.2.1 Standard test setup for switching	10
5.2.2 Switching test setup for triggered time measurements	11
5.3 VLAN Testing	12
5.4 General.....	29
5.5 Address Learning.....	36
5.6 Filtering of incoming frames	54
5.7 Time synchronization	65
5.8 Quality of Service	66
5.9 Configuration	70

Foreword (Disclaimer)

OPEN Alliance: Members Only/OPEN Internal OPEN Specification

OPEN Alliance CONFIDENTIAL

Copyright Notice and Disclaimer

OPEN Alliance members whose contributions were incorporated in the OPEN Specification (the “Contributing Members”) own the copyrights in the OPEN Specification, and permit the use of this OPEN Specification as follows:

OPEN ALLIANCE MEMBERS: Members of OPEN Alliance have the right to use this OPEN Specification, subject to the Member’s continued compliance with the OPEN Alliance governance documents, Intellectual Property Rights Policy, and the applicable OPEN Alliance Promoter or Adopter Agreement; and

NON-MEMBERS OF OPEN ALLIANCE: Use of the OPEN Specification by anyone who is not a Member of OPEN Alliance is prohibited.

The receipt of an OPEN Specification shall not operate as an assignment or license under any patent, industrial design, trademark, or other rights as may subsist in or be contained in or reproduced in any OPEN Specification. The implementation of this OPEN Specification will require such a license.

THIS OPEN SPECIFICATION IS PROVIDED ON AN “AS IS” BASIS AND ALL WARRANTIES, EITHER EXPLICIT OR IMPLIED, ARE EXCLUDED UNLESS MANDATORY UNDER LAW. ACCORDINGLY, THE OPEN ALLIANCE AND THE CONTRIBUTING MEMBERS MAKE NO REPRESENTATIONS OR WARRANTIES WITH REGARD TO THE OPEN SPECIFICATION OR THE INFORMATION (INCLUDING ANY SOFTWARE) CONTAINED THEREIN, INCLUDING ANY WARRANTIES OF MERCHANTABILITY, FITNESS FOR PURPOSE, OR ABSENCE OF THIRD PARTY RIGHTS AND MAKE NO REPRESENTATIONS AS TO THE ACCURACY OR COMPLETENESS OF THE OPEN SPECIFICATION OR ANY INFORMATION CONTAINED THEREIN.

THE OPEN ALLIANCE AND CONTRIBUTING MEMBERS ARE NOT LIABLE FOR ANY LOSSES, COSTS, EXPENSES OR DAMAGES ARISING IN ANY WAY OUT OF USE OR RELIANCE UPON THE OPEN SPECIFICATION OR ANY INFORMATION THEREIN. NOTHING IN THIS DOCUMENT OPERATES TO LIMIT OR EXCLUDE ANY LIABILITY FOR FRAUD OR ANY OTHER LIABILITY WHICH IS NOT PERMITTED TO BE EXCLUDED OR LIMITED BY OPERATION OF LAW.

Without prejudice to the foregoing, the OPEN Specification was developed for automotive applications only. The OPEN Specification has neither been developed, nor tested for non-automotive applications.

OPEN Alliance reserves the right to withdraw, modify, or replace any OPEN Specification at any time, without notice.

Introduction

This ECU and Network Test Specification is designed to determine if a product conforms to specifications defined in OPEN Specifications or related requirements. This specification is a collection of all test cases which are recommend to be considered for automotive use and should be referred by car manufacturers within their quality control processes.

Successful execution and passing all relevant tests gives a Device Under Test (DUT) a minimum approval that the device's basic implementations are done correctly.

This Test specification document is grouped in several chapters oriented on the scopes: "Automotive Ethernet", "TCP/IP Protocol Family" and "Automotive Protocols" which are described in chapter 1.3. Tests are organized and identified with distinct IDs that relate to their scopes, and a unique enumeration. For every scope introduction chapters explain common requirements on the Device under Test, the Test Setup and parameters used by the following tests.

1 Scope (mandatory)

Scope Automotive Ethernet includes the following ISO/OSI layers:

- Layer 2: Data Link Layer, e.g IEEE Ethernet MAC + VLAN (802.1Q), ARP

2 Normative references (mandatory)

The following documents are referred to in the text in such a way that some or all of their content constitutes requirements of this document. For dated references, only the edition cited applies. For undated references, the latest edition of the referenced document (including any amendments) applies.

[1] OA_100BASE-T1 Interoperability Test Suite 1v0

[2] IEEE Std 802.3bw™ – 2015 Amendment 1: Physical Layer Specifications and Management Parameters for 100 Mb/s Operation over a Single Balanced Twisted Pair Cable (100BASE-T1)..

[3] IEEE 100BASE-T1 Physical Media Attachment Test Suite Version 1.0

[4] IEEE 100BASE-T1 Definitions for Communication Channel, Version 1.0 .

[5] IEEE 100BASE-T1 EMC Test Specification for Transceivers Version 1v0

3 Terms and Definitions (mandatory)

No terms and definitions are listed in this document.

4 Change history between version 2 and 3

Test case ID	Change reason	Version 2	Version 3
--------------	------------------	-----------	-----------

5 Test Scope Layer 2 of Automotive Ethernet

5.1 Overview & Requirements for ECU Automotive Ethernet Switch Testing Test Scope

The tests in this scope validate the behavior of the “Automotive Ethernet Switch” within the ECU. The “Automotive Ethernet Switch” is an entity that includes the switch silicon hardware and any additional hardware, firmware, and software needed to meet the requirements for a “MAC bridge” set forth in the IEEE 802.1 standards.

Any reference to “DUT” in this test scope refers to the logical “Automotive Ethernet Switch” including any software or configuration done in an MCU or CPU. The “test device” shall include both externally connected hardware/software as well as software running on any MCU / CPU on the ECU that is connected to the “Automotive Ethernet Switch” via an Automotive Ethernet Port.

The tests in this test scope are designed to test that the “Automotive Ethernet Switch” entity is configured & operating correctly as per the ECU configuration, but assume that the functionality of the switch silicon, PHYs, or other components has been verified elsewhere.

The test cases are grouped by functional areas. Only those functional areas and test cases that are applicable to a given ECU need to be tested. The configuration of each ECU (including the switch configuration) should be used to determine which test cases are applicable.

5.2 Test Setup

5.2.1 Standard test setup for switching

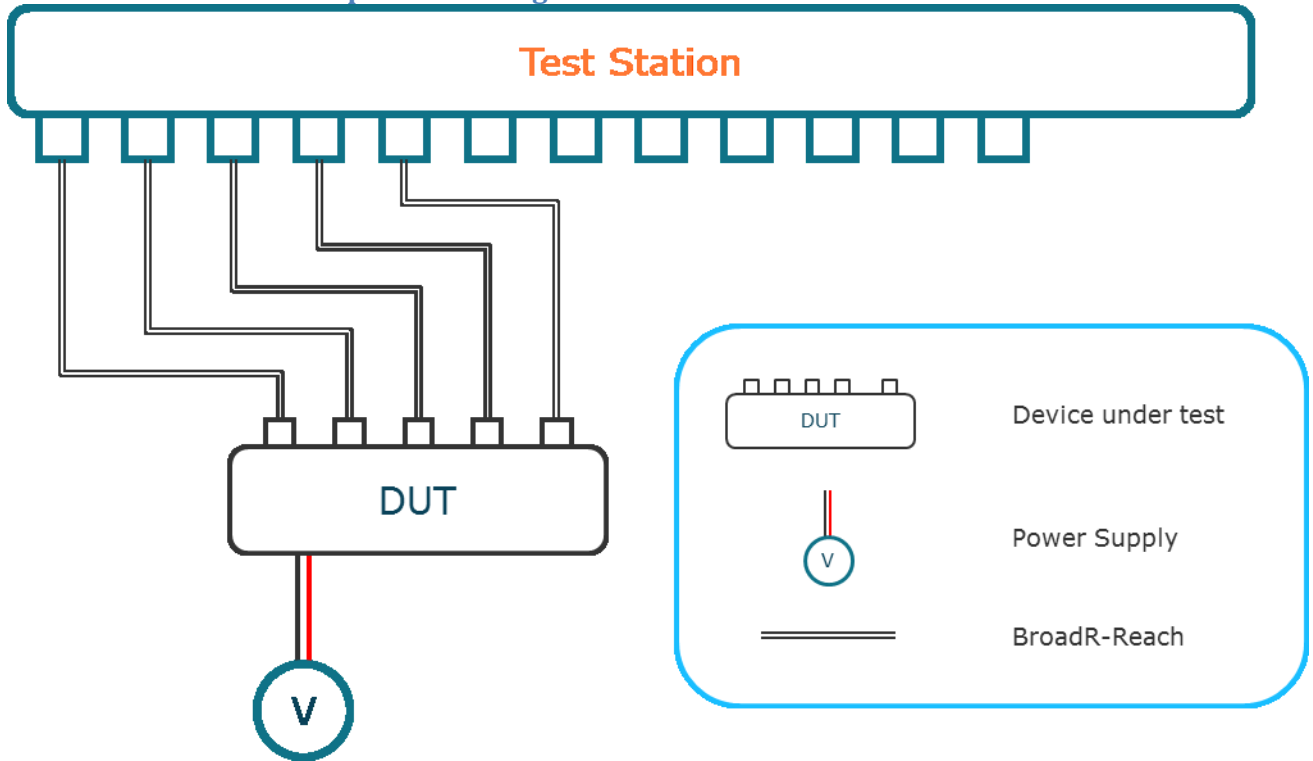

Figure 1: 5.2.1 Standard test setup for switching

5.2.2 Switching test setup for triggered time measurements

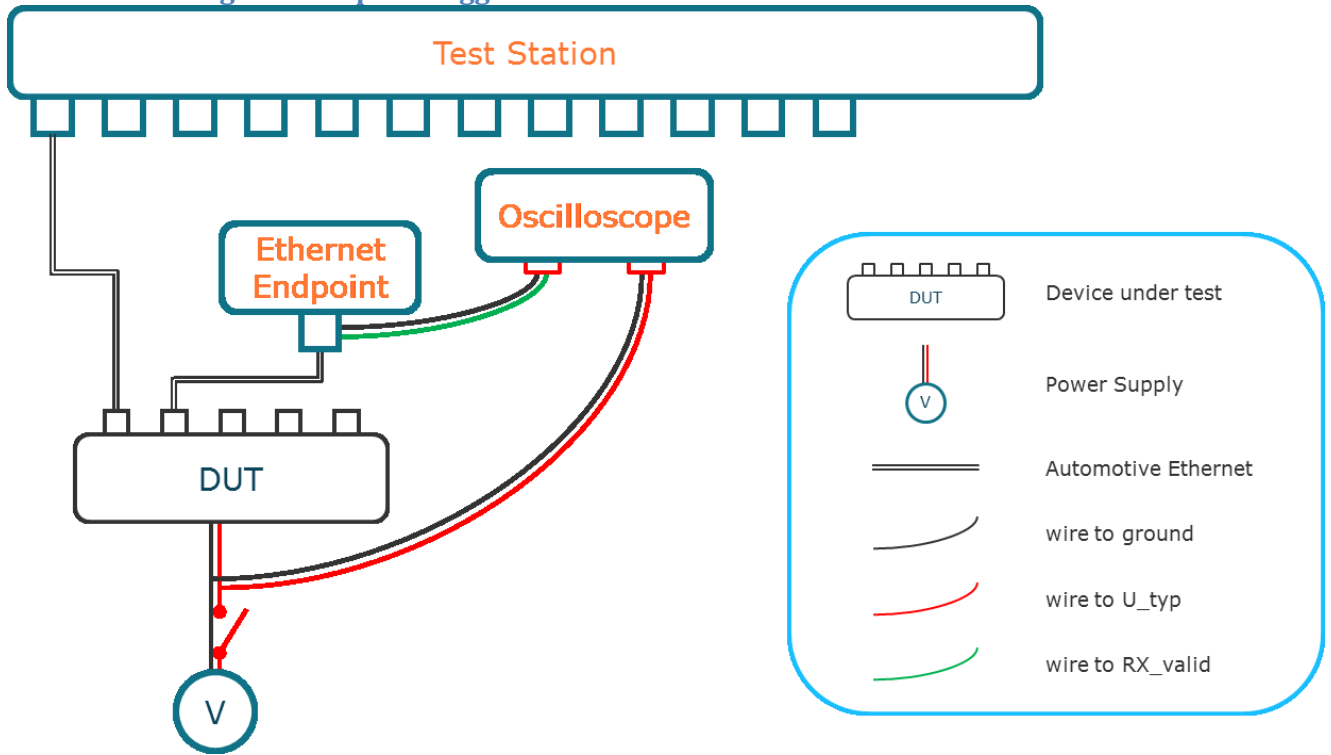

Figure 2: 5.2.2 Switching test setup for triggered time measurements

5.3 VLAN Testing

5.3.1.1.1 SWITCH_VLAN_X001: VLAN_untagged_external

Synopsis	Check if untagged frames are dropped or forwarded to external ports according to the customer's VLAN requirements.
Prerequisites	n/a
Test setup	Standard test setup for switching
Test Input Parameters	VLAN configuration
Test Procedure	<ol style="list-style-type: none"> 1. From the test station, send untagged broadcast frames to every DUT port. 2. On every test station port, check if the frames are received as expected according to the customer's VLAN requirements.
Pass Criteria	<ol style="list-style-type: none"> 2. Every frame sent from the test station that is expected to be forwarded according to the customer's VLAN requirements has been received at the expected test station ports. 2. No frame that is not expected to be forwarded according to the customer's VLAN requirements has been received at any unexpected test station ports. 2. Every frame received at the test station is untagged, single-tagged or double-tagged, respectively, according to the customer's VLAN requirements. 2. Every single-tagged or double-tagged frame carries the correct inner and/or outer TPID and the correct VIDs according to the customer's VLAN requirements.
Reference	802.1Q-2018
Notes	n/a

5.3.1.1.2 SWITCH_VLAN_X002: VLAN_single-tagged_external

Synopsis	Check if single-tagged frames are dropped or forwarded to external ports according to the customer's VLAN requirements.
Prerequisites	n/a
Test setup	Standard test setup for switching
Test Input Parameters	VLAN configuration

Test Procedure	<ol style="list-style-type: none"> 1. From the test station, send single-tagged broadcast frames to every DUT port. The TPID shall be 0x8100. The test station shall iterate through every VID for every combination of ingress and egress port, including VID 0 and VID 4095. 2. On every test station port, check if the frames are received as expected according to the customer's VLAN requirements.
Pass Criteria	<ol style="list-style-type: none"> 2. Every frame sent from the test station that is expected to be forwarded according to the customer's VLAN requirements has been received at the expected test station ports. 2. No frame that is not expected to be forwarded according to the customer's VLAN requirements has been received at any unexpected test station ports. 2. Every frame received at the test station is untagged, single-tagged or double-tagged, respectively, according to the customer's VLAN requirements. 2. Every single-tagged or double-tagged frame carries the correct inner and/or outer TPID and the correct VIDs according to the customer's VLAN requirements.
Reference	802.1Q-2018
Notes	n/a

5.3.1.1.3 SWITCH_VLAN_X003: VLAN_regular_double-tagged_outer_TPID_0x88a8_external

Synopsis	Check if regularly double-tagged frames with outer TPID 0x88a8 are dropped or forwarded to external ports according to the customer's VLAN requirements.
Prerequisites	n/a
Test setup	Standard test setup for switching
Test Input Parameters	VLAN configuration
Test Procedure	<ol style="list-style-type: none"> 1. From the test station, send double-tagged broadcast frames to every DUT port. The inner TPID shall be 0x8100. The outer TPID shall be 0x88a8. The VID of the inner and outer tag shall be the same. The test station shall iterate through every VID for every combination of ingress and egress port, including VID 0 and VID 4095. 2. On every test station port, check if the frames are received as expected according to the customer's VLAN requirements.
Pass Criteria	<ol style="list-style-type: none"> 2. Every frame sent from the test station that is expected to be forwarded according to the customer's VLAN requirements has been received at the expected test station ports.

	<p>2. No frame that is not expected to be forwarded according to the customer's VLAN requirements has been received at any unexpected test station ports.</p> <p>2. Every frame received at the test station is untagged, single-tagged or double-tagged, respectively, according to the customer's VLAN requirements.</p> <p>2. Every single-tagged or double-tagged frame carries the correct inner and/or outer TPID and the correct VID's according to the customer's VLAN requirements.</p>
Reference	802.1Q-2018
Notes	n/a

5.3.1.1.4 SWITCH_VLAN_X004: VLAN_regular_double-tagged_outer_TPID_0x9100_external

Synopsys	Check if regularly double-tagged frames with outer TPID 0x9100 are dropped or forwarded to external ports according to the customer's VLAN requirements.
Prerequisites	n/a
Test setup	Standard test setup for switching
Test Input Parameters	VLAN configuration
Test Procedure	<ol style="list-style-type: none"> From the test station, send double-tagged broadcast frames to every DUT port. The inner TPID shall be 0x8100. The outer TPID shall be 0x9100. The VID of the inner and outer tag shall be the same. The test station shall iterate through every VID for every combination of ingress and egress port, including VID 0 and VID 4095. On every test station port, check if the frames are received as expected according to the customer's VLAN requirements.
Pass Criteria	<p>2. Every frame sent from the test station that is expected to be forwarded according to the customer's VLAN requirements has been received at the expected test station ports.</p> <p>2. No frame that is not expected to be forwarded according to the customer's VLAN requirements has been received at any unexpected test station ports.</p> <p>2. Every frame received at the test station is untagged, single-tagged or double-tagged, respectively, according to the customer's VLAN requirements.</p> <p>2. Every single-tagged or double-tagged frame carries the correct inner and/or outer TPID and the correct VID's according to the customer's VLAN requirements.</p>

Reference	802.1Q-2018
Notes	n/a

5.3.1.1.5 SWITCH_VLAN_X005: VLAN_irregular_double-tagged_double_inner_external

Synopsis	Verify that irregularly double-tagged frames with two TPIDs 0x8100 are not forwarded to external ports.
Prerequisites	n/a
Test setup	Standard test setup for switching
Test Input Parameters	VLAN configuration
Test Procedure	<ol style="list-style-type: none"> From the test station, send double-tagged broadcast frames to every DUT port. The inner TPID shall be 0x8100. The outer TPID shall be 0x8100. The VID of the inner and outer tag shall be the same. The test station shall iterate through every VID for every combination of ingress and egress port, including VID 0 and VID 4095. On every test station port, check if the frames are received as expected according to the customer's VLAN requirements.
Pass Criteria	2. The test station does not receive any of the frames sent in step 1 from any DUT port.
Reference	802.1Q-2018
Notes	n/a

5.3.1.1.6 SWITCH_VLAN_X006: VLAN_irregular_double-tagged_inner_first_outer_TPID_0x88a8_external

Synopsis	Verify that irregularly double-tagged frames with outer TPID 0x8100 and inner TPID 0x88a8 are not forwarded to external ports.
Prerequisites	n/a
Test setup	Standard test setup for switching
Test Input Parameters	VLAN configuration
Test Procedure	<ol style="list-style-type: none"> From the test station, send double-tagged broadcast frames to every DUT port. The inner TPID shall be 0x88a8. The outer TPID shall be 0x8100. The VID of the inner and outer tag shall be the same. The test station shall

	<p>iterate through every VID for every combination of ingress and egress port, including VID 0 and VID 4095.</p> <p>2. On every test station port, check if the frames are received as expected according to the customer's VLAN requirements.</p>
Pass Criteria	2. The test station does not receive any of the frames sent in step 1 from any DUT port.
Reference	802.1Q-2018
Notes	n/a

5.3.1.1.7 SWITCH_VLAN_X007: VLAN_irregular_double-tagged_inner_first_outer_TPID_0x9100_external

Synopsis	Verify that irregularly double-tagged frames with outer TPID 0x8100 and inner TPID 0x9100 are not forwarded to external ports.
Prerequisites	n/a
Test setup	Standard test setup for switching
Test Input Parameters	VLAN configuration
Test Procedure	<p>1. From the test station, send double-tagged broadcast frames to every DUT port. The inner TPID shall be 0x9100. The outer TPID shall be 0x8100. The VID of the inner and outer tag shall be the same. The test station shall iterate through every VID for every combination of ingress and egress port, including VID 0 and VID 4095.</p> <p>2. On every test station port, check if the frames are received as expected according to the customer's VLAN requirements.</p>
Pass Criteria	2. The test station does not receive any of the frames sent in step 1 from any DUT port.
Reference	802.1Q-2018
Notes	n/a

5.3.1.1.8 SWITCH_VLAN_X008: VLAN_untagged_internal_ICMP

Synopsis	Check if untagged frames are dropped or forwarded to internal ports according to the customer's VLAN requirements by using ICMP Echo Request messages.
Prerequisites	n/a

Test setup	Standard test setup for switching
Test Input Parameters	VLAN configuration
Test Procedure	<ol style="list-style-type: none"> 1. From the test station, send untagged unicast ICMP Echo Request frames to every DUT port. For the destination MAC and IP addresses of the frames, the test station shall iterate through the addresses of all internal microcontrollers of the ECU. 2. On every test station port, check if ICMP Echo Reply frames are received as expected according to the customer's VLAN requirements.
Pass Criteria	<p>2. For every transmitted ICMP Echo Request frame for which a reply from an internal host controller is expected according to the customer's VLAN requirements, an ICMP Echo Reply been received at the expected test station ports.</p> <p>2. For no transmitted ICMP Echo Request frame for which no reply from an internal host controller is expected according to the customer's VLAN requirements, an ICMP Echo Reply been received at the expected test station ports.</p> <p>2. Every ICMP Echo Reply frame received at the test station is untagged, single-tagged or double-tagged, respectively, according to the customer's VLAN requirements.</p> <p>2. Every single-tagged or double-tagged ICMP Echo Reply frame carries the correct inner and/or outer TPID and the correct VIDs according to the customer's VLAN requirements.</p>
Reference	802.1Q-2018
Notes	n/a

5.3.1.1.9 SWITCH_VLAN_X009: VLAN_single-tagged_internal_ICMP

Synopsis	Check if untagged frames are dropped or forwarded to internal ports according to the customer's VLAN requirements by using ICMP Echo Request messages.
Prerequisites	n/a
Test setup	Standard test setup for switching
Test Input Parameters	VLAN configuration
Test Procedure	<ol style="list-style-type: none"> 1. From the test station, send single-tagged unicast ICMP Echo Request frames to every DUT port. For the destination MAC and IP addresses of the

	<p>frames, the test station shall iterate through the addresses of all internal microcontrollers of the ECU.</p> <p>2. On every test station port, check if ICMP Echo Reply frames are received as expected according to the customer's VLAN requirements.</p>
Pass Criteria	<p>2. For every transmitted ICMP Echo Request frame for which a reply from an internal host controller is expected according to the customer's VLAN requirements, an ICMP Echo Reply been received at the expected test station ports.</p> <p>2. For no transmitted ICMP Echo Request frame for which no reply from an internal host controller is expected according to the customer's VLAN requirements, an ICMP Echo Reply been received at the expected test station ports.</p> <p>2. Every ICMP Echo Reply frame received at the test station is untagged, single-tagged or double-tagged, respectively, according to the customer's VLAN requirements.</p> <p>2. Every single-tagged or double-tagged ICMP Echo Reply frame carries the correct inner and/or outer TPID and the correct VIDs according to the customer's VLAN requirements.</p>
Reference	802.1Q-2018
Notes	n/a

5.3.1.1.10 SWITCH_VLAN_X010: VLAN_regular_double-tagged_outer_TPID_0x88a8_internal_ICMP

Synopsis	Check if regularly double-tagged frames with outer TPID 0x88a8 are dropped or forwarded to internal ports according to the customer's VLAN requirements by using ICMP Echo Request messages.
Prerequisites	The DUT is capable of responding to ICMP Echo Request messages.
Test setup	Standard test setup for switching
Test Input Parameters	VLAN configuration
Test Procedure	<p>1. From the test station, send double-tagged unicast ICMP Echo Request frames to every DUT port. For the destination MAC and IP addresses of the frames, the test station shall iterate through the addresses of all internal microcontrollers of the ECU. The inner TPID shall be 0x8100. The outer TPID shall be 0x88a8. The VID of the inner and outer tag shall be the same. The test station shall iterate through every VID for every combination of ingress and egress port, including VID 0 and VID 4095.</p>

	<p>2. On every test station port, check if ICMP Echo Reply frames are received as expected according to the customer's VLAN requirements.</p>
Pass Criteria	<p>2. For every transmitted ICMP Echo Request frame for which a reply from an internal host controller is expected according to the customer's VLAN requirements, an ICMP Echo Reply been received at the expected test station ports.</p> <p>2. For no transmitted ICMP Echo Request frame for which no reply from an internal host controller is expected according to the customer's VLAN requirements, an ICMP Echo Reply been received at the expected test station ports.</p> <p>2. Every ICMP Echo Reply frame received at the test station is untagged, single-tagged or double-tagged, respectively, according to the customer's VLAN requirements.</p> <p>2. Every single-tagged or double-tagged ICMP Echo Reply frame carries the correct inner and/or outer TPID and the correct VIDs according to the customer's VLAN requirements.</p>
Reference	802.1Q-2018
Notes	n/a

5.3.1.1.11 SWITCH_VLAN_X011: VLAN_regular_double-tagged_outer_TPID_0x9100_internal_ICMP

Synopsis	Check if regularly double-tagged frames with outer TPID 0x9100 are dropped or forwarded to internal ports according to the customer's VLAN requirements by using ICMP Echo Request messages.
Prerequisites	The DUT is capable of responding to ICMP Echo Request messages.
Test setup	Standard test setup for switching
Test Input Parameters	VLAN configuration
Test Procedure	<ol style="list-style-type: none"> 1. From the test station, send double-tagged unicast ICMP Echo Request frames to every DUT port. For the destination MAC and IP addresses of the frames, the test station shall iterate through the addresses of all internal microcontrollers of the ECU. The inner TPID shall be 0x8100. The outer TPID shall be 0x9100. The VID of the inner and outer tag shall be the same. The test station shall iterate through every VID for every combination of ingress and egress port, including VID 0 and VID 4095. 2. On every test station port, check if ICMP Echo Reply frames are received as expected according to the customer's VLAN requirements.

Pass Criteria	<p>2. For every transmitted ICMP Echo Request frame for which a reply from an internal host controller is expected according to the customer's VLAN requirements, an ICMP Echo Reply been received at the expected test station ports.</p> <p>2. For no transmitted ICMP Echo Request frame for which no reply from an internal host controller is expected according to the customer's VLAN requirements, an ICMP Echo Reply been received at the expected test station ports.</p> <p>2. Every ICMP Echo Reply frame received at the test station is untagged, single-tagged or double-tagged, respectively, according to the customer's VLAN requirements.</p> <p>2. Every single-tagged or double-tagged ICMP Echo Reply frame carries the correct inner and/or outer TPID and the correct VID according to the customer's VLAN requirements.</p>
Reference	802.1Q-2018
Notes	n/a

5.3.1.1.12 SWITCH_VLAN_X012: VLAN_irregular_double-tagged_double_inner_internal_ICMP

Synopsis	Verify that irregularly double-tagged frames with two TPIDs 0x8100 are not forwarded to internal ports by using ICMP Echo Request messages.
Prerequisites	The DUT is capable of responding to ICMP Echo Request messages.
Test setup	Standard test setup for switching
Test Input Parameters	VLAN configuration
Test Procedure	<ol style="list-style-type: none"> 1. From the test station, send double-tagged unicast ICMP Echo Request frames to every DUT port. For the destination MAC and IP addresses of the frames, the test station shall iterate through the addresses of all internal microcontrollers of the ECU. The inner TPID shall be 0x8100. The outer TPID shall be 0x8100. The VID of the inner and outer tag shall be the same. The test station shall iterate through every VID for every combination of ingress and egress port, including VID 0 and VID 4095. 2. On every test station port, check if ICMP Echo Reply frames are received as expected according to the customer's VLAN requirements.
Pass Criteria	2. For every transmitted ICMP Echo Request frame for which a reply from an internal host controller is expected according to the customer's VLAN

	<p>requirements, an ICMP Echo Reply been received at the expected test station ports.</p> <p>2. For no transmitted ICMP Echo Request frame for which no reply from an internal host controller is expected according to the customer's VLAN requirements, an ICMP Echo Reply been received at the expected test station ports.</p> <p>2. Every ICMP Echo Reply frame received at the test station is untagged, single-tagged or double-tagged, respectively, according to the customer's VLAN requirements.</p> <p>2. Every single-tagged or double-tagged ICMP Echo Reply frame carries the correct inner and/or outer TPID and the correct VID according to the customer's VLAN requirements.</p>
Reference	802.1Q-2018
Notes	n/a

5.3.1.1.13 SWITCH_VLAN_X013: VLAN_irregular_double-tagged_inner_first_outer_TPID_0x88a8_internal_ICMP

Synopsis	Verify that irregularly double-tagged frames with outer TPID 0x8100 and inner TPID 0x88a8 are not forwarded to internal ports using unicast ICMP Echo Request messages.
Prerequisites	The DUT is capable of responding to ICMP Echo Request messages.
Test setup	Standard test setup for switching
Test Input Parameters	VLAN configuration
Test Procedure	<ol style="list-style-type: none"> 1. From the test station, send double-tagged unicast ICMP Echo Request frames to every DUT port. For the destination MAC and IP addresses of the frames, the test station shall iterate through the addresses of all internal microcontrollers of the ECU. The inner TPID shall be 0x88a8. The outer TPID shall be 0x8100. The VID of the inner and outer tag shall be the same. The test station shall iterate through every VID for every combination of ingress and egress port, including VID 0 and VID 4095. 2. On every test station port, check if ICMP Echo Reply frames are received as expected according to the customer's VLAN requirements.
Pass Criteria	<ol style="list-style-type: none"> 2. For every transmitted ICMP Echo Request frame for which a reply from an internal host controller is expected according to the customer's VLAN requirements, an ICMP Echo Reply been received at the expected test station ports.

	<p>2. For no transmitted ICMP Echo Request frame for which no reply from an internal host controller is expected according to the customer's VLAN requirements, an ICMP Echo Reply been received at the expected test station ports.</p> <p>2. Every ICMP Echo Reply frame received at the test station is untagged, single-tagged or double-tagged, respectively, according to the customer's VLAN requirements.</p> <p>2. Every single-tagged or double-tagged ICMP Echo Reply frame carries the correct inner and/or outer TPID and the correct VIDs according to the customer's VLAN requirements.</p>
Reference	802.1Q-2018
Notes	n/a

5.3.1.1.14 SWITCH_VLAN_X014: VLAN_irregular_double-tagged_inner_first_outer_TPID_0x9100_internal_ICMP

Synopsys	Verify that irregularly double-tagged frames with outer TPID 0x8100 and inner TPID 0x9100 are not forwarded to internal ports using unicast ICMP Echo Request messages.
Prerequisites	The DUT is capable of responding to ICMP Echo Request messages.
Test setup	Standard test setup for switching
Test Input Parameters	VLAN configuration
Test Procedure	<ol style="list-style-type: none"> 1. From the test station, send double-tagged unicast ICMP Echo Request frames to every DUT port. For the destination MAC and IP addresses of the frames, the test station shall iterate through the addresses of all internal microcontrollers of the ECU. The inner TPID shall be 0x9100. The outer TPID shall be 0x8100. The VID of the inner and outer tag shall be the same. The test station shall iterate through every VID for every combination of ingress and egress port, including VID 0 and VID 4095. 2. On every test station port, check if ICMP Echo Reply frames are received as expected according to the customer's VLAN requirements.
Pass Criteria	<p>2. For every transmitted ICMP Echo Request frame for which a reply from an internal host controller is expected according to the customer's VLAN requirements, an ICMP Echo Reply been received at the expected test station ports.</p> <p>2. For no transmitted ICMP Echo Request frame for which no reply from an internal host controller is expected according to the customer's VLAN</p>

	<p>requirements, an ICMP Echo Reply been received at the expected test station ports.</p> <p>2. Every ICMP Echo Reply frame received at the test station is untagged, single-tagged or double-tagged, respectively, according to the customer's VLAN requirements.</p> <p>2. Every single-tagged or double-tagged ICMP Echo Reply frame carries the correct inner and/or outer TPID and the correct VID according to the customer's VLAN requirements.</p>
Reference	802.1Q-2018
Notes	n/a

5.3.1.1.15 SWITCH_VLAN_X015: VLAN_untagged_internal_ARP

Synopsis	Check if untagged frames are dropped or forwarded to internal ports according to the customer's VLAN requirements by using ARP Request messages.
Prerequisites	The DUT is capable of responding to ARP Request messages.
Test setup	Standard test setup for switching
Test Input Parameters	VLAN configuration
Test Procedure	<ol style="list-style-type: none"> From the test station, send untagged broadcast ARP Request frames to every DUT port. For the IP addresses of the frames, the test station shall iterate through the addresses of all internal microcontrollers of the ECU. On every test station port, check if ARP Response frames are received as expected according to the customer's VLAN requirements.
Pass Criteria	<p>2. For every transmitted ARP Request frame for which a reply from an internal host controller is expected according to the customer's VLAN requirements, an ARP Response has been received at the expected test station ports.</p> <p>2. For no transmitted ARP Request frame for which no reply from an internal host controller is expected according to the customer's VLAN requirements, an ARP Response been received at the expected test station ports.</p> <p>2. Every ARP Response frame received at the test station is untagged, single-tagged or double-tagged, respectively, according to the customer's VLAN requirements.</p> <p>2. Every single-tagged or double-tagged ICMP Echo Reply frame carries the correct inner and/or outer TPID and the correct VID according to the customer's VLAN requirements.</p>

Reference	802.1Q-2018
Notes	n/a

5.3.1.1.16 SWITCH_VLAN_X016: VLAN_single-tagged_internal_ARP

Synopsis	Check if single-tagged frames are dropped or forwarded to internal ports according to the customer's VLAN requirements by using ARP Request messages.
Prerequisites	The DUT is capable of responding to ARP Request messages.
Test setup	Standard test setup for switching
Test Input Parameters	VLAN configuration
Test Procedure	<ol style="list-style-type: none"> 1. From the test station, send single-tagged broadcast ARP Request frames to every DUT port. For the IP addresses of the frames, the test station shall iterate through the addresses of all internal microcontrollers of the ECU. 2. On every test station port, check if ARP Response frames are received as expected according to the customer's VLAN requirements.
Pass Criteria	<p>2. For every transmitted ARP Request frame for which a reply from an internal host controller is expected according to the customer's VLAN requirements, an ARP Response has been received at the expected test station ports.</p> <p>2. For no transmitted ARP Request frame for which no reply from an internal host controller is expected according to the customer's VLAN requirements, an ARP Response been received at the expected test station ports.</p> <p>2. Every ARP Response frame received at the test station is untagged, single-tagged or double-tagged, respectively, according to the customer's VLAN requirements.</p> <p>2. Every single-tagged or double-tagged ICMP Echo Reply frame carries the correct inner and/or outer TPID and the correct VIDs according to the customer's VLAN requirements.</p>
Reference	802.1Q-2018
Notes	n/a

5.3.1.1.17 SWITCH_VLAN_X017: VLAN_regular_double-tagged_outer_TPID_0x88a8_internal_ARP

Synopsis	Check if regularly double-tagged frames with outer TPID 0x88a8 are dropped or forwarded to internal ports according to the customer's VLAN requirements by using ARP Request messages.
----------	--

Prerequisites	The DUT is capable of responding to ARP Request messages.
Test setup	Standard test setup for switching
Test Input Parameters	VLAN configuration
Test Procedure	<ol style="list-style-type: none"> 1. From the test station, send double-tagged broadcast ARP Request frames to every DUT port. For the IP addresses of the frames, the test station shall iterate through the addresses of all internal microcontrollers of the ECU. The inner TPID shall be 0x8100. The outer TPID shall be 0x88a8. The VID of the inner and outer tag shall be the same. The test station shall iterate through every VID for every combination of ingress and egress port, including VID 0 and VID 4095. 2. On every test station port, check if ARP Response frames are received as expected according to the customer's VLAN requirements.
Pass Criteria	<p>2. For every transmitted ARP Request frame for which a reply from an internal host controller is expected according to the customer's VLAN requirements, an ARP Response has been received at the expected test station ports.</p> <p>2. For no transmitted ARP Request frame for which no reply from an internal host controller is expected according to the customer's VLAN requirements, an ARP Response been received at the expected test station ports.</p> <p>2. Every ARP Response frame received at the test station is untagged, single-tagged or double-tagged, respectively, according to the customer's VLAN requirements.</p> <p>2. Every single-tagged or double-tagged ICMP Echo Reply frame carries the correct inner and/or outer TPID and the correct VIDs according to the customer's VLAN requirements.</p>
Reference	802.1Q-2018
Notes	n/a

5.3.1.1.18 SWITCH_VLAN_X018: VLAN_regular_double-tagged_outer_TPID_0x9100_internal_ARP

Synopsys	Check if regularly double-tagged frames with outer TPID 0x9100 are dropped or forwarded to internal ports according to the customer's VLAN requirements by using ARP Request messages.
Prerequisites	The DUT is capable of responding to ARP Request messages.
Test setup	Standard test setup for switching

Test Input Parameters	VLAN configuration
Test Procedure	<ol style="list-style-type: none"> 1. From the test station, send double-tagged broadcast ARP Request frames to every DUT port. For the IP addresses of the frames, the test station shall iterate through the addresses of all internal microcontrollers of the ECU. The inner TPID shall be 0x8100. The outer TPID shall be 0x9100. The VID of the inner and outer tag shall be the same. The test station shall iterate through every VID for every combination of ingress and egress port, including VID 0 and VID 4095. 2. On every test station port, check if ARP Response frames are received as expected according to the customer's VLAN requirements.
Pass Criteria	<ol style="list-style-type: none"> 2. For every transmitted ARP Request frame for which a reply from an internal host controller is expected according to the customer's VLAN requirements, an ARP Response has been received at the expected test station ports. 2. For no transmitted ARP Request frame for which no reply from an internal host controller is expected according to the customer's VLAN requirements, an ARP Response been received at the expected test station ports. 2. Every ARP Response frame received at the test station is untagged, single-tagged or double-tagged, respectively, according to the customer's VLAN requirements. 2. Every single-tagged or double-tagged ICMP Echo Reply frame carries the correct inner and/or outer TPID and the correct VIDs according to the customer's VLAN requirements.
Reference	802.1Q-2018
Notes	n/a

5.3.1.1.19 SWITCH_VLAN_X019: VLAN_irregular_double-tagged_double_inner_internal_ARP

Synopsis	Verify that irregularly double-tagged frames with two TPIDs 0x8100 are not forwarded to internal ports by using ARP Request messages.
Prerequisites	The DUT is capable of responding to ARP Request messages.
Test setup	Standard test setup for switching
Test Input Parameters	VLAN configuration
Test Procedure	<ol style="list-style-type: none"> 1. From the test station, send double-tagged broadcast ARP Request frames to every DUT port. For the IP addresses of the frames, the test station shall iterate through the addresses of all internal microcontrollers of the ECU.

	<p>The inner TPID shall be 0x8100. The outer TPID shall be 0x8100. The VID of the inner and outer tag shall be the same. The test station shall iterate through every VID for every combination of ingress and egress port, including VID 0 and VID 4095.</p> <p>2. On every test station port, check if ARP Response frames are received as expected according to the customer's VLAN requirements.</p>
Pass Criteria	<p>2. For every transmitted ARP Request frame for which a reply from an internal host controller is expected according to the customer's VLAN requirements, an ARP Response has been received at the expected test station ports.</p> <p>2. For no transmitted ARP Request frame for which no reply from an internal host controller is expected according to the customer's VLAN requirements, an ARP Response been received at the expected test station ports.</p> <p>2. Every ARP Response frame received at the test station is untagged, single-tagged or double-tagged, respectively, according to the customer's VLAN requirements.</p> <p>2. Every single-tagged or double-tagged ICMP Echo Reply frame carries the correct inner and/or outer TPID and the correct VIDs according to the customer's VLAN requirements.</p>
Reference	802.1Q-2018
Notes	n/a

5.3.1.1.20 SWITCH_VLAN_X020: VLAN_irregular_double-tagged_inner_first_outer_TPID_0x88a8_internal_ARP

Synopsis	Verify that irregularly double-tagged frames with outer TPID 0x8100 and inner TPID 0x88a8 are not forwarded to internal ports by using ARP Request messages.
Prerequisites	The DUT is capable of responding to ARP Request messages.
Test setup	Standard test setup for switching
Test Input Parameters	VLAN configuration
Test Procedure	<p>1. From the test station, send double-tagged broadcast ARP Request frames to every DUT port. For the IP addresses of the frames, the test station shall iterate through the addresses of all internal microcontrollers of the ECU. The inner TPID shall be 0x88a8. The outer TPID shall be 0x8100. The VID of the inner and outer tag shall be the same. The test station shall iterate through every VID for every combination of ingress and egress port, including VID 0 and VID 4095.</p>

	<p>2. On every test station port, check if ARP Response frames are received as expected according to the customer's VLAN requirements.</p>
Pass Criteria	<p>2. For every transmitted ARP Request frame for which a reply from an internal host controller is expected according to the customer's VLAN requirements, an ARP Response has been received at the expected test station ports.</p> <p>2. For no transmitted ARP Request frame for which no reply from an internal host controller is expected according to the customer's VLAN requirements, an ARP Response been received at the expected test station ports.</p> <p>2. Every ARP Response frame received at the test station is untagged, single-tagged or double-tagged, respectively, according to the customer's VLAN requirements.</p> <p>2. Every single-tagged or double-tagged ICMP Echo Reply frame carries the correct inner and/or outer TPID and the correct VID's according to the customer's VLAN requirements.</p>
Reference	802.1Q-2018
Notes	n/a

5.3.1.1.21 SWITCH_VLAN_X021: VLAN_irregular_double-tagged_inner_first_outer_TPID_0x9100_internal_ARP

Synopsis	Verify that irregularly double-tagged frames with outer TPID 0x8100 and inner TPID 0x9100 are not forwarded to internal ports by using ARP Request messages.
Prerequisites	The DUT is capable of responding to ARP Request messages.
Test setup	Standard test setup for switching
Test Input Parameters	VLAN configuration
Test Procedure	<p>1. From the test station, send double-tagged broadcast ARP Request frames to every DUT port. For the IP addresses of the frames, the test station shall iterate through the addresses of all internal microcontrollers of the ECU. The inner TPID shall be 0x9100. The outer TPID shall be 0x8100. The VID of the inner and outer tag shall be the same. The test station shall iterate through every VID for every combination of ingress and egress port, including VID 0 and VID 4095.</p> <p>2. On every test station port, check if ARP Response frames are received as expected according to the customer's VLAN requirements.</p>

Pass Criteria	<p>2. For every transmitted ARP Request frame for which a reply from an internal host controller is expected according to the customer's VLAN requirements, an ARP Response has been received at the expected test station ports.</p> <p>2. For no transmitted ARP Request frame for which no reply from an internal host controller is expected according to the customer's VLAN requirements, an ARP Response been received at the expected test station ports.</p> <p>2. Every ARP Response frame received at the test station is untagged, single-tagged or double-tagged, respectively, according to the customer's VLAN requirements.</p> <p>2. Every single-tagged or double-tagged ICMP Echo Reply frame carries the correct inner and/or outer TPID and the correct VIDs according to the customer's VLAN requirements.</p>
Reference	802.1Q-2018
Notes	n/a

5.4 General

5.4.1.1.1 SWITCH_GEN_001: Operate_as_Store_and_Forward_Switch

Synopsis	Check if the switch operates as a Store and Forward Switch
Prerequisites	n/a
Test setup	Standard test setup for switching
Test Input Parameters	VLAN configuration
Test Procedure	<ol style="list-style-type: none"> 3. From the test station, send valid frames to any DUT port such that they are expected to be forwarded to at least one other port. 4. Check if the frames are forwarded to any other port. 5. From the test station, send the same frames as in step 1 to the same DUT port, but with an invalid FCS. 6. Check if the frames are forwarded to any port.
Pass Criteria	<ol style="list-style-type: none"> 2. The test station receives the frames from any other port. 3. The test station does not receive any of the frames sent in step 3 from any port.
Reference	IEEE 802.1Q-2018
Notes	n/a

5.4.1.1.2 SWITCH_GEN_002: Non-blocking_architecture

Synopsys	Check if the switch is implemented with a non-blocking architecture
Prerequisites	On every port, at least one source MAC address has been learned (dynamically or statically).
Test setup	Standard test setup for switching
Test Input Parameters	VLAN configuration
Test Procedure	<ol style="list-style-type: none"> 1. From the test station, continuously send valid unicast frames to every DUT port at 100% line-rate with destination MAC addresses that are learned on a different port. Every DUT port shall be involved exactly one time as ingress port and destination port. 2. At the test station, measure the bit rate of received traffic on every DUT port.
Pass Criteria	2. The bit rate of the forwarded frames is measured to be at least 90% of the port's line rate.
Reference	n/a
Notes	Notes Various effects can cause the egress traffic to be of lower bit rate compared to the ingress traffic, e.g. removal of the VLAN tag at egress, ingress rate limitation, traffic shaping at egress. The tester shall chose traffic that is not prone to any of such predictable limitations.

5.4.1.1.3 SWITCH_GEN_003: Startup_time

Synopsys	Checks if the time from powering to the first forwarded frame is within the acceptable range.
Prerequisites	n/a
Test setup	Switching test setup for triggered time measurements
Test Input Parameters	<ul style="list-style-type: none"> • VLAN configuration • Required startup time
Test Procedure	<ol style="list-style-type: none"> 1. Power off DUT. 2. From the test station, start sending broadcast frames with a frame size of 64 bytes to every DUT. The Inter Packet Gap (IPG) shall not be larger than 500µs. 3. Power on DUT.

	4. Measure the time between power on and the first frame that is received from any port.
Pass Criteria	4. The measured time between power on and the first received frame is below or equal to the required startup time.
Reference	n/a
Notes	The maximum IPG defined in step 2 is dimensioned such that the resolution of the measurement is 1 ms or better, with additional consideration of a generous margin.

5.4.1.1.4 SWITCH_GEN_004: Ingress_Port_Mirroring

Synopsys	Check if switch supports ingress port mirroring as required.
Prerequisites	DUT is required to support ingress port mirroring on at least one external port.
Test setup	Standard test setup for switching
Test Input Parameters	Required ingress port mirroring configuration, including: <ul style="list-style-type: none"> • The subset of external DUT ports on which ingress port mirroring shall be supported • The mirror port(s) for ingress mirroring
Test Procedure	<ol style="list-style-type: none"> 1. From the test station send valid unicast traffic to a port which is required to mirror incoming frames. The frames shall be addressed such that they are expected to be forwarded to another port different than the mirror port. 2. Observe if traffic sent in step 1 is received from the expected destination port. 3. Observe if traffic sent in step 1 is received from the mirror port. 4. Repeat the test steps 1-3 for every port that is required to mirror incoming frames
Pass Criteria	<ol style="list-style-type: none"> 2. The test station receives all frames from the expected destination port. 3. The test station receives all frames from the mirror port. Reference None
Reference	n/a
Notes	n/a

5.4.1.1.5 SWITCH_GEN_005: Egress_Port_Mirroring

Synopsys	Check if switch supports egress port mirroring as required.
Prerequisites	DUT is required to support egress port mirroring on at least one external ports.

	On every port that is required to mirror outgoing frames, at least one source MAC address has been learned (dynamically or statically).
Test setup	Standard test setup for switching
Test Input Parameters	<ul style="list-style-type: none"> • VLAN configuration • Required egress port mirroring configuration, including: <ul style="list-style-type: none"> ○ The subset of external DUT ports on which egress port mirroring shall be supported ○ The mirror port(s) for egress mirroring
Test Procedure	<ol style="list-style-type: none"> 1. From the test station send valid unicast traffic that is addressed to a port which is required to mirror outgoing frames; the frames shall be sent to another port. 2. Observe if traffic sent in step 1 is received from the expected destination port. 3. Observe if traffic sent in step 1 is received from the mirror port. 4. Repeat the test steps 1-3 for every port that is required to mirror outgoing frames
Pass Criteria	<ol style="list-style-type: none"> 2. The test station receives all frames from the expected destination port. 3. The test station receives all frames from the mirror port.
Reference	n/a
Notes	n/a

5.4.1.1.6 SWITCH_GEN_006: Port_Disabling

Synopsis	Check if individual ports can be disabled administratively.
Prerequisites	DUT allows administratively disabling at least one external port. Disabling means here that the according DUT port maintains link up, but it shall not forward frames from or to this port and MAC addresses shall not be learned for frames received at this port.
Test setup	Standard test setup for switching
Test Input Parameters	<ul style="list-style-type: none"> • VLAN configuration • Required egress port mirroring configuration, including: <ul style="list-style-type: none"> ○ The subset of external DUT ports on which egress port mirroring shall be supported ○ The mirror port(s) for egress mirroring
Test Procedure	<ol style="list-style-type: none"> 1. From the test station send traffic to a port A addressed to a port B 2. Observe if test station receives any traffic from port B 3. Through any vendor specified means, disable port B 4. Observe if link at port B is still up when the port is disabled

	<ol style="list-style-type: none"> 5. From the test station send broadcast traffic to port A untagged or tagged such that it is expected to be forwarded to port B if it was not disabled 6. Observe if test station receives any traffic from port B 7. From the test station send broadcast traffic to port B untagged or tagged such that it is expected to be forwarded to port A if port B was not disabled, and with a valid source MAC address X that has not been learnt on any DUT port yet. 8. Observe if test station receives any traffic from port A that has been sent to port B in step 8. 9. If flooding of frames with unknown destination MAC addresses is enabled, then from the test station send traffic to port A addressed to an unknown MAC address. 10. If flooding of frames with unknown destination MAC addresses is enabled, observe if test station receives on any port any traffic that has been sent to port A in step 10. 11. Repeat the test steps 1-11 for all ports that can be disabled as port B.
Pass Criteria	<ol style="list-style-type: none"> 2. The test station receives the frames from port B. 4. Link is up on port B. 6. The test station does not receive the traffic sent in step 5 from port B. 8. The test station does not receive the traffic sent in step 7 from port A. 10. The test station receives the traffic sent in step 9 from at least one DUT port. 10. The test station does not receive the traffic sent in step 9 from port B.
Reference	n/a
Notes	n/a

5.4.1.1.7 SWITCH_GEN_007: Maximum_frame_size_untagged

Synopsis	Check if switch forwards untagged frames only if their size is smaller than or equal to the required maximum frame size.
Prerequisites	The DUT accepts untagged traffic on at least one external port.
Test setup	Standard test setup for switching
Test Input Parameters	<ul style="list-style-type: none"> • VLAN configuration • Required maximum frame size for untagged frames
Test Procedure	<ol style="list-style-type: none"> 1. From the test station, send untagged frames to any DUT port accepting untagged frames with a frame size equal to the required maximum frame size for untagged frames. 2. Check if the frames are forwarded to any other port. 3. From the test station, send the same frames as in step 1 to the same DUT ports, with a frame size that is one byte bigger than the required maximum frame size for untagged frames.

	4. Check if the frames are forwarded to any port.
Pass Criteria	2. The test station receives the frames from any other port. 4. The test station does not receive any of the frames sent in step 3 from any port.
Reference	IEEE 802.3-2015
Notes	n/a

5.4.1.1.8 SWITCH_GEN_008: Maximum_frame_size_single_tagged

Synopsis	Check if switch forwards untagged frames only if their size is smaller than or equal to the required maximum frame size.
Prerequisites	The DUT accepts untagged traffic on at least one external port.
Test setup	Standard test setup for switching
Test Input Parameters	<ul style="list-style-type: none"> • VLAN configuration • Required maximum frame size for untagged frames
Test Procedure	<ol style="list-style-type: none"> 5. From the test station, send untagged frames to any DUT port accepting untagged frames with a frame size equal to the required maximum frame size for untagged frames. 6. Check if the frames are forwarded to any other port. 7. From the test station, send the same frames as in step 1 to the same DUT ports, with a frame size that is one byte bigger than the required maximum frame size for untagged frames. 8. Check if the frames are forwarded to any port.
Pass Criteria	2. The test station receives the frames from any other port. 4. The test station does not receive any of the frames sent in step 3 from any port.
Reference	IEEE 802.3-2015
Notes	n/a

5.4.1.1.9 SWITCH_GEN_009: Maximum_frame_size_double_tagged

Synopsis	Check if switch forwards double-tagged frames only if their size is smaller than or equal to the required maximum frame size.
Prerequisites	The DUT accepts double-tagged traffic on at least one external port.
Test setup	Standard test setup for switching

Test Input Parameters	<ul style="list-style-type: none"> • VLAN configuration • Required maximum frame size for double-tagged frames
Test Procedure	<ol style="list-style-type: none"> 1. From the test station, send validly double-tagged frames to any DUT port accepting double-tagged frames with a frame size equal to the required maximum frame size for double-tagged frames. 2. Check if the frames are forwarded to any other port. 3. From the test station, send the same frames as in step 1 to the same DUT ports, with a frame size that is one byte bigger than the required maximum frame size for double-tagged frames. 4. Check if the frames are forwarded to any port.
Pass Criteria	<ol style="list-style-type: none"> 2. The test station receives the frames from any other port. 4. The test station does not receive any of the frames sent in step 3 from any port.
Reference	IEEE 802.3-2015
Notes	n/a

5.4.1.1.10 SWITCH_GEN_010: Limited_queue_size

Synopsis	Check if the DUT's queue sizes are limited as required.
Prerequisites	<p>DUT is required to limit the internal queue size for specific traffic classes on external ports. The required queue size limitation is to be measured in frames. DUT has at least three external ports. At least one not-limited traffic class is higher than the highest limited traffic class.</p>
Test setup	Standard test setup for switching
Test Input Parameters	<ul style="list-style-type: none"> • VLAN configuration • Information about required limited queue sizes, containing: <ul style="list-style-type: none"> ○ Traffic classes that are required to be limited ○ The required queue sizes ○ The ports on which the queues are limited • Mapping of ingress VLAN PCP values to traffic classes
Test Procedure	<ol style="list-style-type: none"> 1. From the test station, send valid traffic at 100% line-rate such that it is expected to be forwarded to the port on which the queue size limitation is examined in this test iteration; the frames shall be tagged such that they are mapped to the highest traffic class without limited queue size. 2. Wait 1 second. 3. From the test station, send valid traffic at 100% line-rate to a port different than in step 1 such that it is also expected to be forwarded to the port on which the queue size limitation is examined in this test iteration; the frames shall be tagged such that they are mapped to a traffic class with limited queue size.

	<ol style="list-style-type: none"> 4. Wait 2 seconds. 5. Stop all traffic from step 3. 6. Wait 1 second. 7. Stop all traffic from step 1. 8. Wait until no more traffic is received from the port on which the queue size limitation is examined in this test iteration. 9. Determine the total number of frames that have been sent in step 3 and successfully forwarded to the destination port on which the queue size limitation is examined in this test iteration. 10. Repeat steps 1-9 for all traffic classes whose queue sizes are required to be limited. 11. Repeat steps 1-10 for all ports on which the queues are limited.
Pass Criteria	9. The number of frames sent in step 3 and received from the destination port is equal to the required queue size for this traffic class.
Reference	n/a
Notes	n/a

5.5 Address Learning

5.5.1.1.1 SWITCH_ADDR_001: Address_Learning_read_ARL_table

Synopsys	Check if switch supports reading the learned ARL table.
Prerequisites	The DUT allows reading the ARL table.
Test setup	Standard test setup for switching
Test Input Parameters	n/a
Test Procedure	<ol style="list-style-type: none"> 1. Through any vendor specified means have the DUT delete its dynamically learned Address Table entries. 2. Wait 10 seconds. 3. From the test station, send at least 2 untagged and at least 2 tagged frames to each of the DUT ports, each frame with a different, valid source MAC address and each of the tagged frames with a different valid VLAN tag according to the VLAN configuration of the corresponding port. 4. Through any vendor specified means, read the learned MAC address table.
Pass Criteria	4. The read table correctly lists the MAC addresses and the corresponding ports as learned in step 3.
Reference	n/a

Notes	The ARL table MAY contain additional addresses that have been learnt from frames that have been generated from applications behind the internal ports.
-------	--

5.5.1.1.2 SWITCH_ADDR_002: Address_Learning_write_ARL_table

Synopsys	Check if switch supports writing to the learned ARL table.
Prerequisites	The DUT allows writing to the ARL table.
Test setup	Standard test setup for switching
Test Input Parameters	n/a
Test Procedure	<ol style="list-style-type: none"> 1. Through any vendor specified means have the DUT delete its dynamically learned Address Table entries 2. Through any vendor specified means, write to the learned MAC address table. The written address table entries should not contain more than the maximum number of supported, dynamically learnt entries. Furthermore, the written MAC address table should contain both unicast and multicast entries. For every DUT port, there should be at least one unicast and one multicast entry addressing to it. At least one multicast entry shall have two ports assigned to it. 3. From the test station, send frames to every DUT port, each frame addressed to one of the MAC addresses written to the MAC address table in step 2, and untagged or tagged such that the frame is expected to be forwarded to the according port. For every written entry, the corresponding MAC address should be used at least once. 4. At every DUT port, check if the frames have been forwarded correctly.
Pass Criteria	4. The test station receives all frames exclusively at the correct destination ports according to the configuration in step 2.
Reference	n/a
Notes	n/a

5.5.1.1.3 SWITCH_ADDR_003: Address_Learning_at_external_ports_with_untagged_frames

Synopsys	Check if switch is capable of MAC address learning using untagged frames with unique source MAC addresses.
Prerequisites	Optionally, a list of specific MAC addresses to be used for testing is provided by the customer (otherwise, a default list is assumed that - combined with statically learned addresses and addresses learned from frames generated by the DUT itself - leads to an occupation of 256 entries in the ARL table).

Test setup	Standard test setup for switching
Test Input Parameters	<ol style="list-style-type: none"> 1. list of statically configured ARL entries, 2. list of addresses that are learned dynamically from frames generated by the DUT 3. list of MAC addresses to be used for testing; this list can be a specific list provided by the customer (if explicitly requested) or a default list as described in the Prerequisites field.
Test Procedure	<ol style="list-style-type: none"> 1. Through any vendor specified means, have the DUT delete its dynamically learned Address Table entries. 2. Capture and monitor traffic on every port. 3. From the test station, send untagged frames to one external DUT port A, each frame with a different, valid source MAC address from the list of MAC addresses to be tested. For all but one MAC address X in that list, a frame shall be sent. 4. From the test station, send untagged frames addressed to every source MAC address used in step 3 to each of the remaining external DUT ports, each frame using MAC address X from step 3 as source MAC address. 5. At every DUT port, check if the frames have been forwarded. 6. From the test station, send tagged frames addressed to every source MAC address used in step 3 to each of the remaining external DUT ports, each frame using MAC address X from step 3 as source MAC address and tagged with a valid VID according to the VLAN configuration for port A. 7. At every DUT port, check if the frames have been forwarded. 8. Repeat test steps 1 to 7 for every external DUT port as port A.
Pass Criteria	<ol style="list-style-type: none"> 5. At port A, all n frames per each other external port are seen as expected according to the VLAN configuration. 5. At the remaining external ports, no frame is seen. 7. At port A, all n frames per each other external port are seen as expected according to the VLAN configuration. 7. At the remaining external ports, no frame is seen.
Reference	IEEE 802.1Q-2018
Notes	<p>This test does not generally assure that 256 addresses can be learned simultaneously without an unresolved hash conflict. The test only verifies that a particular set of 256 addresses (including statically learned addresses) can be learned into the ARL table. As there exist various hash functions that are commonly used in hash-based address tables, it is in general not possible to specify a set of MAC addresses for testing which would universally cover all possible variants; hence, it is out of the scope of this test specification to deeper investigate the hash conflict behavior of an ECU by default.</p> <p>However, if the customer optionally wishes the hash conflict resolution capabilities to be verified like in the TC11 test specification, the customer is requested to provide a list of MAC addresses to be learned.</p>

5.5.1.1.4 SWITCH_ADDR_004: Address_Learning_at_external_ports_with_tagged_frames

Synopsys	Check if switch is capable of MAC address learning using tagged frames with unique source MAC addresses.
Prerequisites	Optionally, a list of specific MAC addresses to be used for testing is provided by the customer (otherwise, a default list is assumed that - combined with statically learned addresses and addresses learned from frames generated by the DUT itself - leads to an occupation of 256 entries in the ARL table).
Test setup	Standard test setup for switching
Test Input Parameters	<ol style="list-style-type: none"> 1. list of statically configured ARL entries, 2. list of addresses that are learned dynamically from frames generated by the DUT 3. list of MAC addresses to be used for testing; this list can be a specific list provided by the customer (if explicitly requested) or a default list as described in the Prerequisites field.
Test Procedure	<ol style="list-style-type: none"> 1. Through any vendor specified means, have the DUT delete its dynamically learned Address Table entries 2. Capture and monitor traffic on every port 3. From the test station, send tagged frames to one external DUT port A, each frame with a different, valid source MAC address from the list of MAC addresses to be tested and tagged with a valid VID according to the VLAN configuration for port A. For all but one MAC address X in that list, a frame shall be sent. 4. From the test station, send untagged frames addressed to every source MAC address used in step 3 to each of the remaining external DUT ports, each frame using MAC address X from step 3 as source MAC address 5. At every DUT port, check if the frames have been forwarded 6. From the test station, send tagged frames addressed to every source MAC address used in step 3 to each of the remaining external DUT ports, each frame using MAC address X from step 3 as source MAC address and tagged with the same VID as in step 3. 7. At every DUT port, check if the frames have been forwarded 8. From the test station, send tagged frames addressed to every source MAC address used in step 3 to each of the remaining external DUT ports, each frame using MAC address X from step 3 as source MAC address and tagged with a valid VID according to the VLAN configuration, but different than the VID used in step 3. 9. At every DUT port, check if the frames have been forwarded 10. Repeat test steps 1 to 7 for every external DUT port as port A
Pass Criteria	<ol style="list-style-type: none"> 5. At port A, all n frames per each other external port are seen as expected according to the VLAN configuration 5. At the remaining external ports, no frame is seen 7. At port A, all n frames per each other external port are seen as expected according to the VLAN configuration

	<p>7. At the remaining external ports, no frame is seen</p> <p>9. At port A, all n frames per each other external port are seen as expected according to the VLAN configuration</p> <p>9. At the remaining external ports, no frame is seen</p>
Reference	IEEE 802.1Q-2018
Notes	<p>This test does not generally assure that 256 addresses can be learned simultaneously without an unresolved hash conflict. The test only verifies that a particular set of 256 addresses (including statically learned addresses) can be learned into the ARL table. As there exist various hash functions that are commonly used in hash-based address tables, it is in general not possible to specify a set of MAC addresses for testing which would universally cover all possible variants; hence, it is out of the scope of this test specification to deeper investigate the hash conflict behavior of an ECU by default.</p> <p>However, if the customer optionally wishes the hash conflict resolution capabilities to be verified like in the TC11 test specification, the customer is requested to provide a list of MAC addresses to be learned.</p>

5.5.1.1.5 SWITCH_ADDR_005: Address_Learning_at_internal_ports

Synopsis	Check if switch is capable of MAC address learning using untagged frames with unique source MAC addresses.
Prerequisites	n/a
Test setup	Standard test setup for switching
Test Input Parameters	MAC addresses of all microcontrollers that are connected to internal DUT ports
Test Procedure	<ol style="list-style-type: none"> 1. Through any vendor specified means, have the DUT delete its dynamically learned Address Table entries. 2. Capture and monitor traffic on every port. 3. From the test station, send frames that will be processed and answered by the DUT to an external DUT port A, addressed to an internal DUT port B and with a valid VLAN tag. 4. Wait for the test station to receive an answer and note the source MAC address of the answer. 5. From the test station, send frames to an external DUT port A, addressed to the internal port's MAC address obtained in step 4. 6. At the test station, check if the frames are forwarded to any external DUT port. 7. At the test station, check if an answer to the frame sent in step 5 is received from port A. 8. Repeat test steps 1 to 7 for every internal DUT port as port B.

Pass Criteria	5. The test station did not receive the frames from any external DUT port 6. The test station received an answer from port A
Reference	IEEE 802.1Q-2018
Notes	n/a

5.5.1.1.6 SWITCH_ADDR_006: Address_Learning_ageing_negative

Synopsis	Verify that dynamically learned entries in the ARL table do not age.
Prerequisites	<ul style="list-style-type: none"> • Ageing of entries in the ARL table is forbidden on at least one external DUT port. • If ageing of entries in the ARL table is not forbidden on all external ports, the required ageing time is not longer than 30 minutes.
Test setup	Standard test setup for switching
Test Input Parameters	<ul style="list-style-type: none"> • VLAN configuration • DUT Ports on which ageing is forbidden • Any ageing times for other DUT ports, if existing
Test Procedure	<ol style="list-style-type: none"> 1. From the test station, send valid unicast frames to any DUT port B, tagged such that they are expected to be forwarded to a DUT port A on which ageing is forbidden and at least one more DUT port C. 2. At every DUT port, check if the frames from step 1 are forwarded. 3. From the test station, send a valid frame to DUT port A on which ageing is forbidden; the frame shall use the same MAC address as source MAC address that has been used as destination MAC address in step 1. 4. Within less than 5 seconds, from the test station, send the same frames as in step 1 again. 5. At every DUT port, check if the frames from step 4 are forwarded. 6. Wait for at least 105% of the ageing time required at other DUT ports or for at least 15 minutes if ageing is not allowed on any DUT port. 7. From the test station, send the same frames as in step 1 again. 8. At every DUT port, check if the frames from step 7 are forwarded. 9. Repeat steps 1-8 for different DUT ports on which ageing is forbidden until all or at least 3 ports are tested.
Pass Criteria	<ol style="list-style-type: none"> 2. The test station receives the frames from the DUT port A. 2. The test station receives the frames from the DUT port C. 5. The test station receives the frames from the DUT port A. 5. The test station does not receive the frames from any other DUT port. 8. The test station receives the frames from the DUT port A. 8. The test station does not receive the frames from any other DUT port.

Reference	IEEE 802.1Q-2018
Notes	<p>The default ageing time according to IEEE 802.1Q-2018 is 300 seconds. Under the assumption that a switch semiconductor on which no ageing settings have been changed since production will be configured with this default value, 15 minutes can be considered a sufficiently large duration to maintain test reliability while also assuring temporal feasibility of the test.</p> <p>In case that the DUT is required to age entries after an ageing time of significantly more than 30 minutes at particular ports, the overall test duration might exceed typical, justifiable test duration times. The tester, however, may execute the test also for longer ageing times and the test result may also be reported in the test report, but testing long ageing times is not mandatory according to this test specification.</p> <p>In case that the DUT port contains more than 3 DUT ports on which ageing is prohibited, the overall test duration might exceed typical, justifiable test duration times if each of these DUT ports is tested. Therefore, this specification limits the maximum number of iterations to only 3 sample ports. The tester, however, may execute the test also for more than 3 ports and the test result may also be reported in the test report, but testing bigger numbers of ports is not mandatory according to this test specification.</p> <p>With these limitations, the worst case test duration of all mandatory test steps can be held below 120 minutes.</p>

5.5.1.1.7 SWITCH_ADDR_007: Address_Learning_ageing_positive

Synopsis	Verify that dynamically learned entries in the ARL table age.
Prerequisites	<ul style="list-style-type: none"> • Ageing of entries in the ARL table is required on at least one external DUT port. • The required ageing time is not longer than 30 minutes.
Test setup	Standard test setup for switching
Test Input Parameters	<ul style="list-style-type: none"> • VLAN configuration • DUT Ports on which ageing is required • All ageing times for all DUT ports
Test Procedure	<ol style="list-style-type: none"> 1. From the test station, send valid unicast frames to any DUT port B, tagged such that they are expected to be forwarded to a DUT port A on which ageing is forbidden and at least one more DUT port C. 2. At every DUT port, check if the frames from step 1 are forwarded. 3. From the test station, send a valid frame to DUT port A on which ageing is forbidden; the frame shall use the same MAC address as source MAC address that has been used as destination MAC address in step 1. 4. Wait for 90-95% of port A's ageing time.

	<ol style="list-style-type: none"> 5. From the test station, send the same frames as in step 1 again. 6. At every DUT port, check if the frames from step 5 are forwarded. 7. Wait for 105-110% of port A's ageing time. 8. From the test station, send the same frames as in step 1 again. 9. At every DUT port, check if the frames from step 8 are forwarded. 10. Repeat steps 1-9 for different DUT ports on which ageing is required until all or at least 2 ports are tested.
Pass Criteria	<ol style="list-style-type: none"> 2. The test station receives the frames from the DUT port A. 2. The test station receives the frames from the DUT port C. 6. The test station receives the frames from the DUT port A. 6. The test station does not receive the frames from any other DUT port. 9. The test station receives the frames from the DUT port A. 9. The test station receives the frames from the DUT port C.
Reference	IEEE 802.1Q-2018
Notes	<p>In case that the DUT is required to age entries after an ageing time of significantly more than 30 minutes, the overall test duration might exceed typical, justifiable test duration times. The tester, however, may execute the test also for longer ageing times and the test result may also be reported in the test report, but testing long ageing times is not mandatory according to this test specification.</p> <p>In case that the DUT port contains more than 2 DUT ports on which ageing is required, the overall test duration might exceed typical, justifiable test duration times if each of these DUT ports is tested. Therefore, this specification limits the maximum number of iterations to only 2 sample ports. The tester, however, may execute the test also for more than 2 ports and the test result may also be reported in the test report, but testing bigger numbers of ports is not mandatory according to this test specification.</p> <p>With these limitations, the worst case test duration of all mandatory test steps can be held below 150 minutes.</p>

5.5.1.1.8 SWITCH_ADDR_008: Address_Learning_disable_learning_on_specific_port

Synopsis	Check if address learning is disabled on specific ports as required.
Prerequisites	Disabling of address learning is required on at least one DUT port.
Test setup	Standard test setup for switching

Test Input Parameters	<ul style="list-style-type: none"> • VLAN configuration • Ports on which address learning is required to be disabled
Test Procedure	<ol style="list-style-type: none"> 1. From the test station, send valid unicast frames to one DUT port B, tagged such that they are expected to be forwarded to a DUT port A on which address learning is required to be disabled and to at least one more DUT port C. 2. At every DUT port, check if the frames from step 1 are forwarded. 3. From the test station, send a valid frame to DUT port A; the frame shall use the same MAC address as source MAC address that has been used as destination MAC address in step 1. 4. From the test station, send the same frames as in step 1 again. 5. At every DUT port, check if the frames from step 4 are forwarded. 6. Repeat steps 1-5 for every DUT port on which address learning is required to be disabled as port A.
Pass Criteria	<ol style="list-style-type: none"> 2. The test station receives the frames from the DUT port A. 2. The test station receives the frames from the DUT port C. 5. The test station receives the frames from the DUT port A. 5. The test station receives the frames from the DUT port C.
Reference	IEEE 802.1Q-2018
Notes	n/a

5.5.1.1.9 SWITCH_ADDR_009: Address_Learning_flood_frames_with_unknown_destination_address

Synopsys	Check if the switch floods frames with unknown destination addresses.
Prerequisites	DUT is required to flood frames with unknown destination MAC addresses.
Test setup	Standard test setup for switching
Test Input Parameters	<ul style="list-style-type: none"> • VLAN configuration • At least one unicast MAC address that is not (statically or dynamically) learned • At least one multicast MAC address that is not (statically or dynamically) learned
Test Procedure	<ol style="list-style-type: none"> 1. From the test station, send valid broadcast frames to any external DUT port, tagged such that they are expected to be forwarded to at least two more DUT ports. 2. At every DUT port, check if the frames from step 1 are forwarded. 3. From the test station, send the same frames as in step 1 again, but with an unknown unicast MAC address. 4. At every DUT port, check if the frames from step 3 are forwarded.

	<ol style="list-style-type: none"> 5. From the test station, send the same frames as in step 1 again, but with an unknown multicast MAC address. 6. At every DUT port, check if the frames from step 3 are forwarded.
Pass Criteria	<ol style="list-style-type: none"> 2. The test station receives the frames from at least two DUT ports. 4. The test station receives the frames from at least two DUT ports. 6. The test station receives the frames from at least two DUT ports.
Reference	IEEE 802.1Q-2018
Notes	n/a

5.5.1.1.10 SWITCH_ADDR_010: Address_Learning_drop_frames_with_unknown_destination_address

Synopsys	Check if the switch drops frames with unknown destination addresses.
Prerequisites	DUT is required to drop frames with unknown destination MAC addresses.
Test setup	Standard test setup for switching
Test Input Parameters	<ul style="list-style-type: none"> • VLAN configuration • At least one unicast MAC address that is not (statically or dynamically) learned • At least one multicast MAC address that is not (statically or dynamically) learned
Test Procedure	<ol style="list-style-type: none"> 1. From the test station, send valid broadcast frames to any external DUT port, tagged such that they are expected to be forwarded to at least two DUT ports. 2. At every DUT port, check if the frames from step 1 are forwarded. 3. From the test station, send the same frames as in step 1 again, but with an unknown unicast MAC address. 4. At every DUT port, check if the frames from step 3 are forwarded. 5. From the test station, send the same frames as in step 1 again, but with an unknown multicast MAC address. 6. At every DUT port, check if the frames from step 3 are forwarded.
Pass Criteria	<ol style="list-style-type: none"> 2. The test station receives the frames from at least two DUT ports. 4. The test station does not receive the frames from any DUT ports. 6. The test station does not receive the frames from any DUT ports.
Reference	IEEE 802.1Q-2018
Notes	n/a

5.5.1.1.11 SWITCH_ADDR_011:

Address_Learning_forward_frames_with_unknown_destination_address_to_specific_external_port

Synopsys	Check if the switch forwards frames with unknown destination addresses to a specific external port.
Prerequisites	DUT is required to forward frames with unknown destination MAC addresses to a specific external port.
Test setup	Standard test setup for switching
Test Input Parameters	<ul style="list-style-type: none"> • VLAN configuration • At least one unicast MAC address that is not (statically or dynamically) learned • At least one multicast MAC address that is not (statically or dynamically) learned
Test Procedure	<ol style="list-style-type: none"> 1. From the test station, send valid broadcast frames to any external DUT port A, tagged such that they are expected to be forwarded to at least two more DUT ports. Port A shall not be the port to which frames with unknown destination addresses are required to be forwarded. 2. At every DUT port, check if the frames from step 1 are forwarded. 3. From the test station, send the same frames as in step 1 again, but with an unknown unicast MAC address. 4. At every DUT port, check if the frames from step 3 are forwarded. 5. From the test station, send the same frames as in step 1 again, but with an unknown multicast MAC address. 6. At every DUT port, check if the frames from step 3 are forwarded.
Pass Criteria	<ol style="list-style-type: none"> 2. The test station receives the frames from at least two DUT ports. 4. The test station receives the frames from the DUT port to which frames with unknown destination addresses are required to be forwarded. 4. The test station does not receive the frames from any other DUT ports. 6. The test station receives the frames from the DUT port to which frames with unknown destination addresses are required to be forwarded. 6. The test station does not receive the frames from any other DUT ports.
Reference	IEEE 802.1Q-2018
Notes	n/a

5.5.1.1.12 SWITCH_ADDR_012:

Address_Learning_forward_frames_with_unknown_destination_address_to_specific_internal_port

Synopsys	Check if the switch forwards frames with unknown destination addresses to a specific internal port.
----------	---

Prerequisites	<ul style="list-style-type: none"> • DUT is required to forward frames with unknown destination MAC addresses to a specific internal port. • DUT supports reading the TX counters for the internal port to which frames with unknown destination addresses are required to be forwarded.
Test setup	Standard test setup for switching
Test Input Parameters	<ul style="list-style-type: none"> • VLAN configuration • At least one unicast MAC address that is not (statically or dynamically) learned • At least one multicast MAC address that is not (statically or dynamically) learned
Test Procedure	<ol style="list-style-type: none"> 1. From the test station, send valid broadcast frames to any external DUT port A, tagged such that they are expected to be forwarded to at least two more DUT ports. 2. At every DUT port, check if the frames from step 1 are forwarded. 3. Through any vendor defined method, read out the TX packet counters for the internal DUT port to which frames with unknown destination addresses are required to be forwarded. 4. From the test station, send the same frames as in step 1 again, but with an unknown unicast MAC address. 5. At every DUT port, check if the frames from step 3 are forwarded. 6. Through any vendor defined method, read out the TX packet counters for the internal DUT port to which frames with unknown destination addresses are required to be forwarded. 7. From the test station, send the same frames as in step 1 again, but with an unknown multicast MAC address. 8. At every DUT port, check if the frames from step 3 are forwarded. 9. Through any vendor defined method, read out the TX packet counters for the internal DUT port to which frames with unknown destination addresses are required to be forwarded.
Pass Criteria	<ol style="list-style-type: none"> 2. The test station receives the frames from at least two DUT ports. 5. The test station does not receive the frames from any external DUT port. 6. The TX packet counter value has accordingly incremented compared to the value read out in step 3. 8. The test station does not receive the frames from any other DUT ports. 9. The TX packet counter value has accordingly incremented compared to the value read out in step 3.
Reference	IEEE 802.1Q-2018
Notes	If the DUT contains more than one internal port, then it is possible that the microcontrollers behind these internal ports are continuously exchanging frames during the test. In that case, the tester is encouraged to send significantly more frames than the internal ports, in

	order to validate the plausibility of the frame counters. A precise test result, however, will not be possible with such an alternative approach; therefore, the test report shall not contain a definitive pass or fail in that case and instead shall only mention the observed behavior in an informational statement.
--	---

5.5.1.1.13 SWITCH_ADDR_013: Address_Learning_ARL_table_overflow_info

Synopsys	Check if the switch provides a status information and the last dropped MAC address when an ARL table overflow occurs.
Prerequisites	<ul style="list-style-type: none"> • Status information for ARL table overflow is required. • Reporting the last dropped MAC address after an ARL table overflow is required.
Test setup	Standard test setup for switching
Test Input Parameters	<ul style="list-style-type: none"> • VLAN configuration • Number of dynamically and statically learned addresses N • ARL table size S
Test Procedure	<ol style="list-style-type: none"> 1. From the test station, send (S-N) valid frames to the DUT, each frame to any single port and with a different, valid source MAC address. 2. Through any vendor specified method, check if the DUT reports an overflow in the address table. 3. From the test station, send 1 more valid frames to the DUT with another different, valid source MAC address. The source MAC address of this frame shall be noted for later use. 4. Through any vendor specified method, check if the DUT reports an overflow in the address table. 5. Through any vendor specified method, read out the last dropped MAC address.
Pass Criteria	<ol style="list-style-type: none"> 2. The DUT does not report an overflow 4. The DUT reports an overflow 5. The reported MAC address is the source MAC address as used in step 3
Reference	n/a
Notes	n/a

5.5.1.1.14 SWITCH_ADDR_014: Address_Learning_statically_learned_addresses

Synopsys	Check if the switch is configured with statically learned addresses as required.
Prerequisites	At least one statically learned address is required.

Test setup	Standard test setup for switching
Test Input Parameters	VLAN configuration All statically learned unicast and multicast ARL table entries, including the according destination ports.
Test Procedure	<ol style="list-style-type: none"> 1. From the test station, send frames to any DUT port A with a source MAC address that is required to be statically learned. Port A shall not be a destination port for this MAC address. 2. From the test station, send frames to another DUT port B with the source MAC addresses from step 1 as the destination MAC address. Port B shall not be a destination port for this MAC address. 3. At every DUT port, check if the frames have been forwarded. 4. Repeat test steps 1-3 for every required statically learned MAC address.
Pass Criteria	<ol style="list-style-type: none"> 3. The test station receives the frames from every DUT port that is required to be a destination port for the according MAC address. 4. The test station receives the frames from no other DUT port.
Reference	IEEE 802.1Q-2018
Notes	n/a

5.5.1.1.15 SWITCH_ADDR_015: Address_Learning_one_shot_mode_enabled

Synopsis	Verify that the switch learns MAC addresses in one-shot mode, i.e. an existing MAC address in the ARL table is never dynamically re-learned on a different port unless it is aged out.
Prerequisites	One-shot address learning is required.
Test setup	Standard test setup for switching
Test Input Parameters	VLAN configuration
Test Procedure	<ol style="list-style-type: none"> 1. From the test station, send a valid frame to one DUT port A. 2. From the test station, send a valid frame to another DUT port B with the same source MAC address as in step 1. 3. From the test station, send frames to a third DUT port C, using the source MAC address from step 1 and 2 as the destination MAC address. 4. At DUT ports A and B, check if the frames have been forwarded.
Pass Criteria	<ol style="list-style-type: none"> 4. The test station receives the frames from port A 4. The test station does not receive the frames from port B

Reference	n/a
Notes	n/a

5.5.1.1.16 SWITCH_ADDR_016: Address_Learning_one_shot_mode_disabled

Synopsis	Verify that the switch does not learn MAC addresses in one-shot mode, i.e. an existing MAC address in the ARL table can be dynamically re-learned on a different port.
Prerequisites	One-shot address learning is not allowed.
Test setup	Standard test setup for switching
Test Input Parameters	VLAN configuration
Test Procedure	<ol style="list-style-type: none"> 1. From the test station, send a valid frame to one DUT port A. 2. From the test station, send a valid frame to another DUT port B with the same source MAC address as in step 1. 3. From the test station, send frames to a third DUT port C, using the source MAC address from step 1 and 2 as the destination MAC address. 4. At DUT ports A and B, check if the frames have been forwarded.
Pass Criteria	<ol style="list-style-type: none"> 4. The test station does not receive the frames from port A 4. The test station receives the frames from port B
Reference	IEEE 802.1Q-2018
Notes	n/a

5.5.1.1.17 SWITCH_ADDR_017: Address_Learning_limited_number_of_learned_addresses_per_port

Synopsis	Check if the switch has the number of learned addresses limited as required.
Prerequisites	Number of learned addresses is required to be limited on at least one DUT port.
Test setup	Standard test setup for switching
Test Input Parameters	<ul style="list-style-type: none"> • VLAN configuration • Ports on which the number of learned addresses is required to be limited • Maximum number N of addresses that are allowed to be dynamically learned on these ports
Test Procedure	<ol style="list-style-type: none"> 1. From the test station, send N valid frames to any DUT port A, each frame with a different source MAC address.

	<ol style="list-style-type: none"> 2. From the test station, send N valid frames to another DUT port B, each frame using one of the source MAC addresses from step 1 as the destination MAC address, tagged such that they are expected to be forwarded to DUT port A and at least one more DUT port. 3. At every DUT port, check if the frames have been forwarded. 4. From the test station, send 1 valid frame to DUT port A, with a source MAC address different than in step 1. 5. From the test station, send 1 frame to DUT port B, using the source MAC addresses from step 4 as the destination MAC address, tagged such that they are expected to be forwarded to DUT port A and at least one more DUT port. 6. At every DUT port, check if the frame has been forwarded.
Pass Criteria	<ol style="list-style-type: none"> 3. The test station receives the frames from DUT port A. 3. The test station does not receive the frames from any other DUT port. 6. The test station receives the frames from at least two DUT ports.
Reference	n/a
Notes	n/a

5.5.1.1.18 SWITCH_ADDR_018: Shared VLAN Learning

Synopsis	Check if Shared VLAN Learning (SVL) is implemented.
Prerequisites	n/a
Test setup	Standard test setup for switching
Test Input Parameters	VLAN configuration
Test Procedure	<ol style="list-style-type: none"> 1. From the test station, send a valid tagged frame to a DUT port A. 2. From the test station, send tagged frames to another DUT port B, with the source MAC address from step 1 used as the destination MAC address. The VID shall be different than in step 1 and chosen such that the frames are expected to be forwarded to port A and at least one more DUT port. 3. At every DUT port, check if the frames have been forwarded.
Pass Criteria	<ol style="list-style-type: none"> 2. The test station receives the frames from DUT port A. 3. The test station does not receive the frames from any other DUT port.
Reference	IEEE 802.1Q-2018

Notes	n/a
-------	-----

5.5.1.1.19 SWITCH_ADDR_019: No_learning_of_multicast_addresses

Synopsys	Verify that the switch does not dynamically learn multicast MAC addresses.
Prerequisites	DUT floods frames with unknown destination MAC addresses.
Test setup	Standard test setup for switching
Test Input Parameters	<ul style="list-style-type: none"> • VLAN configuration • Multicast addresses
Test Procedure	<ol style="list-style-type: none"> 1. From the test station, send valid frames to one DUT port A with a valid, not yet learned multicast MAC source address 2. From the test station, send valid frames to each of the remaining DUT ports, each frame using the MAC Multicast source address from step 1 as the destination MAC address. The frames shall be untagged or tagged such that they are expected to be forwarded on DUT port A and at least on one more DUT port B. 3. At every DUT port, check if the frames from step 2 are forwarded.
Pass Criteria	3. The test station receives the frames at from DUT ports A and B.
Reference	IEEE 802.1Q-2018
Notes	n/a

5.5.1.1.20 SWITCH_ADDR_020: Block_frames_with_unknown_source_MAC_address

Synopsys	Check if switch blocking frames with unknown source MAC addresses as required.
Prerequisites	DUT is required to block frames with unknown source MAC addresses on at least one external port.
Test setup	Standard test setup for switching
Test Input Parameters	<ul style="list-style-type: none"> • Information on which external DUT ports blocking of frames with unknown source MAC addresses is required • For every external DUT port that is expected to block frames with unknown source MAC addresses, at least one MAC address that is statically learned and one that is not learned.
Test Procedure	<ol style="list-style-type: none"> 1. From the test station, send valid frames to every DUT port that is required to block frames with unknown source MAC addresses. The source MAC address of these frames shall be one that is statically learned address on this port.

	<ol style="list-style-type: none"> 2. Check if the frames are forwarded to any other port. 3. From the test station, send the same frames as in step 1 to the same DUT ports, but with a source MAC address that is not learned on that port. 4. Check if the frames are forwarded to any port.
Pass Criteria	<ol style="list-style-type: none"> 2. The test station receives the frames from any other port. 4. The test station does not receive any of the frames sent in step 3 from any port.
Reference	n/a
Notes	This functionality may be required for specific implementations of 802.1X; however, this test must not be regarded as sufficient for 802.1X compliance verification which would require additional detailed protocol tests.

5.5.1.1.21 SWITCH_ADDR_021: Forward_frames_with_unknown_source_address_to_specific_ports

Synopsis	Check if switch forwards frames with unknown source MAC addresses to specific ports as required.
Prerequisites	DUT is required to forward frames with unknown source MAC addresses to specific ports.
Test setup	Standard test setup for switching
Test Input Parameters	Information on which external DUT ports forwarding of frames with unknown source MAC addresses to specific ports is required, and to which specific ports these frames are required to be forwarded to.
Test Procedure	<ol style="list-style-type: none"> 1. From the test station, send valid frames to every DUT port that is required to forward frames with unknown source MAC addresses to specific ports. The source MAC address of these frames shall be one that is statically learned address on this port. 2. Check if the frames are forwarded to any other port as expected. 3. Through any vendor defined method, read out the TX frames counters for every internal DUT port. 4. From the test station, send the same frames as in step 1 to the same DUT ports, but with a source MAC address that is not learned on that port. 5. Check if the frames are forwarded to any port. 6. Through any vendor defined method, read out the TX frames counters for every internal DUT port.
Pass Criteria	<ol style="list-style-type: none"> 2. The test station receives the frames from any other port as expected. 5. The test station receives the frames on those external ports to which frames with unknown source MAC addresses are required to be forwarded to. 5. The test station does not receive the frames on any other external port.

	6. The read TX frames counters is higher than in step 4.
Reference	n/a
Notes	<p>If the DUT contains more than one internal port, then it is possible that the microcontrollers behind these internal ports are continuously exchanging frames during the test. In that case, the tester is encouraged to send significantly more frames than the internal ports, in order to validate the plausibility of the frame counters. A precise test result, however, will not be possible with such an alternative approach; therefore, the test report shall not contain a definitive pass or fail in that case and instead shall only mention the observed behavior in an informational statement.</p> <p>This functionality may be required for specific implementations of 802.1X; however, this test must not be regarded as sufficient for 802.1X compliance verification which would require additional detailed protocol tests.</p>

5.6 Filtering of incoming frames

5.6.1.1.1 SWITCH_FILT_001: Filtering_drop_untagged

Synopsis	Check if specific frames are dropped as required using untagged frames.
Prerequisites	<p>Dropping of specific frames is required on at least one DUT port.</p> <p>Untagged frames are accepted on at least one DUT port on which dropping of specific frames is required.</p>
Test setup	Standard test setup for switching
Test Input Parameters	<ul style="list-style-type: none"> • VLAN configuration • All required filter definitions on every DUT port for dropping specific frames
Test Procedure	<ol style="list-style-type: none"> 1. From the test station, send valid untagged frames to a DUT port A that accepts untagged frames and on which dropping of specific frames is required. These frames shall be constructed such that no filtering rule will apply. 2. At the test station, check if the frames sent in step 1 are forwarded to any other DUT port. 3. From the test station, send valid untagged frames to DUT port A. These frames shall be constructed such that one filtering rule for dropping specific frames is expected to apply. 4. At the test station, check if the frames sent in step 3 are forwarded to any other DUT port. 5. Repeat steps 3-4 for every filtering rule for dropping specific frames.

Pass Criteria	<p>2. The test station receives the frames sent in step 1.</p> <p>4. The test station does not receive any frame sent in step 3.</p>
Reference	n/a
Notes	<p>Frame filtering that is based on native filtering mechanisms like VLAN handling and address resolution is not subject to this test case.</p> <p>Testability depends on the overall QoS and Policing configuration of the DUT. Certain constellations of combined QoS and Policing mechanisms might cause that the test is not entirely testable according to this specification, but possibly with an alternative test specifically tailored for the respective configuration; however, such an alternative approach would require deeper analysis of multiple configuration aspects and is therefore not within the scope of this test specification.</p>

5.6.1.1.2 SWITCH_FILT_002: Filtering_drop_single-tagged

Synopsys	Check if specific frames are dropped as required using single-tagged frames.
Prerequisites	Dropping of specific frames is required on at least one DUT port.
Test setup	Standard test setup for switching
Test Input Parameters	<ul style="list-style-type: none"> • VLAN configuration • All required filter definitions on every DUT port for dropping specific frames
Test Procedure	<ol style="list-style-type: none"> 1. From the test station, send valid single-tagged frames to a DUT port A that accepts untagged frames and on which dropping of specific frames is required. These frames shall be constructed such that no filtering rule will apply. 2. At the test station, check if the frames sent in step 1 are forwarded to any other DUT port. 3. From the test station, send valid single-tagged frames to DUT port A. These frames shall be constructed such that one filtering rule for dropping specific frames is expected to apply. 4. At the test station, check if the frames sent in step 3 are forwarded to any other DUT port. 5. Repeat steps 3-4 for every filtering rule for dropping specific frames.
Pass Criteria	<p>2. The test station receives the frames sent in step 1.</p> <p>4. The test station does not receive any frame sent in step 3.</p>
Reference	n/a
Notes	Frame filtering that is based on native filtering mechanisms like VLAN handling and address resolution is not subject to this test case.

	<p>Testability depends on the overall QoS and Policing configuration of the DUT. Certain constellations of combined QoS and Policing mechanisms might cause that the test is not entirely testable according to this specification, but possibly with an alternative test specifically tailored for the respective configuration; however, such an alternative approach would require deeper analysis of multiple configuration aspects and is therefore not within the scope of this test specification.</p>
--	---

5.6.1.1.3 SWITCH_FILT_003: Filtering_drop_double-tagged

Synopsis	Check if specific frames are dropped as required using double-tagged frames.
Prerequisites	<p>Dropping of specific frames is required on at least one DUT port.</p> <p>Double-tagged frames are accepted on at least one DUT port on which dropping of specific frames is required.</p>
Test setup	Standard test setup for switching
Test Input Parameters	<ul style="list-style-type: none"> • VLAN configuration • All required filter definitions on every DUT port for dropping specific frames
Test Procedure	<ol style="list-style-type: none"> 1. From the test station, send valid double-tagged frames to a DUT port A that accepts untagged frames and on which dropping of specific frames is required. These frames shall be constructed such that no filtering rule will apply. 2. At the test station, check if the frames sent in step 1 are forwarded to any other DUT port. 3. From the test station, send valid double-tagged frames to DUT port A. These frames shall be constructed such that one filtering rule for dropping specific frames is expected to apply. 4. At the test station, check if the frames sent in step 3 are forwarded to any other DUT port. 5. Repeat steps 3-4 for every filtering rule for dropping specific frames.
Pass Criteria	<ol style="list-style-type: none"> 2. The test station receives the frames sent in step 1. 4. The test station does not receive any frame sent in step 3.
Reference	n/a
Notes	<p>Frame filtering that is based on native filtering mechanisms like VLAN handling and address resolution is not subject to this test case.</p> <p>Testability depends on the overall QoS and Policing configuration of the DUT. Certain constellations of combined QoS and Policing mechanisms might cause that the test is not entirely testable according to this specification, but possibly with an alternative test specifically tailored for the respective configuration; however, such an alternative approach</p>

	would require deeper analysis of multiple configuration aspects and is therefore not within the scope of this test specification.
--	---

5.6.1.1.4 SWITCH_FILT_004: Filtering_forward_to_specific_port_untagged

Synopsys	Check if specific frames are forwarded to a specific port as required using untagged frames.
Prerequisites	Forwarding of specific frames to a specific port is required on at least one DUT port. Untagged frames are accepted on at least one DUT port on which forwarding of specific frames to a specific port is required.
Test setup	Standard test setup for switching
Test Input Parameters	<ul style="list-style-type: none"> • VLAN configuration • All required filtering rules for forwarding of specific frames to a specific port on every DUT port, including: <ul style="list-style-type: none"> ○ Filter definition for which the specific forwarding applies ○ The required destination port
Test Procedure	<ol style="list-style-type: none"> 1. From the test station, send valid untagged frames to a DUT port A that accepts untagged frames and on which filtering rules for specific forwarding is required. These frames shall be constructed such that no filtering rule will apply and that the frames are expected to be forwarded to at least two other DUT ports. 2. At the test station, check if the frames sent in step 1 are forwarded to any other DUT port. 3. From the test station, send valid untagged frames to DUT port A. These frames shall be constructed such that one filtering rule for specific forwarding is expected to apply and that the frames would be expected to be forwarded to at least two other DUT ports if the specific forwarding rule would not exist. 4. At the test station, check if the frames sent in step 3 are forwarded to any other DUT port. 5. Repeat steps 3-4 for every filtering rule for specific forwarding.
Pass Criteria	<ol style="list-style-type: none"> 2. The test station receives the frames sent in step 1 from at least two DUT ports. 4. The test station receives the frames sent in step 3 from the DUT port specified in the specific forwarding rule. 4. The test station does not receive the frames sent in step 3 from any other DUT port.
Reference	n/a

Notes	<p>Frame filtering that is based on native forwarding mechanisms like address resolution is not subject to this test case.</p> <p>Testability depends on the overall QoS and Policing configuration of the DUT. Certain constellations of combined QoS and Policing mechanisms might cause that the test is not entirely testable according to this specification, but possibly with an alternative test specifically tailored for the respective configuration; however, such an alternative approach would require deeper analysis of multiple configuration aspects and is therefore not within the scope of this test specification.</p>
-------	--

5.6.1.1.5 SWITCH_FILT_005: Filtering_forward_to_specific_port_single-tagged

Synopsis	Check if specific frames are forwarded to a specific port as required using single-tagged frames.
Prerequisites	<p>Forwarding of specific frames to a specific port is required on at least one DUT port.</p> <p>Test setup Standard test setup for switching</p>
Test setup	Standard test setup for switching
Test Input Parameters	<ul style="list-style-type: none"> • VLAN configuration • All required filtering rules for forwarding of specific frames to a specific port on every DUT port, including: <ul style="list-style-type: none"> ○ Filter definition for which the specific forwarding applies ○ The required destination port
Test Procedure	<ol style="list-style-type: none"> 1. From the test station, send valid double-tagged frames to a DUT port A on which filtering rules for specific forwarding is required. These frames shall be constructed such that no filtering rule will apply and that the frames are expected to be forwarded to at least two other DUT ports. 2. At the test station, check if the frames sent in step 1 are forwarded to any other DUT port. 3. From the test station, send valid double-tagged frames to DUT port A. These frames shall be constructed such that one filtering rule for specific forwarding is expected to apply and that the frames would be expected to be forwarded to at least two other DUT ports if the specific forwarding rule would not exist. 4. At the test station, check if the frames sent in step 3 are forwarded to any other DUT port. 5. Repeat steps 3-4 for every filtering rule for specific forwarding.
Pass Criteria	<ol style="list-style-type: none"> 2. The test station receives the frames sent in step 1 from at least two DUT ports. 4. The test station receives the frames sent in step 3 from the DUT port specified in the specific forwarding rule.

	4. The test station does not receive the frames sent in step 3 from any other DUT port.
Reference	n/a
Notes	<p>Frame filtering that is based on native forwarding mechanisms like address resolution is not subject to this test case.</p> <p>Testability depends on the overall QoS and Policing configuration of the DUT. Certain constellations of combined QoS and Policing mechanisms might cause that the test is not entirely testable according to this specification, but possibly with an alternative test specifically tailored for the respective configuration; however, such an alternative approach would require deeper analysis of multiple configuration aspects and is therefore not within the scope of this test specification.</p>

5.6.1.1.6 SWITCH_FILT_006: Filtering_forward_to_specific_port_double-tagged

Synopsis	Check if specific frames are forwarded to a specific port as required using double-tagged frames.
Prerequisites	<p>Forwarding of specific frames to a specific port is required on at least one DUT port.</p> <p>Double-tagged frames are accepted on at least one DUT port on which forwarding of specific frames to a specific port is required.</p>
Test setup	Standard test setup for switching
Test Input Parameters	<ul style="list-style-type: none"> • VLAN configuration • All required filtering rules for forwarding of specific frames to a specific port on every DUT port, including: <ul style="list-style-type: none"> ○ Filter definition for which the specific forwarding applies ○ The required destination port
Test Procedure	<ol style="list-style-type: none"> 1. From the test station, send valid double-tagged frames to a DUT port A that accepts double-tagged frames and on which filtering rules for specific forwarding is required. These frames shall be constructed such that no filtering rule will apply and that the frames are expected to be forwarded to at least two other DUT ports. 2. At the test station, check if the frames sent in step 1 are forwarded to any other DUT port. 3. From the test station, send valid double-tagged frames to DUT port A. These frames shall be constructed such that one filtering rule for specific forwarding is expected to apply and that the frames would be expected to be forwarded to at least two other DUT ports if the specific forwarding rule would not exist. 4. At the test station, check if the frames sent in step 3 are forwarded to any other DUT port. 5. Repeat steps 3-4 for every filtering rule for specific forwarding.

Pass Criteria	<p>2. The test station receives the frames sent in step 1 from at least two DUT ports.</p> <p>4. The test station receives the frames sent in step 3 from the DUT port specified in the specific forwarding rule.</p> <p>4. The test station does not receive the frames sent in step 3 from any other DUT port.</p>
Reference	n/a
Notes	<p>Frame filtering that is based on native forwarding mechanisms like address resolution is not subject to this test case.</p> <p>Testability depends on the overall QoS and Policing configuration of the DUT. Certain constellations of combined QoS and Policing mechanisms might cause that the test is not entirely testable according to this specification, but possibly with an alternative test specifically tailored for the respective configuration; however, such an alternative approach would require deeper analysis of multiple configuration aspects and is therefore not within the scope of this test specification.</p>

5.6.1.1.7 SWITCH_FILT_007: Ingress_rate_limitation_untagged

Synopsis	Check if ingress rate limitation is implemented as required using untagged frames.
Prerequisites	<p>Ingress rate limitation for specific frames is required on at least one DUT port.</p> <p>Untagged frames are accepted on at least one DUT port on which ingress rate limitation is required.</p>
Test setup	Standard test setup for switching
Test Input Parameters	<ul style="list-style-type: none"> • VLAN configuration • All required ingress rate limitation rules on every DUT port, including: <ul style="list-style-type: none"> ○ Filter definition for which the limitation applies ○ The maximum allowed ingress rate of the particular limitation
Test Procedure	<ol style="list-style-type: none"> 1. From the test station, send valid untagged frames to a DUT port A that accepts untagged frames and on which ingress rate limitation is required. These frames shall be constructed such that no ingress rate limitation rule is expected to apply. The data rate shall be by at least 10% higher than the maximum allowed ingress rate for that ingress rate limitation rule. 2. At the test station, measure the data rate at one DUT port that forwards these frames. 3. From the test station, send valid untagged frames to a DUT port A that accepts untagged frames and on which ingress rate limitation is required. These frames shall be constructed such that one ingress rate limitation rule

	<p>is expected to apply. The data rate shall be by at least 10% higher than the maximum allowed ingress rate for that ingress rate limitation rule.</p> <ol style="list-style-type: none"> 4. At the test station, measure the data rate of the traffic sent in step 3 at one DUT port that forwards these frames. 5. Repeat steps 3-4 for every ingress rate limitation rule on every DUT port.
Pass Criteria	<ol style="list-style-type: none"> 2. The test station receives traffic with 100% line-rate. 4. The test station receives the traffic sent in step 3 with a data rate according to the required corresponding ingress rate limitation rule.
Reference	802.1Q-2018
Notes	<p>Testability depends on the overall QoS and Policing configuration of the DUT. Certain constellations of combined QoS and Policing mechanisms might cause that the test is not entirely testable according to this specification, but possibly with an alternative test specifically tailored for the respective configuration; however, such an alternative approach would require deeper analysis of multiple configuration aspects and is therefore not within the scope of this test specification.</p>

5.6.1.1.8 SWITCH_FILT_008: Ingress_rate_limitation_single-tagged

Synopsis	Check if ingress rate limitation is implemented as required using single-tagged frames.
Prerequisites	Ingress rate limitation for specific frames is required on at least one DUT port.
Test setup	Standard test setup for switching
Test Input Parameters	<ul style="list-style-type: none"> • VLAN configuration • All required ingress rate limitation rules on every DUT port, including: <ul style="list-style-type: none"> ○ Filter definition for which the limitation applies ○ The maximum allowed ingress rate
Test Procedure	<ol style="list-style-type: none"> 1. From the test station, send valid single-tagged frames to a DUT port A on which ingress rate limitation is required. These frames shall be constructed such that no ingress rate limitation rule is expected to apply. The data rate shall be by at least 10% higher than the maximum allowed ingress rate for that ingress rate limitation rule. 2. At the test station, measure the data rate at one DUT port that forwards these frames. 3. From the test station, send valid single-tagged frames to DUT port A. These frames shall be constructed such that one ingress rate limitation rule is expected to apply. The data rate shall be by at least 10% higher than the maximum allowed ingress rate for that ingress rate limitation rule. 4. At the test station, measure the data rate of the traffic sent in step 3 at one DUT port that forwards these frames. 5. Repeat steps 3-4 for every ingress rate limitation rule on every DUT port.

Pass Criteria	<p>2. The test station receives traffic with 100% line-rate.</p> <p>4. The test station receives the traffic sent in step 3 with a data rate according to the required corresponding ingress rate limitation rule.</p>
Reference	802.1Q-2018
Notes	Testability depends on the overall QoS and Policing configuration of the DUT. Certain constellations of combined QoS and Policing mechanisms might cause that the test is not entirely testable according to this specification, but possibly with an alternative test specifically tailored for the respective configuration; however, such an alternative approach would require deeper analysis of multiple configuration aspects and is therefore not within the scope of this test specification.

5.6.1.1.9 SWITCH_FILT_009: [Ingress_rate_limitation_double-tagged](#)

Synopsis	Check if ingress rate limitation is implemented as required using double-tagged frames.
Prerequisites	<p>Ingress rate limitation for specific frames is required on at least one DUT port.</p> <p>Double-tagged frames are accepted on at least one DUT port on which ingress rate limitation is required.</p>
Test setup	Standard test setup for switching
Test Input Parameters	<ul style="list-style-type: none"> • VLAN configuration • All required ingress rate limitation rules on every DUT port, including: <ul style="list-style-type: none"> ○ Filter definition for which the limitation applies ○ The maximum allowed ingress rate
Test Procedure	<ol style="list-style-type: none"> 1. From the test station, send valid double-tagged frames to a DUT port A that accepts untagged frames and on which ingress rate limitation is required. These frames shall be constructed such that no ingress rate limitation rule is expected to apply. The data rate shall be by at least 10% higher than the maximum allowed ingress rate for that ingress rate limitation rule. 2. At the test station, measure the data rate at one DUT port that forwards these frames. 3. From the test station, send valid double-tagged frames to a DUT port A that accepts untagged frames and on which ingress rate limitation is required. These frames shall be constructed such that one ingress rate limitation rule is expected to apply. The data rate shall be by at least 10% higher than the maximum allowed ingress rate for that ingress rate limitation rule. 4. At the test station, measure the data rate of the traffic sent in step 3 at one DUT port that forwards these frames. 5. Repeat steps 3-4 for every ingress rate limitation rule on every DUT port.
Pass Criteria	2. The test station receives traffic with 100% line-rate.

	4. The test station receives the traffic sent in step 3 with a data rate according to the required corresponding ingress rate limitation rule.
Reference	802.1Q-2018
Notes	Testability depends on the overall QoS and Policing configuration of the DUT. Certain constellations of combined QoS and Policing mechanisms might cause that the test is not entirely testable according to this specification, but possibly with an alternative test specifically tailored for the respective configuration; however, such an alternative approach would require deeper analysis of multiple configuration aspects and is therefore not within the scope of this test specification.

5.6.1.1.10 SWITCH_FILT_010: SWITCH_Policing_Information_external_ports

Synopsis	Check if the switch is able to provide status information regarding the configured ingress filters.
Prerequisites	Ingress rate limitation for specific frames is required on at least one DUT port. Double-tagged frames are accepted on at least one DUT port on which ingress rate limitation is required.
Test setup	Standard test setup for switching
Test Input Parameters	Customer's filtering and policing configuration requirements at external ports
Test Procedure	<ol style="list-style-type: none"> 1. From the test station to a DUT port A, send traffic that is expected to be filtered and/or policed at DUT port A according to one of the customer's filtering and policing requirements 2. Wait to check the capture how many of the frames sent in step 2 are not being forwarded 3. Read DUT counter indicating number of frames affected by the filtering and/or policing rules of port A 4. Repeat steps 1-3 for every external DUT port such that every port is tested with at least one ingress filtering and at least one policing rule, if such rules are expected at that port according to the customer's filtering/policing requirements.
Pass Criteria	3. The counter of ingress filtered and/or policed frames at port A are equal to the number of not forwarded frames obtained in step 3
Reference	n/a
Notes	n/a

5.6.1.1.11 SWITCH_FILT_011: SWITCH_Policing_Information_external_ports

Synopsys	Check if the switch is able to provide status information regarding the configured ingress filters.
Prerequisites	n/a
Test setup	Standard test setup for switching
Test Input Parameters	n/a
Test Procedure	<ol style="list-style-type: none"> 1. Enable traffic monitoring on all switch ports 2. Wait 60 seconds 3. Read DUT counters indicating a number of frames affected by the filtering rules of all internal ports
Pass Criteria	<p>3. The counters of ingress-filtered frames at internal ports are equal to 0 If a counter of ingress-filtered frames at any internal port is not 0, the test result shall be reported as “Warning” instead of “Fail”.</p>
Reference	n/a
Notes	<p>In general, traffic generated by an application behind internal ports might influence several counters, including the counter of frames affected by the filtering rules at an internal port’s ingress. An application is, however, not expected to send frames that are filtered already at the ingress, but it is not impossible, either.</p> <p>It is out of the scope of this test to do further investigations in case that a counter of filtered frames for any internal port has a non-zero value as – most likely – this would be an issue caused by the application itself which unnecessarily or unintentionally sends frames that will be filtered at ingress.</p> <p>This test is settled in the section “Filtering of incoming frames”, but not passing the Pass Criteria does not clearly indicate a failure of the filtering mechanism. Thus, in such a case, the test result shall be reported as “Warning” instead of “Fail”.</p>

5.7 Time synchronization

5.7.1.1.1 SWITCH_TIME_001: Time_Synchronization_timestamping

Synopsys	Check if the time information transmitted from time synchronization master ports is not distorted due to interfering traffic.
Prerequisites	The DUT has at least one time synchronization master port according to IEEE 1588 or IEEE 802.1AS/IEEE 802.1AS-Rev.
Test setup	Standard test setup for switching
Test Input Parameters	<ul style="list-style-type: none"> • VLAN configuration • Time domains • Type of time domains (IEEE 1588/IEEE 802.1AS/IEEE 802.1AS-Rev) • One-step clock and two-step clock ports per time domain • Time synchronization master ports in the bridged time domain • Additional time synchronization information if explicitly deviating from the underlying standard (e.g. VLAN tags for 802.1AS frames or destination MAC addresses for PTP frames different than 01:80:C2:00:00:0E).
Test Procedure	<ol style="list-style-type: none"> 1. At the test station, start time synchronization emulation by sending valid Sync and – if necessary – Follow_Up messages to every bridge slave port and by replying to delay measurement request messages correctly in the bridged time domain. 2. At the test station, start sending valid frames with an Ethernet payload size of 1500 bytes such that every time synchronization master port is expected to forward traffic with 80-90% line-rate. 3. Capture and ingress-timestamp every time synchronization traffic for at least 300 seconds. 4. At every DUT port, wait for 60 seconds and calculate the protocol times reconstructed from every one-step Sync message's and from every two-step Sync/Follow_Up message pair's timestamp fields received from the DUT. 5. For every Sync message, calculate the difference between the ingress timestamp captured in step 3 and the time reconstructed in step 4. 6. Check if the differences calculated in step 5 are all within +/- 200ns in one particular time domain. 7. Repeat step 6 for every time domain.
Pass Criteria	6. The calculated differences are all within +/- 200ns for the time domain.
Reference	<ul style="list-style-type: none"> • IEEE 1588-2008 • IEEE 802.1AS-2011 • IEEE P802.1AS-Rev/D8.0

Notes	<p>The tolerance of 200ns in step 6 allows four maximum timestamp quantization errors of 40ns each and additional minor errors in both the DUT, the time synchronization emulating device and the capturing device.</p> <p>This test only verifies that the time synchronization grandmaster port roles are assigned correctly and that the time synchronization is based on a one-step or two-step clock as required.</p> <p>For overall time synchronization compliance, additional protocol tests are necessary which goes beyond the scope of TC8 layer 2 switching section.</p>
-------	--

5.8 Quality of Service

5.8.1.1.1 SWITCH_QOS_001: Strict_Priority_Algorithm

Synopsis	Check if the switch is configured to use Strict Priority as transmission selection algorithm on particular ports.
Prerequisites	<p>Strict Priority is required as transmission selection algorithm on at least one DUT port.</p> <p>The DUT's QoS and policing configuration allows comparative testing with different VLAN priorities.</p> <p>DUT has at least three external ports.</p>
Test setup	Standard test setup for switching
Test Input Parameters	<ul style="list-style-type: none"> • VLAN configuration • Ports on which Strict Priority is required • Mapping of VLAN priorities to internal traffic classes and vice versa for the ingress/egress of every DUT port. • All rules for VLAN priority overwriting on every DUT port.
Test Procedure	<ol style="list-style-type: none"> 1. From the test station, start sending valid frames, tagged with a VLAN priority such that the frames are mapped to the highest traffic class with 100% line-rate to one DUT port A. The frames should be tagged and addressed such that they are expected to be forwarded to a DUT port C that shall use Strict Priority. 2. From the test station, start sending valid frames, tagged with a VLAN priority such that the frames are mapped to a lower traffic class than in step 1 with 100% line-rate to another DUT port B. The frames should also be tagged and addressed such that they are expected to be forwarded to DUT port C. 3. At DUT port C, check if the DUT forwards frames sent in steps 1 and 2. 4. Stop all traffic. 5. Repeat steps 1-4 for every DUT port that requires Strict Priority.
Pass Criteria	3. The test station receives all frames from port C that have been sent in step 1.

	3. The test station does not receive any frame from port C that has been sent in step 2.
Reference	IEEE 802.1Q-2018
Notes	<p>If the DUT generates frames tagged such that they are mapped to the highest traffic class, it is possible that not all frames from step 1 are forwarded.</p> <p>Testability depends on the overall QoS and Policing configuration of the DUT. Certain constellations of combined QoS and Policing mechanisms might cause that the test is not testable according to this specification, but possibly with an alternative test specifically tailored for the respective configuration; however, such an alternative approach would require deeper analysis of multiple configuration aspects and is therefore not within the scope of this test specification.</p>

5.8.1.1.2 SWITCH_QOS_002: Weighted_Round_Robin

Synopsis	Check if the switch is configured to use Weighted Round Robin (WRR) as transmission selection algorithm on particular ports.
Prerequisites	<p>WRR is required as transmission selection algorithm on at least one DUT port.</p> <p>The DUT's QoS and policing configuration allows comparative testing with different VLAN priorities.</p> <p>DUT has at least three external ports.</p>
Test setup	Standard test setup for switching
Test Input Parameters	<ul style="list-style-type: none"> • VLAN configuration • Ports on which WRR is required • Weights of each priority • Mapping of VLAN priorities to internal traffic classes and vice versa for the ingress/egress of every DUT port • All rules for VLAN priority overwriting on every DUT port
Test Procedure	<ol style="list-style-type: none"> 1. From the test station, start sending valid frames with a frame size s_1 of 750 bytes or less and tagged with a VLAN priority such that the frames are mapped to the highest, weighted traffic class with 100% line-rate to one DUT port A. The frames should be tagged and addressed such that they are expected to be forwarded to a DUT port C that shall use Weighted Round Robin. 2. From the test station, start sending valid frames with a frame size s_2 and tagged with a VLAN priority such that the frames are mapped to a lower, differently weighted traffic class than in step 1 with 100% line-rate to another DUT port B. The frames should also be tagged and addressed such that they are expected to be forwarded to DUT port C. The frame size s_2 shall be bigger than s_1 by the factor 2, i.e. $s_2 = 2*s_1$.

	<ol style="list-style-type: none"> 3. At DUT port C, start counting the numbers of frames forwarded sent from port A and from port B for a duration of at least 5 seconds. 4. Stop all traffic. 5. Repeat steps 1-4 for every DUT port that requires Weighted Round Robin.
Pass Criteria	3. The test station receives frames from port C with VLAN priorities in a numeric ratio that corresponds to the required weighting of the WRR, independently of the frame sizes.
Reference	n/a
Notes	Testability depends on the overall QoS and Policing configuration of the DUT. Certain constellations of combined QoS and Policing mechanisms might cause that the test is not testable according to this specification, but possibly with an alternative test specifically tailored for the respective configuration; however, such an alternative approach would require deeper analysis of multiple configuration aspects and is therefore not within the scope of this test specification.

5.8.1.1.3 SWITCH_QOS_003: Mapping_between_VLAN_Priority_and_Traffic_Class

Synopsys	Check if the mapping between VLAN priority and internal traffic class and vice versa is configured like required.
Prerequisites	<p>DUT has at least three external ports.</p> <p>Strict Priority is required as transmission selection algorithm on all external DUT port.</p>
Test setup	Standard test setup for switching
Test Input Parameters	<ul style="list-style-type: none"> • VLAN configuration • Mapping of VLAN priorities to internal traffic classes and vice versa for the ingress/egress of every DUT port • All rules for VLAN priority overwriting on every DUT port
Test Procedure	<ol style="list-style-type: none"> 1. From the test station, start sending valid frames, tagged with a VLAN priority such that the frames are mapped to one particular traffic class with 100% line-rate to one DUT port A. The frames should be tagged and addressed such that they are expected to be forwarded to at least one DUT port C. 2. From the test station, start sending valid frames, tagged with a VLAN priority such that the frames are mapped to one particular traffic class with 100% line-rate to one DUT port B. The frames should also be tagged and addressed such that they are expected to be forwarded to DUT port C. 3. At DUT port C, check if the DUT forwards frames sent in steps 1 and 2. 4. At DUT port C, check if the received frames carry the correct VLAN priority according to the VLAN priority to traffic class mapping, the traffic class to VLAN priority mapping and the priority overwriting rules. 5. Stop all traffic.

	<ol style="list-style-type: none"> 6. Repeat steps 1-5 for every combination of VLAN priorities in steps 1 and 2, and with untagged frames (i.e. using the default VLAN priority of the port). 7. Repeat steps 1-6 such that every DUT port has been used at least one time as port A, B and C.
Pass Criteria	<ol style="list-style-type: none"> 3. The test station does not receive any frames from DUT port C that are sent in step 1 or 2 and expected to be dropped due to the Strict Priority Algorithm. 3. The test station receives frames from DUT port C that are sent in step 1 or 2 and not expected to be dropped due to the Strict Priority Algorithm. 4. The received frames carry a VLAN priority that corresponds to the VLAN priority mapping and the priority overwriting rules.
Reference	IEEE 802.1Q-2018
Notes	Testability depends on the overall QoS and Policing configuration of the DUT. Certain constellations of combined QoS and Policing mechanisms might cause that the test is not entirely testable according to this specification, but possibly with an alternative test specifically tailored for the respective configuration; however, such an alternative approach would require deeper analysis of multiple configuration aspects and is therefore not within the scope of this test specification.

5.8.1.1.4 SWITCH_QOS_004: Rate-based_traffic_shaping

Synopsys	Check if the switch is configured correctly to use rate-based traffic shapers.
Prerequisites	n/a
Test setup	Standard test setup for switching
Test Input Parameters	<ul style="list-style-type: none"> • VLAN configuration • Mapping of VLAN priorities to internal traffic classes and vice versa for the ingress/egress of every DUT port • All rules for VLAN priority overwriting on every DUT port • Credit-based shaper idleSlope for every DUT port and traffic class • Egress leaky bucket shaper layer 1 forwarding rates for every DUT port and traffic class
Test Procedure	<ol style="list-style-type: none"> 1. From the test station, start sending valid frames with a frame size of 64 bytes with 100% line-rate to one DUT port A, tagged with a VLAN priority such that the frames are mapped to one particular traffic class. The frames should be tagged and addressed such that they are expected to be forwarded to at least one DUT port B. 2. At the test station, measure the forwarding rate in layer 1 bits per second at DUT port B for all frames sent in step 1. 3. At the test station, check if the received traffic contains bursts for the frames sent in step 1 over an observation duration of at least 5 seconds. 4. Repeat steps 1-2 for frames with an Ethernet payload size of 1500 bytes.

	<ol style="list-style-type: none"> 5. Repeat steps 1-3 for every VLAN priority in step 1 and with untagged frames (i.e. using the default VLAN priority of the port). 6. Repeat steps 1-4 such that every DUT port has been used at least one time as port B.
Pass Criteria	<ol style="list-style-type: none"> 2. The test station receives the frames sent in step 1 with a layer 1 bitrate that corresponds to the idleSlope of these frames' expected traffic class. 2. If the tested traffic class is not required to be shaped, the layer 1 bitrate is 100% line-rate. 3. If the tested traffic class is required to be shaped with a credit-based shaper, no bursts are observed.
Reference	IEEE 802.1Q-2018
Notes	<p>Step 4 mentions the Ethernet payload size instead of the frame size. This is because untagged frames will have an expected maximum frame size of 1518 bytes, while single-tagged frames can have up to 1522 bytes and double-tagged frames up to 1526 bytes.</p> <p>Testability depends on the overall QoS and Policing configuration of the DUT. Certain constellations of combined QoS and Policing mechanisms might cause that the test is not entirely testable according to this specification, but possibly with an alternative test specifically tailored for the respective configuration; however, such an alternative approach would require deeper analysis of multiple configuration aspects and is therefore not within the scope of this test specification.</p>

5.9 Configuration

5.9.1.1.1 SWITCH_CONF_001: Starting_in_Dont_Forward_Mode_tagged_invalid_ingress_VID

Synopsis	Check if DUT supports starting in „don't forward“ mode before switch configuration is completed, using tagged frames.
Prerequisites	n/a
Test setup	Standard test setup for switching
Test Input Parameters	VLAN configuration
Test Procedure	<ol style="list-style-type: none"> 1. Power off DUT. 2. From the test station, start sending broadcast frames with a size of 64 bytes to every DUT port; the frames shall carry a VID that is not allowed at any port. 3. Power on DUT.

	4. At the test station, check if any frame sent in step 2 is forwarded at any DUT port.
Pass Criteria	4. The test station does not receive any frame sent in step 2 from any DUT port.
Reference	n/a
Notes	n/a

5.9.1.1.2 SWITCH_CONF_002: Starting_in_Dont_Forward_Mode_tagged_invalid_egress_VID

Synopsys	Check if DUT supports starting in „don’t forward“ mode before switch configuration is completed, using tagged frames.
Prerequisites	At least one VID is expected to be forwarded to least one, but not every external port.
Test setup	Standard test setup for switching
Test Input Parameters	VLAN configuration
Test Procedure	<ol style="list-style-type: none"> 1. Power off DUT. 2. From the test station, start sending valid broadcast frames with a size of 64 bytes to every DUT port; the frames shall carry a VID that is expected to be forwarded to least one, but not every external port. 3. Power on DUT. 4. At the test station, check if any frame sent in step 2 is forwarded at any DUT port.
Pass Criteria	4. The test station does not receive any frame sent in step 2 from any DUT port on which the VID used in step 2 is not expected to be forwarded.
Reference	n/a
Notes	n/a

5.9.1.1.3 SWITCH_CONF_003: Starting_in_Dont_Forward_Mode_untagged

Synopsys	Check if DUT supports starting in „don’t forward“ mode before switch configuration is completed, using untagged frames.
Prerequisites	UT is not allowed to accept and forward untagged frames on at least one external port.
Test setup	Standard test setup for switching

Test Input Parameters	n/a
Test Procedure	<ol style="list-style-type: none"> 1. Power off DUT. 2. From the test station, start sending untagged broadcast frames with a size of 64 bytes to every DUT port that is not allowed to accept untagged frames. 3. Power on DUT. 4. At the test station, check if any frame sent in step 2 is forwarded at any DUT port.
Pass Criteria	<ol style="list-style-type: none"> 4. The test station does not receive any frame sent in step 2 from any DUT port.
Reference	n/a
Notes	n/a